

AIRFIELD LIGHTING SYSTEM

including Radio Controller
& AV70-RF Solar Aviation Lights
Installation & Service Manual

AV70-RF Solar Aviation Light

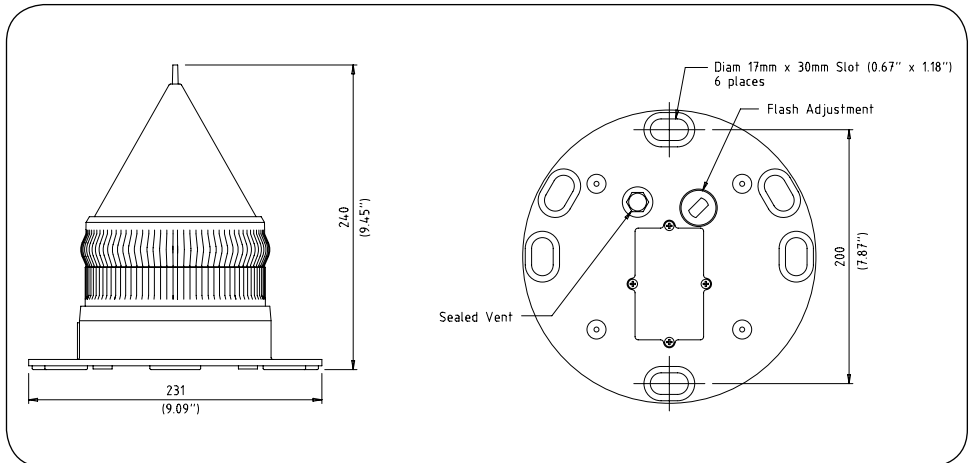
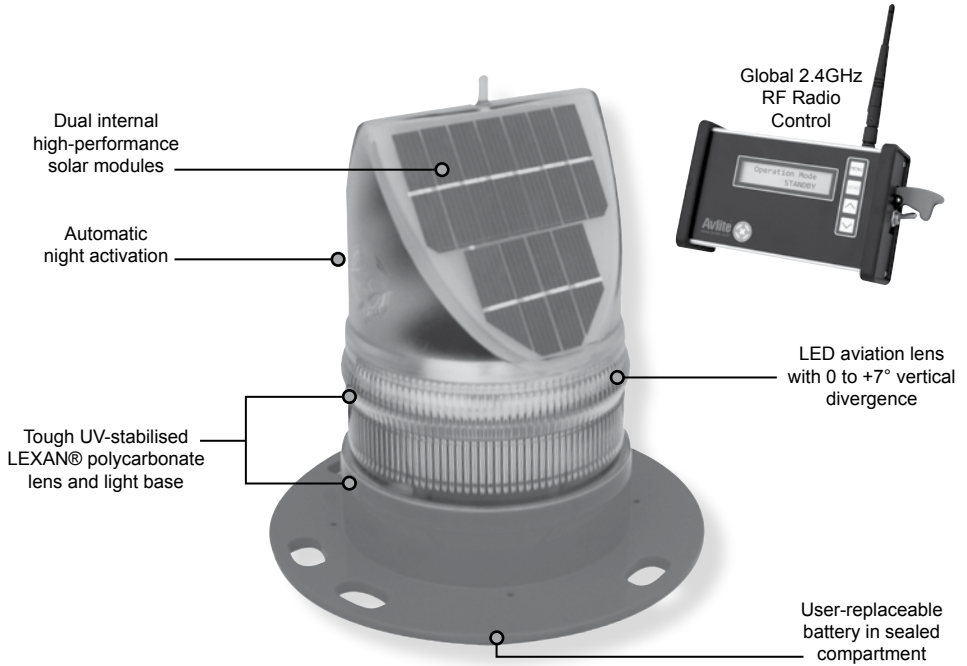

Figure 1 Leading Dimensions of AV70-RF

Table of Contents

Introduction	4
Operating Principle	4
Technology	4
AV70-RF Model	5
Optional Configurations	7
Assembly & Installation	8
Unpacking Instructions	8
Initial Inspection	8
Assembling the Light & Configuration of Settings	8
Installing the Light Assembly to the Frangible Stake Mount	9
Installing the Light Assembly to the Frangible Concrete Mount.....	10
How Does the System Work?	11
Standard Operating Procedure	11
Best Practice	11
Manual Light Activation via External Momentary Button (where fitted)	12
Avlite Radio Controller	13
Assembly & Installation of Radio Controller	14
Unpacking Instructions	14
Initial Inspection.....	14
Assembling & Charging.....	14
Turning the Unit On	14
Charging the Radio Controller.....	14
Radio Controller Menu	15
Modes of Operation	15
Light Group.....	15
LED Intensity	15
Timeout Mode.....	15
Timeout Duration	15
LED Bank Setup.....	16
Battery Diagnostic	16
Controller Battery Voltage.....	16
Sending Commands	16
Using the Radio Control to Activate the Airfield Lighting System (ALS)	17
Turn All the Lights ON	17
Setup the Lights to Operate in DUSK till DAWN Mode.	17
Runway B Only is to be HIGH Intensity, but Runway A will remain in Current Configuration.....	17
Runway B Only is to be HIGH Intensity, with a Timeout of 8 Minutes & Runway A will be I/R Low Intensity High Intensity.	17
Flash Codes	19
Maintenance & Servicing	24
Trouble Shooting	25
Avlite Light Warranty	26

Version No.	Description	Date	Approved
1.0	Manual Launch	July 2010	K. Paton
1.1	Trouble Shooting Update	December 2010	A. Burns
2.0	Update: Quality Logo	May 2011	P. Rainey
2.1	Update to mounting section	November 2011	M. Henry



Introduction

Congratulations! By choosing to purchase an Avlite light, you have become the owner of one of the most advanced solar LED airfield lights in the world.

Avlite Systems draws on more than 25 years experience in the design and manufacture of navigation aids, and particular care has been taken to ensure your light gives years of trouble free service.

As a commitment to producing the highest quality products for our customers, Avlite has been independently certified as complying with the requirements of ISO9001:2008 quality management system.

By taking a few moments to browse through this booklet, you will become familiar with the versatility of your light, and be able to maximise its operating function.

Please remember to complete the Avlite warranty registration card accompanying your light.

Operating Principle

The solar module of the light converts sunlight to an electrical current that is used to charge the battery. The battery provides power to operate the light at night.

The flasher unit has very low current requirements. A microprocessor drives an array of ultra bright LED's through a DC/DC converter, which enables the LED's to operate within the manufacturer's specifications. The battery is protected from over-charging within the circuit to ensure maximum battery life.

On darkness, the microprocessor will initiate a program check and after approximately 1 minute will turn on.

Technology

Avlite Systems is a world-class solar lighting systems manufacturer with a proven reputation for rapid, innovative, and agile technology solutions designed specifically for defense, government, civil and humanitarian aid operations in the most remote, toughest environments.

Electronics

Avlite employs leading in-house electronic engineers in the design and development of software and related circuitry. All individual electronic components are sourced directly by Avlite procurement staff ensuring that only the highest quality components are used in our products.

LED Technology

All aviation lights use the latest advancements in LED (Light Emitting Diode) technology as a light source. The major advantage of LED's over traditional light sources is well established in that they typically have an operational life in excess of 100,000 hours, resulting in substantial savings to maintenance and servicing costs.

Precision Construction

Commitment to investing in the design and construction of injection-moulded parts including optic lenses, light bases and a range of other components ensures that all Avlite products are of a consistent and superior quality.

Optical Performance

Avlite manufactures a range of aviation LED lenses moulded from multi-cavity dies. Complex shapes such as the AV70 and 16-segment multi-focus lenses are a testament to the company's superior in-house lens manufacturing capabilities and outstanding optical performance.

Award-winning, Patented Technology

Several United States and Australian patent registrations are held on Avlite's range of innovative designs, with other regional patents pending in Canada, United Kingdom and Europe.



AV70-RF Model

The AV70-RF solar aviation light is a radio controlled version of the popular AV70 which can be used in conjunction with a PALC or simple handheld controller. Users can wirelessly control ON/OFF functions, adjust light intensities, change colours or switch between visual and IR (tactical) operational modes.

The solar modules of the light convert sunlight to an electrical current that is used to charge the battery. The battery provides power to operate the light at night.

The LED driving circuitry has very low current requirements. A microprocessor drives an array of ultra bright LED's through a DC/DC converter, which enables the LED's to operate within the manufacturer's specifications. The battery is protected from over-charging within the circuit to ensure maximum battery life.

On darkness, the microprocessor will initiate a program check and after approximately 1 minute begin steady on operation.

The Avlite AV70-RF solar airfield light is exceptional in its unique ability to 'track the sun', operating reliably in low sunlight conditions. Made from tough, durable polycarbonate and using the latest high-intensity LED's, the AV70-RF light boasts dual high-performance solar modules incorporated into Avlite's world-first Solar Collection Lens.

The AV70-RF will automatically synchronize with other radio equipped lights within range. The control unit is not required for this synchronization. Lights with different light groups that contain the same flash code will synchronize. Lights with different LED banks that contain the same flash code will synchronize. Non-Radio Controlled Lights with a radio equipped will synchronize with radio controlled units. Lights with different flash codes will not synchronize.

Multiple Radio Controllers can be used to operate the lights at the same time.

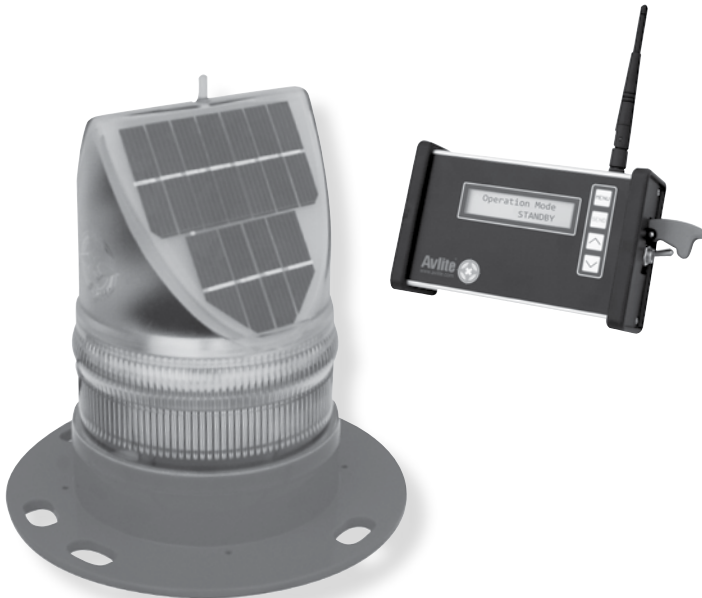

SPECIFICATIONS • AV70-RF

Light Characteristics

Light Source
Available colours
Peak Intensity (cd)†

Horizontal Output (degrees)
Vertical Divergence (degrees)
Reflector Type

Available Flash Characteristics
Intensity Adjustments
LED Life Expectancy (hours)

Electrical Characteristics

Operating Voltage (v)
Temperature Range

Solar Characteristics

Solar Module Type
Output (watts)
Solar Module Efficiency (%)
Charging Regulation

Power Supply

Battery Type
Battery Capacity (Ah)
Nominal Voltage (v)
Autonomy (nights)

Radio Control

Physical Characteristics

Body Material
Lens Material
Lens Diameter (mm/inches)
Lens Design
Mounting
Height (mm/inches)
Width (mm/inches)
Mass (kg/lbs)
Product Life Expectancy

Environmental Factors

Humidity
Icing
Wind Speed
Shock
Vibration

Certifications

CE
Quality Assurance
Waterproof

Intellectual Property

Patents
Trademarks

Warranty *

12 ultra-high intensity LEDs
Red, Green, White, Yellow, Amber, Blue, IR, Sectored Combinations
Steady-on: Blue - 2.8 Red - 6.8 Green - 9.0 White - 7.0 Yellow - 6.5
Flashing: Blue - 5.5 Red - 18.2 Green - 21.9 White - 19.1 Yellow - 15.1
360
0 to +7
Omnidirectional 360° LED Reflector
(US Pat. No. 6,667,582. AU Pat. No. 778,918)
256 including steady-on, controlled by radio
Adjustable in 25% increments
>100,000

3.6
-40 to 80°C

Multicrystalline
2.5 (2 x 1.25watt)
14
Microprocessor controlled

High grade NiMH – Environmentally friendly
8
3.6
Steady-on: >14
Flashing: >38 (14 hour darkness, 12.5% duty cycle)
For specifications see following table

LEXAN® Polycarbonate – UV stabilized
LEXAN® Polycarbonate – UV stabilized
140 / 5½
External optics with interior flute design
6 x 17mm holes on 200mm PCD
240 / 9½
231 / 9⅞
1.1 / 2⅜
Up to 12 years

0 to 100%, MIL-STD-810F
22kg per square inch
Up to 160kph
MIL-STD-202G, Test Condition G, Method 213B
MIL-STD202G, Test Condition B, Method 204

EN61000-6-3:1997, EN61000-6-1:1997
ISO9001:2008
IP68

US Pat. No. 6,667,582. AU Pat. No. 778,918
AVLITE® is a registered trademark of Avlite Systems
Full 3 year warranty

• Specifications subject to change or variation without notice
• Subject to standard terms and conditions
† Intensity setting subject to solar availability



SPECIFICATIONS • Radio Control

Electrical Characteristics

Range
Temperature Range
Frequency (GHz)
Nominal Voltage (V dc)

1.5km, peer-to-peer networking
-40 to 80°C
2.4
7.2

Power Supply

Battery Type
Battery Capacity (Ah)
Nominal Voltage (V dc)

High grade NiMH – Environmentally friendly
16
7.2

Physical Characteristics

Case Material
Screen
Product Life Expectancy

Anodised aluminium
Backlit
Up to 12 years

Certifications

FCC Approved
CE
Quality Assurance

M100103
EN61000-6-3:1997, EN61000-6-1:1997
ISO9001:2008

Intellectual Property

Trademarks

AVLITE® is a registered trademark of Avlite Systems

Warranty *

1 year



Handheld controller and charger in protective case

- Specifications subject to change or variation without notice
- Subject to standard terms and conditions



Optional Configurations

Optional External ON/OFF Switch

The AV70-RF can be fitted with an external ON/OFF switch below the solar panel at the base of the unit. The ON/OFF switch may be useful if the unit is only required for short periods and is often being moved or needs to be stored often, and disconnecting the battery is not viable.

External Battery Charging Port

The AV70-RF can be fitted with an external DC charging port. The external charging port can be used to charge the battery while the light is stored for extended periods, ensuring the battery is fully charged when the light is ready for use.

Optional Manual Operation

An external momentary button can be incorporated into the AV70-RF for emergency use. If the radio controller is lost or damaged this button allows users to turn the light on manually and step through the different intensity levels.

Avlite Pilot Activated Lighting Control

The Avlite wireless network of the AV70-RF can be integrated to a third party Pilot Activated Lighting Controller (AV-PALC), to allow approaching aircraft to activate lighting on unmanned aerodromes.



Assembly & Installation

The installation of the AV70-RF Solar Airfield Light includes the following steps:-

- Unpacking
- Initial Inspection
- Assembling the light & configuration of settings
- Installing the light assembly

Tools required for assembly & installation:-

- Large flat blade screwdriver (to suit "Flash Adjustment" Plug)
- Hammer or Sledge Hammer
- 6mm Allen Key

Unpacking Instructions

Unpack all hardware and verify container contents in accordance with Fig. 2 or Fig. 3. Please contact your Avlite office if there is any hardware missing.

Initial Inspection

Inspect all hardware for damage. If there is any damage, please contact your Avlite Office. Retain original packing material for possible future use in shipping the AV70-RF.

Assembling the Light & Configuration of Settings



- 1. Before activating the lights, the lights must be layed out on the runway in the location they will be installed.**
- 2. RF lights should always be installed on mounting plates and stakes. Avlite does not recommend installation on rubber tiles.**

- a. Use a large flat-blade screwdriver to remove the Flash Adjustment Plug from the base of the light (see Figure 1).
A sealed vent on the base allows air transfer without moisture intake and should not be disturbed.
- b. Setting the Light Group: Adjust Rotary Switches, A & B.
Determine, to which group, each individual light belongs. E.g., taxiway edge lights = 0, runway edge lights = 1, obstruction lights = 2, threshold lights = 3, etc...
Adjust Rotary Switch A to the appropriate light group. E.g. 0, 1, or 2
- c. Set the toggle switch to the "ON" position. This will activate the AV70-RF.
- d. To test operation of the light, the Radio Controller will need to be used (see "Using the Radio Control to activate the ALS System" section of manual for information).
- e. Replace the Flash Adjustment Plug.
- f. Bolt the light into location.

Installing the Light Assembly to the Frangible Stake Mount



1. Before activating the lights, the lights must be layed out on the runway in the location they will be installed.
2. RF lights should always be installed on mounting plates and stakes. Avlite does not recommend installation on rubber tiles.

The completed AV70-RF mount plate assembly is to be mounted on the Stake (Fig 3) in firm soil (not loose sand, screenings or other unbound material).

- a. Fit the AV70-RF light on the top of the mounting plate. Insert bolts through the four holes in the mount, entering from the bottom. Install a penny washer and a Nylock nut on each bolt and tighten.
- b. Fit the boss of the mount plate into the shorter barrel of the frangible sleeve. Using a 6mm Allen key, tighten the socket head cap screw against the stake mount boss.
- c. Use a sledge hammer to drive the stake into the soil at the chosen location. Drive the stake down until the bottom of the stake sleeve is at ground level.
During Installation every effort should be made to ensure that the light is level when installation is complete. When installing a stake mount into the ground ensure that the stake is installed straight into the ground and not on an angle. Ensure that the mounting plate is level using a spirit level.
- d. Fit the AV70-RF mount plate assembly on top of the stake. The longer barrel of the Frangible Sleeve should completely cover the stake sleeve. Using a 6mm Allen key, tighten the bottom socket head cap screw against the stake sleeve.

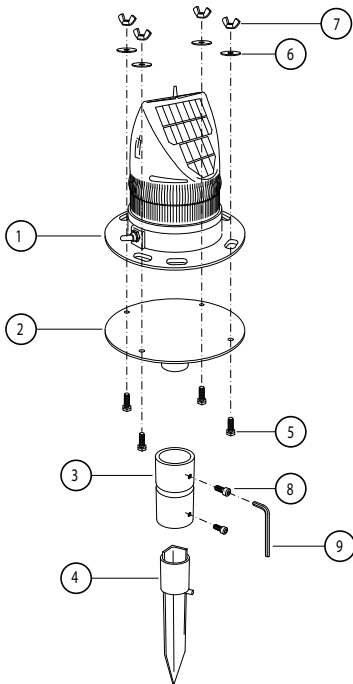

Item	Description	Qty
1	AV70-RF Solar Airfield Light	1
2	Mount Plate	1
3	Frangible Sleeve	1
4	Stake (355mm)	1
5	Bolt, 8mm x 30	4
6	Penny Washer, 8mm	4
7	Nylock Nut, 8mm	4
8	Socket Head Cap Screw, 8mm x 16	2
9	Allen Key, 6mm	1

Figure 3 Frangible Stake Mount Installation

Installing the Light Assembly to the Frangible Concrete Mount



1. Before activating the lights, the lights must be layed out on the runway in the location they will be installed.
2. RF lights should always be installed on mounting plates and stakes. Avlite does not recommend installation on rubber tiles.

- a. Mount the base plate to the concrete using 4 x M8 concrete bolts.
- b. Fit the frangible mounting plate onto the concrete base plate and secure using the M8 x 16 SHCS
- c. During Installation every effort should be made to ensure that the light is level when installation is complete.

The following guide lines will help to ensure that the lights will be installed correctly.

- When installing a concrete mount plate ensure that the concrete pad is level using a spirit level.

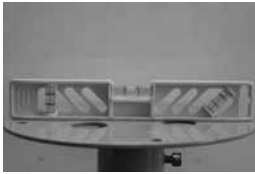

Check the mounting plate with a spirit level in all directions

- d. Fit the AV70-RF to the light mounting plate using M8 SHCS, large flat washers and Nylock nuts.

Note: After adjustments, ensure all nuts and bolts are tightened securely and all tools, spares and packaging are removed from the runway.

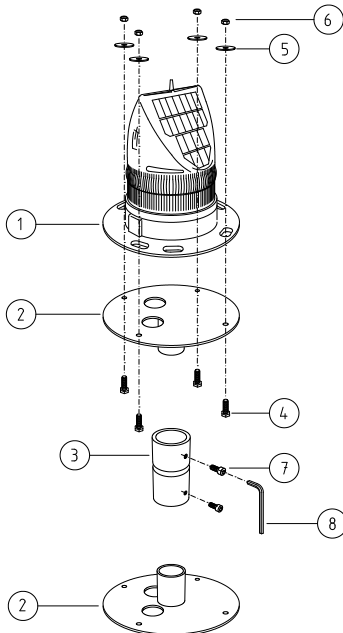

Item	Description	Qty
1	AV70-RF Solar Airfiled Light	1
2	Mount Plate	2
3	Frangible Sleeve	1
4	Bolt, 8mm x 25	4
5	Penny Washer, 8mm	4
6	Nylock Nut, 8mm	4
7	Socket Head Cap Screw, 8mm x 16	2
8	Allen Key, 6mm	1

Figure 4 Frangible Concrete Mount Installation



How Does the System Work?

The Avlite ALS System works by using a hand held radio controller to activate and setup an entire airfield, airport or air base. The system utilises an embedded R/F module operating in the 2.4Ghz ISM Band.

The lights can be configured for up to 15 different light groups. This allows the airfield to independently control different areas, such as multiple runways, taxiways and helipads.

Due to the handheld nature of the Radio Controller, it can be used from any position in the airfield. This can allow for easy and efficient inspection or activation of different light groups in the airfield without affecting other lights.

The standard radio controller broadcasts a command message to all lights within range. This range is approximately 1.4km (0.9 miles). If a higher gain antenna is used the range can be extended. Each light within range will receive, decode and re-send the message to all surrounding lights. Each light also has an operational range of 1.4km.

For distances, greater than 1.4km there may be a delay in those lights receiving the command. The further away the lights are from the controller the longer it will take the command to propagate to all lights.

Standard Operating Procedure

To get the most from your ALS please use the following setup

1. Set the "Operation Mode" to DUSK till DAWN.
2. Set the "LED Intensity" Setting to LOW
3. Set the "Light Light Sensor" to Enable

This will allow you lights automatically turn on when at night and turn off during the day. The lights are completely autonomous in this state and will not require daily control.

If you need to increase the intensity see "LED Intensity" section of this manual.

Best Practice

It is best to locate the controller centrally about the runway when sending commands to achieve the minimum response time.

If the controller is situated at one end of a 3.2km (12 000') runway, it will take longer to activate all lights than from a central position.

The battery inside the light will require extra charge time the following day if the lights are run at HIGH intensity for more than the recommended time. This can be negated by connecting the lights to an external power supply.

If these lights are plugged into an external power supply they can be run at any intensity for any length of time without depleting the battery.



Manual Light Activation via External Momentary Button (where fitted to AV70-RF)

The AV70-RF lights are available with optional external momentary button for manual light operation. The momentary button may be incorporated in the AV70-RF for emergency use or in case the radio controller is lost or damaged. This button enables the user to manually turn the light on and step through the three different intensity levels.

To activate the AV70-RF using the momentary button:-

- a. Hold down the push button for 3 seconds. (The light will activate in LOW intensity mode)
- b. Press the momentary button again it will adjust to MEDIUM intensity mode
- c. Press the momentary button a third time to achieve HIGH intensity mode
- d. Pressing the momentary button again will return the intensity to LOW.

When the light is activated from the momentary button, it will change its operation mode to “Dusk till Dawn”. This will mean that the light will turn on when the ambient lighting conditions become dark, and will turn off when it detects daylight.

Notes:

- If the light is activated via the momentary button during daylight hours, it will stay on for 30 seconds before the photo sensor on the circuit board automatically turns the light off.
- When the controller is found or repaired, the lights will revert back to radio control as soon as they receive a new message/command from the radio controller.

PLEASE NOTE!

- The lights will automatically reduce intensity to low after the TIMEOUT limit is reached. The timeout is set via the radio controller.
- If the TIMEOUT Mode is disabled in the radio controller the lights will stay at the manually set intensity until daylight switches the light off.

Avlite Radio Controller

The Avlite Radio Controller is a compact handheld unit that allows complete control of the airfield lighting system. The unit allows you to roam around the airfield for easy activation, inspection and testing of the airfield lights. The Avlite Radio Controller works on the 2.4GHz ISM Band using a low power RF module. The backlit, LCD can be seen during day or night. The straightforward menu makes the ALS easy to operate.

The Avlite Radio Controller comes standard with an IP68 rated charging plug, omni-directional antenna and ON/OFF switch and cover. It can also be optioned with an RS232 input or PC interface.

The Radio Controller and charger come in an IP68 'Pelican' Case to protect it from the harsh environment to which it may be subjected.

The Avlite Radio Controller can be rack mounted in a standard 19" rack for use with other airfield electronic equipment such as PALC.

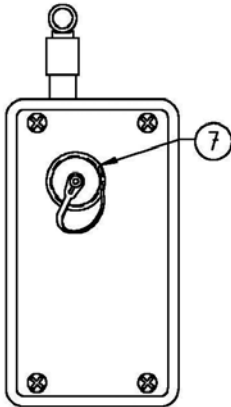

Fig 4 Radio Controller Side View

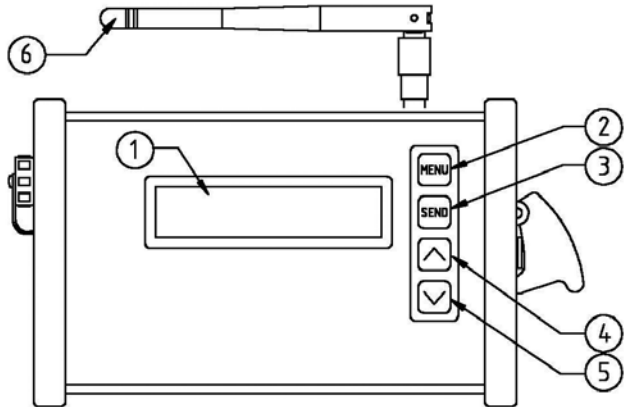

Fig 5 Radio Controller Front View

- 1 LCD Screen
- 2 MENU Button
- 3 SEND Button
- 4 UP Button
- 5 DOWN Button
- 6 6" Di pole Omni Directional, Right Angle Whip Antenna
- 7 Charging Port – IP68 sealed plug. (Charger not shown)
- 8 RS232 input. (Optional)



Assembly & Installation of Radio Controller

The installation of the Radio Controller includes the following steps:-

- Unpacking
- Initial Inspection
- Assembling & Charging the Radio Controller
- Using the Radio Controller

Unpacking instructions

Unpack all hardware and verify container contents in accordance with Fig. 4 & 5. Please contact your Avlite office if there is any hardware missing.

Initial inspection

Inspect the Radio Controller for damage. If there is any damage, please contact your Avlite office. Retain original packing material for possible future use.

Assembly & Charging

The Radio Controller can be activated after raising the aerial into the upright position, see Fig 5.

It may be necessary to charge the Radio Controller before use.

Turning the Unit On

To turn the unit on, lift the red missile cover and flick the switch.

The radio controller will take 5 seconds to start up and it may take up to 30 seconds for the imbedded RF Module to be configured, before a command can be sent.

Charging the Radio Controller

- a. Unscrew the protective cap from the charging port, on the left side of the Radio Controller.
- b. Insert the charging terminal into the Radio Controller.
- c. Plug the charger into a wall socket and turn the charger on.
- d. The light on the charger will flash Green, Orange, Red then back to Orange.
- e. The charger has a LED to indicate the charge sequence.
 - i. Green – Unit is fully charged. The Radio Controller can be left connected in state.
 - ii. Orange – Unit is charging. The unit will charge for a maximum of 8 hours before automatically shutting down.
 - iii. Red – A fault is occurring, please contact Avlite Office.

Radio Controller Menu

This section of the document will provide a short explanation of all the menu screens on the control unit.

Modes of Operation

The operational Mode defines how the light will respond to different environmental conditions & user inputs. There are three operational modes that can be selected via the controller. *ON, STANDBY & DUSK till DAWN.*

ON Operational Mode

The light is *Always On*. The light will be lit both day & night. While the light is in this mode it will only turn off when the battery drops below the Flat Battery Voltage level. (AV70-RF = 3.1V)

STANDBY Operational Mode

The light is *Always Off*. While the light is in this mode it will still respond to and pass on commands, sent by the controller. This mode should be used if the lights have been installed outside but are not currently required.

Note: The light is not completely powered down in a manner suitable for storage. If the light is to be stored in a warehouse or other dark environment the ON/OFF switch should be turned off.

DUSK till DAWN Operational Mode

The light is turned on and off based on the two sensor inputs. These sensors include a light sensor internal to each light and an external input line on the control unit. Each of these sensors can be enabled and disabled independently. If all of the sensors are disabled the light will be off. If the internal sensor is enabled and the light is in the darkness, it will turn on.

Pilot Activation Operational Mode

The light can be activated if the radio controller is connected to a PALC system.

Light Group

This menu is used to select the current light group. The light group of each light is selected via rotary switch A found on the bottom of the circuit board, in the Light Head. The controller can select any one of the 15 individual light groups

(0 -> 9, A -> E) or select all radio lights at once.

Note: *The units are set with a light group of 0 in the factory.*

LED Intensity

Default = LOW

This menu is used to select the intensity of the LEDs on the light. The options include *Low, Medium & High.*

- a. Low – LED intensity is set to low setting (approx 12.5%)
- b. Medium - LED intensity is set to medium intensity (approx 40%).
- c. High - LED intensity is set to high intensity (approx 100%)

Note: this menu will not be enabled if the selected operational mode is *STANDBY*

Timeout Mode

This menu is used to setup the LED high intensity timeout feature found in each light. The options include *Enabled LOW, Disable.*

- a. Enabled LOW – The immediate LED intensity is selected via the LED Intensity menu, after Timer Duration the LED Intensity will revert back to the LOW setting
- b. Disable – The high intensity LED timeout is disabled. The LED intensity will be selected via the LED intensity menu.

Note: this menu will not be enabled if the selected operational mode is *STANDBY*

Timeout Duration

This menu is only visible when the timeout Mode is enabled. This menu is used to select the timeout duration, the time before the LED intensity reverts back to its LOW intensity state. The timeout duration can be set from 1 minute to 60 minutes.

LED Bank Setup

All Avlite ALS systems can have the option of having the lights built with multiple colours, in different LED banks. This can allow a runway to be changed from Visible to I/R at the press of a button.

The options include *VISIBLE & IR*.

Note: this menu will not be enabled if the selected operational mode is *STANDBY*

Battery Diagnostic

Default = Disable

This feature can be used to check the battery voltage in every light in the ALS. The command can be sent any time and it will not affect the current state of the light. If the light is in *STANDBY* mode the light will turn on as shown below and revert to *STANDBY* mode after the diagnostic has been completed.

- If the battery voltage is within operational range the light will turn off for 1 second, flash once, then turn off for 1 second.
- If the battery voltage is low the light will turn off for 1 second, flash twice, then turn off for 1 second.

Diagnostic Pass

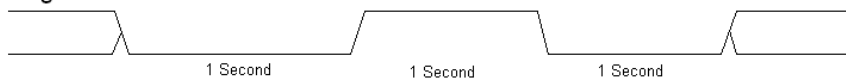

Diagnostic Fail

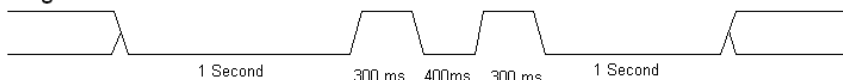

Controller Battery Voltage

This menu displays the current battery voltage of the controller unit.

Any voltage above 7.2V is within operational range.

If the voltage is below 7V the controller should be charged immediately. See “Charging the Radio Controller” section.

The Radio Controller can be left, permanently plugged into the charger, if required.

Note: *The Radio Controller can still be used while it is charging.*

Sending Commands

Every time the SEND button is pressed a command is sent containing all the current settings in the Radio Controller.

The SEND button can be used after changing one setting or after changing multiple settings.

For further information see section under “How does the System Work”.

Using the Radio Control to Activate the Airfield Lighting System (ALS)

The Radio Controller is very easy to use and by reading through the How To section below, all of the advanced features will be well within your grasp.

Make sure that all the lights in the same Light Group have had the rotary switches set correctly, see "Assembling the Light" section for details.

Turn All the Lights ON

- Turn the Radio Controller On
- Use the arrow keys to adjust the operational Mode to *ON*
- Press *MENU* button once to reach *Light Group*
- Set the Light Group to ALL
- Press *SEND* button
- Every radio light within range of the control unit will now turn on.

Setup the Lights to Operate in DUSK till DAWN mode

- Turn the Control unit On
- Use the arrow keys to adjust the operational Mode to *DUSK till DAWN*
- Press *MENU* button once to reach *Light Group*
- Set the Light Group to ALL
- Press *MENU* button until you reach *Light Light Sensor*
- Use the arrow keys to adjust the Light Light Sensor to *Enable*
- Press *SEND* button
- Every radio light within range of the control unit will now turn on at night, during the day the lights will turn off automatically.

Runway B Only is to be HIGH Intensity, but Runway A will Remain in Current Configuration

- On Runway A, set the rotary switches to A=0 B=0 inside the light head.
- On Runway B, set the rotary switches to A=1 B=0 inside the light head. *Rotary Switch A can be set to any value that is different from Runway A.*
- Turn the Control unit On
- Use the arrow keys to adjust the operational Mode to *On*
- Press *MENU* button once to reach *Light Group*
- Set the Light Group to 1
- Press *MENU* button once to reach *LED Intensity*
- Use the arrow keys to adjust the LED Intensity to *HIGH*
- Press *MENU* button until you reach *LED Bank Setup*
- Use the arrow keys to adjust the LED Bank to *Visible*
- Press *SEND* button
 - *Runway A will not change state.*
 - *Runway B will now be High Intensity.*



Runway B Only is to be HIGH Intensity, with a Timeout of 8 Minutes and Runway A will be I/R Low Intensity

- On Runway A, set the rotary switches to A=0 B=0 inside the light head.
- On Runway B, set the rotary switches to A=1 B=0 inside the light head. *Rotary Switch A can be set to any value that is different from Runway A.*
- Turn the Control unit On
- Use the arrow keys to adjust the operational Mode to *On*
- Press *MENU* button once to reach *Light Group*
- Set the Light Group to 1
- Press *MENU* button once to reach *LED Intensity*
- Use the arrow keys to adjust the LED Intensity to *HIGH*
- Press *MENU* button once to reach *Timeout Mode*
- Use the arrow keys to adjust the Timeout Mode to Enabled *LOW*
- Press *MENU* button once to reach *Timeout Duration*
- Use the arrow keys to adjust the Timeout Duration to *8 Minutes*
- Press *MENU* button once to reach *LED Bank Setup*
- Use the arrow keys to adjust the LED Bank to *Visible*
- Press *SEND* button
 - *Runway A will not change state.*
 - *Runway B will now be High Intensity. After 8 minute Runway will revert back to LOW intensity.*
- Press *MENU* button until you reach *Light Group*
- Set the Light Group to 0
- Press *MENU* button once to reach *LED Intensity*
- Use the arrow keys to adjust the LED Intensity to *LOW*
- Press *MENU* button until you reach *LED Bank Setup*
- Use the arrow keys to adjust the LED Bank to *IR*
- Press *SEND* button
 - *Runway A will be in LOW Intensity IR mode*
 - *Runway B will not change state. Lights on Runway B will still receive and pass on the message intended for Runway A.*



Flash Codes

All AV70-RF lights are programmed to be Steady On. Alternatively they are able to be programmed to flash in any of the 250 different flash codes, if the option is activated.

All lights controlled by the Radio Controller can be set to any flash code. All AV70-RF lights set to the same flash pattern will automatically flash in synchronisation. Lights may be set up into "light groups" and then allocated the required flash setting per light group as required.

For example, VQ (6) + LFL 10 S means 6 very quick flashes followed by a long flash, during a 10-second interval.

The amount of power your light draws through the night depends on the duty cycle, i.e. the amount of time on as a proportion to the timing cycle. For example, 0.5 seconds on and 4.5 seconds off equals a 10% duty cycle. It is best to operate at the lowest duty cycle appropriate to the actual needs of the application.

AVLITE® code reference is listed by number of flashes

**For the latest version of this document visit www.avlite.com,
or email support@avlite.com**

Symbols

FL	Flash followed by number Eg. FL 1 S, one flash every second
F	Fixed
Q	Quick flash
VQ	Very quick flash
OC	Occulting; greater period on than off
ISO	Isophase; equal period on and off
LFL	Long flash long
MO	Morse code () contains letter

SWITCH	FLASH CODE	ON	OFF
A	B		
0	0 F (Steady light)		
D	3 VQ 0.5 S	0.2	0.3
E	3 VQ 0.6 S	0.2	0.4
F	3 VQ 0.6 S	0.3	0.3
7	3 Q 1 S	0.2	0.8
8	3 Q 1 S	0.3	0.7
9	3 Q 1 S	0.4	0.6
A	3 Q 1 S	0.5	0.5
8	4 Q 1 S	0.8	0.2
B	3 Q 1.2 S	0.3	0.9
9	4 Q 1.2 S	0.5	0.7
C	3 Q 1.2 S	0.6	0.6
F	4 FL 1.5 S	0.2	1.3
1	0 FL 1.5 S	0.3	1.2
0	5 FL 1.5 S	0.4	1.1
0	4 FL 1.5 S	0.5	1.0
2	0 FL 2 S	0.2	1.8
3	0 FL 2 S	0.3	1.7
4	0 FL 2 S	0.4	1.6
5	0 FL 2 S	0.5	1.5
6	0 FL 2 S	0.7	1.3
7	0 FL 2 S	0.8	1.2
1	2 ISO 2 S	1.0	1.0
8	0 FL 2.5 S	0.3	2.2
9	0 FL 2.5 S	0.5	2.0
D	6 FL 2.5 S	1.0	1.5
1	5 FL 3 S	0.2	2.8
A	0 FL 3 S	0.3	2.7
2	5 FL 3 S	0.4	2.6
B	0 FL 3 S	0.5	2.5
3	5 FL 3 S	0.6	2.4
C	0 FL 3 S	0.7	2.3
D	0 FL 3 S	1.0	2.0
2	2 ISO 3 S	1.5	1.5
5	4 OC 3 S	2.0	1.0
E	2 OC 3 S	2.5	0.5
4	6 OC 3.5 S	2.5	1.0
4	5 FL 4 S	0.2	3.8
5	5 FL 4 S	0.3	3.7
E	0 FL 4 S	0.4	3.6
F	0 FL 4 S	0.5	3.5
6	5 FL 4 S	0.6	3.4
0	1 FL 4 S	0.8	3.2
1	1 FL 4 S	1.0	3.0
2	1 FL 4 S	1.5	2.5
3	2 ISO 4 S	2.0	2.0
3	6 OC 4 S	2.5	1.5
F	2 OC 4 S	3.0	1.0
3	1 FL 4.3 S	1.3	3.0
8	5 FL 5 S	0.2	4.8
4	1 FL 5 S	0.3	4.7
5	1 FL 5 S	0.5	4.5
9	5 FL 5 S	0.9	4.1
6	1 FL 5 S	1.0	4.0

SWITCH	FLASH CODE	ON	OFF
A	B		
7	1 FL 5 S	1.5	3.5
4	2 ISO 5 S	2.5	2.5
8	2 LFL 5 S	2.0	3.0
0	3 OC 5 S	3.0	2.0
1	3 OC 5 S	4.0	1.0
2	3 OC 5 S	4.5	0.5
C	6 FL 6 S	0.2	5.8
B	5 FL 6 S	0.3	5.7
C	5 FL 6 S	0.4	5.6
8	1 FL 6 S	0.5	5.5
9	1 FL 6 S	0.6	5.4
A	1 FL 6 S	1.0	5.0
7	5 FL 6 S	1.2	4.8
B	1 FL 6 S	1.5	4.5
5	2 ISO 6 S	3.0	3.0
9	2 LFL 6 S	2.0	4.0
6	4 OC 6 S	4.0	2.0
3	3 OC 6 S	4.5	1.5
4	3 OC 6 S	5.0	1.0
A	4 FL 7 S	1.0	6.0
9	6 FL 7 S	2.0	5.0
5	6 OC 7 S	4.5	2.5
D	5 FL 7.5 S	0.5	7.0
C	1 FL 7.5 S	0.8	6.7
E	5 FL 8 S	0.5	7.5
B	4 FL 8 S	1.0	7.0
6	2 ISO 8 S	4.0	4.0
A	2 LFL 8 S	2.0	6.0
6	6 OC 8 S	5.0	3.0
B	2 LFL 8 S	3.0	5.0
F	5 FL 9 S	0.9	8.1
C	4 FL 9 S	1.0	8.0
7	6 OC 9 S	6.0	3.0
0	6 FL 10 S	0.2	9.8
1	6 FL 10 S	0.3	9.7
D	1 FL 10 S	0.5	9.5
2	6 FL 10 S	0.8	9.2
E	1 FL 10 S	1.0	9.0
1	4 FL 10 S	1.5	8.5
C	2 LFL 10 S	2.0	8.0
D	2 LFL 10 S	3.0	7.0
7	2 ISO 10 S	5.0	5.0
2	4 LFL 10 S	4.0	6.0
8	6 OC 10 S	6.0	4.0
5	3 OC 10 S	7.0	3.0
6	3 OC 10 S	7.5	2.5
F	1 FL 12 S	1.2	10.8
D	4 FL 12 S	2.5	9.5
3	4 LFL 12 S	2.0	10.0
0	2 FL 15 S	1.0	14.0
4	4 LFL 15 S	4.0	11.0
7	4 OC 15 S	10	5.0
A	6 LFL 20 S	2.0	18.0
E	4 FL 26 S	1.0	25.0

SWITCH	FLASH CODE	ON	OFF	ON	OFF
A	B				
0	A FL (2) 4 S	0.5	1.0	0.5	2.0
E	B VQ (2) 4 S	0.2	1.0	0.2	2.6
1	A FL (2) 4.5 S	0.3	1.0	0.3	2.9
2	A FL (2) 4.5 S	0.4	1.0	0.4	2.7
3	A FL (2) 4.5 S	0.5	1.0	0.5	2.5
F	9 FL (2) 5 S	0.2	0.8	0.2	3.8
2	C FL (2) 5 S	0.2	1.2	0.2	3.4
4	A FL (2) 5 S	0.4	0.6	0.4	3.6
0	7 FL (2) 5 S	0.5	1.0	0.5	3.0
1	7 FL (2) 5 S	1.0	1.0	1.0	2.0
9	B Q (2) 5 S	0.3	0.7	0.3	3.7
2	9 Q (2) 5 S	0.5	0.5	0.5	3.5
5	A FL (2) 5.5 S	0.4	1.4	0.4	3.3
7	8 FL (2) 6 S	0.3	0.6	1.0	4.1
A	A FL (2) 6 S	0.3	0.9	0.3	4.5
6	A FL (2) 6 S	0.3	1.0	0.3	4.4
7	A FL (2) 6 S	0.4	1.0	0.4	4.2
9	9 FL (2) 6 S	0.5	1.0	0.5	4.0
2	8 FL (2) 6 S	0.8	1.2	0.8	3.2
3	7 FL (2) 6 S	1.0	1.0	1.0	3.0
3	9 Q (2) 6 S	0.3	0.7	0.3	4.7
A	9 FL (2) 7 S	1.0	1.0	1.0	4.0
7	B FL (2) 8 S	0.4	0.6	2.0	5.0
8	A FL (2) 8 S	0.4	1.0	0.4	6.2
4	7 FL (2) 8 S	0.5	1.0	0.5	6.0
8	8 FL (2) 8 S	0.8	1.2	2.4	3.6
5	7 FL (2) 8 S	1.0	1.0	1.0	5.0
4	C OC (2) 8 S	3.0	2.0	1.0	2.0
5	C OC (2) 8 S	5.0	1.0	1.0	1.0
F	B VQ (2) 8 S	0.2	1.0	0.2	6.6
9	A FL (2) 10 S	0.4	1.6	0.4	7.6
6	7 FL (2) 10 S	0.5	1.0	0.5	8.0
7	7 FL (2) 10 S	0.5	1.5	0.5	7.5
6	9 FL (2) 10 S	0.5	2.0	0.5	7.0
8	7 FL (2) 10 S	0.8	1.2	0.8	7.2
B	9 FL (2) 10 S	1.0	1.0	1.0	7.0
9	7 FL (2) 10 S	1.0	1.5	1.0	6.5
4	9 Q (2) 10 S	0.6	0.4	0.6	8.4
B	A FL (2) 12 S	0.4	1.0	0.4	10.2
C	9 FL (2) 12 S	0.5	1.0	0.5	10.0
D	9 FL (2) 12 S	1.5	2.0	1.5	7.0
A	8 FL (2) 15 S	0.5	1.5	2.0	11.0
A	7 FL (2) 15 S	1.0	2.0	1.0	11.0
8	B Q (2) 15 S	0.2	0.8	0.2	13.8
C	A FL (2) 20 S	1.0	3.0	1.0	15.0
D	A FL (2) 25 S	1.0	1.0	1.0	22.0

SWITCH	FLASH CODE	ON	OFF	ON	OFF	ON	OFF
A	B						
7	9 Q (3) 5 S	0.5	0.5	0.5	0.5	0.5	2.5
5	9 VQ (3) 5 S	0.2	0.3	0.2	0.3	0.2	3.8
0	C VQ (3) 5 S	0.3	0.2	0.3	0.2	0.3	3.7
E	9 VQ (3) 5 S	0.3	0.3	0.3	0.3	0.3	3.5
3	C FL (3) 6 S	0.5	1.0	0.5	1.0	0.5	2.5
2	B FL (2+1) 6 S	0.3	0.4	0.3	1.2	0.3	3.5

SWITCH	FLASH CODE	ON	OFF	ON	OFF	ON	OFF	
A	B							
A	B	Q (3) 6 S	0.3	0.7	0.3	0.7	0.3	3.7
F	A	FL (3) 8 S	0.5	1.0	0.5	1.0	0.5	4.5
0	B	FL (3) 9 S	0.3	1.0	0.3	1.0	0.3	6.1
B	7	FL (3) 9 S	0.8	1.2	0.8	1.2	0.8	4.2
B	8	FL (3) 10 S	0.3	0.7	0.3	0.7	0.9	7.1
C	8	FL (3) 10 S	0.4	0.6	0.4	0.6	1.2	6.8
C	B	FL (3) 10 S	0.5	0.5	0.5	0.5	0.5	7.5
C	7	FL (3) 10 S	0.5	1.5	0.5	1.5	0.5	5.5
D	B	FL (3) 10 S	0.6	0.6	0.6	0.6	0.6	7.0
D	7	FL (3) 10 S	1.0	1.0	1.0	1.0	1.0	5.0
3	8	FL (2+1) 10 S	0.5	0.7	0.5	2.1	0.5	5.7
8	9	OC (3) 10 S	5.0	1.0	1.0	1.0	1.0	1.0
B	B	Q (3) 10 S	0.3	0.7	0.3	0.7	0.3	7.7
D	8	FL (2 + 1) 10 S	0.5	0.5	0.5	0.5	1.5	6.5
1	B	FL (3) 12 S	0.5	1.5	0.5	1.5	0.5	7.5
E	A	FL (3) 12 S	0.5	2.0	0.5	2.0	0.5	6.5
E	7	FL (3) 12 S	0.8	1.2	0.8	1.2	0.8	7.2
B	6	FL (3) 12 S	1.0	1.0	1.0	3.0	1.0	5.0
4	8	FL (2+1) 12 S	0.8	1.2	0.8	2.4	0.8	6.0
5	8	FL (2+1) 12 S	1.0	1.0	1.0	4.0	1.0	4.0
1	8	FL (2+1) 13.5 S	1.0	1.0	1.0	4.0	1.0	5.5
F	7	FL (3) 15 S	0.3	1.7	0.3	1.7	0.3	10.7
9	D	FL (3) 15 S	0.4	1.0	0.4	1.0	0.4	11.8
0	8	FL (3) 15 S	0.5	1.5	0.5	1.5	0.5	10.5
F	8	FL (2+1) 15 S	0.6	0.3	0.6	0.3	1.4	11.8
0	9	FL (2+1) 15 S	0.7	0.5	0.7	0.5	1.9	10.7
1	9	FL (2+1) 15 S	0.7	0.7	0.7	0.7	2.1	10.1
6	8	FL (2+1) 15 S	1.0	2.0	1.0	5.0	1.0	5.0
1	C	VQ (3) 15 S	0.1	0.5	0.1	0.5	0.1	13.7
4	B	FL (3) 20 S	0.5	3.0	0.5	3.0	0.5	12.5
3	B	FL (3) 20 S	0.5	1.5	0.5	1.5	0.5	15.5
5	B	FL (3) 20 S	0.8	1.2	0.8	1.2	0.8	15.2
6	B	FL (3) 20 S	1.0	1.0	1.0	1.0	1.0	15.0

SWITCH	FLASH CODE	ON	OFF	ON	OFF	ON	OFF	ON	OFF
A	B								
B	F	VQ (4) 4 S	0.3	0.3	0.3	0.3	0.3	0.3	2.3
B	D	Q (4) 6 S	0.3	0.7	0.3	0.7	0.3	0.7	2.7
8	D	Q (4) 6 S	0.4	0.6	0.4	0.6	0.4	0.6	2.6
1	D	FL (4) 10 S	0.5	1.0	0.5	1.0	0.5	1.0	5.0
2	D	FL (4) 10 S	0.8	1.2	0.8	1.2	0.8	1.2	3.2
F	E	Q (4) 10 S	0.3	0.7	0.3	0.7	0.3	0.7	6.7
B	E	FL (4) 12 S	0.3	1.7	0.3	1.7	0.3	1.7	5.7
4	F	FL (4) 12 S	0.5	0.5	0.5	0.5	0.5	0.5	8.5
C	E	FL (4) 12 S	0.5	1.5	0.5	1.5	0.5	1.5	5.5
3	D	FL (4) 12 S	0.8	1.2	0.8	1.2	0.8	1.2	5.2
A	D	Q (4) 12 S	0.3	0.7	0.3	0.7	0.3	0.7	8.7
4	D	FL (4) 15 S	0.5	1.5	0.5	1.5	0.5	1.5	8.5
8	E	FL (4) 15 S	1.0	1.0	1.0	1.0	1.0	1.0	8.0
7	D	FL (4) 15 S	1.5	0.5	0.5	0.5	0.5	0.5	10.5
D	E	FL (4) 16 S	0.5	1.5	0.5	1.5	0.5	1.5	9.5
C	D	FL (4) 20 S	0.3	3.0	0.3	3.0	0.3	3.0	9.8
5	D	FL (4) 20 S	0.5	1.5	0.5	1.5	0.5	1.5	13.5
0	D	FL (4) 20 S	0.5	1.5	0.5	1.5	0.5	4.5	10.5
3	F	FL (4) 20 S	1.5	1.5	1.5	1.5	1.5	1.5	9.5
0	F	Q (4) 20 S	0.5	0.5	0.5	0.5	0.5	0.5	16.5
E	E	Q (4) 28 S	0.5	0.5	0.5	0.5	0.5	0.5	24.5
6	F	FL (4) 30 S	0.5	0.5	0.5	0.5	0.5	0.5	26.5

SWITCH	FLASH CODE	ON	OFF	ON	OFF	ON	OFF	ON	OFF	ON	OFF	
A	B											
D	D	Q (5) 7 S	0.3	0.7	0.3	0.7	0.3	0.7	0.3	0.7	0.3	2.7
E	D	Q (5) 10 S	0.3	0.7	0.3	0.7	0.3	0.7	0.3	0.7	0.3	5.7
E	8	FL (5) 12 S	0.5	1.5	0.5	1.5	0.5	1.5	0.5	1.5	0.5	3.5
5	F	FL (5) 20 S	0.5	0.5	0.5	0.5	0.5	0.5	0.5	0.5	0.5	15.5
9	F	FL (5) 20 S	0.8	1.2	0.8	1.2	0.8	1.2	0.8	1.2	0.8	11.2
9	E	FL (5) 20 S	1.0	1.0	1.0	1.0	1.0	1.0	1.0	1.0	1.0	11.0

SWITCH	FLASH CODE	ON	OFF	ON	OFF	ON	OFF	ON	OFF	ON	OFF	ON	OFF
A	B												
F	D	Q (6) 10 S	0.3	0.7	0.3	0.7	0.3	0.7	0.3	0.7	0.3	0.7	4.7
A	F	FL (6) 15 S	0.3	0.7	0.3	0.7	0.3	0.7	0.3	0.7	0.3	0.7	9.7
7	F	FL (6) 15 S	0.5	1.0	0.5	1.0	0.5	1.0	0.5	1.0	0.5	1.0	7.0
A	E	FL (6) + LFL 15 S	0.5	1.0	0.5	1.0	0.5	1.0	0.5	1.0	0.5	1.0	7.0

SWITCH	FLASH CODE	ON	OFF	ON	OFF	ON	OFF	ON	OFF	ON	OFF	ON	OFF	ON	OFF	
A	B															
6	E	VQ (6) + LFL 10 S	0.2	0.3	0.2	0.3	0.2	0.3	0.2	0.3	0.2	0.3	0.2	0.3	2.0	5.0
7	E	VQ (6) + LFL 10 S	0.3	0.3	0.3	0.3	0.3	0.3	0.3	0.3	0.3	0.3	0.3	0.3	2.0	4.4
2	F	Q (6) + LFL 15 S	0.2	0.8	0.2	0.8	0.2	0.8	0.2	0.8	0.2	0.8	0.2	0.8	2.0	7.0
2	E	Q (6) + LFL 15 S	0.3	0.7	0.3	0.7	0.3	0.7	0.3	0.7	0.3	0.7	0.3	0.7	2.0	7.0
3	E	Q (6) + LFL 15 S	0.6	0.6	0.6	0.6	0.6	0.6	0.6	0.6	0.6	0.6	0.6	0.6	2.0	5.8
8	F	VQ (6) + LFL 15 S	0.3	0.3	0.3	0.3	0.3	0.3	0.3	0.3	0.3	0.3	0.3	0.3	2.0	9.4

SWITCH	FLASH CODE	ON	OFF	ON	OFF	ON	OFF	ON	OFF	ON	OFF	ON	OFF	ON	OFF	ON	OFF	
A	B																	
4	E	VQ (9) 10 S	0.2	0.3	0.2	0.3	0.2	0.3	0.2	0.3	0.2	0.3	0.2	0.3	0.2	0.3	0.2	5.8
5	E	VQ (9) 10 S	0.3	0.3	0.3	0.3	0.3	0.3	0.3	0.3	0.3	0.3	0.3	0.3	0.3	0.3	0.3	4.9
1	F	Q (9) 15 S	0.2	0.8	0.2	0.8	0.2	0.8	0.2	0.8	0.2	0.8	0.2	0.8	0.2	0.8	0.2	6.8
0	E	Q (9) 15 S	0.3	0.7	0.3	0.7	0.3	0.7	0.3	0.7	0.3	0.7	0.3	0.7	0.3	0.7	0.3	6.7
1	E	Q (9) 15 S	0.6	0.6	0.6	0.6	0.6	0.6	0.6	0.6	0.6	0.6	0.6	0.6	0.6	0.6	0.6	4.8

SWITCH	FLASH CODE	ON	OFF	ON	OFF	ON	OFF	ON	OFF
A	B								
MORSE CODE () INDICATES LETTER									
7	8	MO (A) 6 S	0.3	0.6	1.0	4.1			
7	B	MO (A) 8 S	0.4	0.6	2.0	5.0			
8	8	MO (A) 8 S	0.8	1.2	2.4	3.6			
B	8	MO (U) 10 S	0.3	0.7	0.3	0.7	0.9	7.1	
C	8	MO (U) 10 S	0.4	0.6	0.4	0.6	1.2	6.8	
D	8	MO (U) 10 S	0.5	0.5	0.5	0.5	1.5	6.5	
9	8	MO (A) 10 S	0.5	0.5	1.5	7.5			
8	9	MO (D) 10 S	5.0	1.0	1.0	1.0	1.0	1.0	
A	8	MO (A) 15 S	0.5	1.5	2.0	11.0			
F	8	MO (U) 15 S	0.6	0.3	0.6	0.3	1.4	11.8	
0	9	MO (U) 15 S	0.7	0.5	0.7	0.5	1.9	10.7	
1	9	MO (U) 15 S	0.7	0.7	0.7	0.7	2.1	10.1	
7	D	MO (B) 15 S	1.5	0.5	0.5	0.5	0.5	0.5	10.5



Maintenance and Servicing

Designed to be maintenance free the AV70-RF light requires minimal attention, though the following maintenance and servicing information is provided to help ensure the life of your Avlite product.

General Maintenance

- a. **Cleaning Solar Panels-** Occasional cleaning of the solar panels may be required. Using a cloth and warm soapy water, wipe off any foreign matter before rinsing the panels with fresh water.
- b. **Battery Check-** Inspection of batteries should be performed annually to ensure that the charger, battery and ancillary electronics are functioning correctly. Using a voltage meter, check that the correct battery voltage is at least 3.6 volts under 100mA load for the AV70-RF and ensure all terminals are clear of foreign matter.

Replacing the Battery in AV70-RF

The AV70-RF light is the only compact airfield light with a double sealed battery compartment. This provides the user with the ability to change the battery after years of operation.

- a. Remove the light from either the Rubber Tile or Frangible Stake Mount.
- b. Turn light upside down and remove the Flash Adjustment Plug. Turn light 'OFF' via the internal switch.
- c. Unscrew 4 screws to remove battery plate.
- d. Remove battery from AV70-RF case and unscrew positive and negative leads.
- e. Discard old battery in a safe manner.
- f. Reattach positive and negative leads to new battery and then place back into case.
- g. Reattach battery plate and switch light 'ON' via internal switch. Replace the Flash Adjustment Plug.
- h. To test operation of the light, the remote control will need to be used (see "Using the Radio Control to activate the ALS System" section of manual for information).

Care must be taken to observe the polarity of the battery before the leads are re-connected, and ensure the replacement battery is correctly fitted. Always recycle old batteries.

AV70-RF Long Term Battery Storage

If the AV70-RF are to be placed in storage for an extended period please follow the below information.

- The NiMH batteries inside the AV70-RF must always be stored in a fully charged state.
- Disconnect the positive (+) and negative (-) wires from the battery before placing the light in storage.
- All batteries will discharge over time and the rate of discharge is dependent on temperature.
- If the light is being stored in temperatures greater than 30DegC the battery will discharge faster.
- Please check battery every 2-4 months and recharge if necessary,

Recharging the Battery

Reconnect the battery and place unit in the sun for 2-4 days

Or

Place the light in front of a halogen lamp for 2-3 days (*do not place the halogen light too close to the solar panel or the panel may be overheated*)

Trouble Shooting

Problem	Remedy
Light will not activate.	<ul style="list-style-type: none"> • Ensure internal toggle switch in the AV70-RF is set to the “ON” position • Wait at least 60 seconds for the program to initialise in darkness if the light is set for DUSK till DAWN Mode • Ensure battery is properly connected • Ensure battery voltage is sufficient
Light will not operate for the entire night.	<ul style="list-style-type: none"> • Expose light to direct sunlight and monitor operation for several days. Avlite products typically require 1.5 to 4 hours of direct sunlight per day to retain full autonomy. From a discharged state, the light may require several days of operational conditions to ‘cycle’ up to full autonomy • Reducing the light output intensity will reduce current draw on the battery • Ensure solar module is clean and not covered by shading, fouling or dust during the day
Lights are constantly on during the day.	<ul style="list-style-type: none"> • Ensure the Radio Controller is not set to ON (see “Modes of Operation” section of manual) & change the setting as required
<i>Radio Controller will not turn on.</i>	<ul style="list-style-type: none"> • Recharge the battery. The unit can be left attached to the charger for a constant battery charge.

All AV70-RF lights are fitted with Status Indicator LEDs. These may help determine operational status of the light depending on the flash rate of the Status Indicator LEDs.

LED Combinations		Light Status	Light	Comment
YELLOW LED	RED LED			
OFF	OFF	Normal	OFF	Normal running condition in daylight.
Flashing ON 0.1 seconds OFF 0.1 seconds	OFF	Normal	ON	Normal running condition, the Light LED's will also be ON.
	Fixed-on	Flat Battery (<3.2v)	OFF	Battery is flat. Battery must receive charge (above 3.5v) and light must see daylight for at least 1 minute before operation.
	Flashing ON 0.1 seconds OFF 0.1 seconds		ON	Battery is low. Battery must receive charge (above 3.5v) for at least 1 minute.
Fixed-on	OFF		ON	Battery is charged.
Flashing ON 1 second OFF 0.2 seconds	Flashing ON 1 second OFF 0.2 seconds		ON	Light's in factory setup mode (0xFF). Please change the Rotary Switches away from F, F to another setting, i.e. 0, 0

Status Indicator LED's do not appear while the light is in IR Mode.



Avlite Light Warranty V1.1

Activating the Warranty

Upon purchase, the Avlite Systems warranty must be activated for recognition of future claims. To do this you have two (2) options:

1. **Postal Registration**

Please complete the Avlite Systems Warranty Registration Card and return to Avlite within 30 days of your purchase.

2. **Online Registration**

Please complete the Online Registration Form at; www.avlite.com

Avlite Systems will repair or replace your lantern in the event of electronic failure for a period of up to three years from the date of purchase.

The unit must be returned to Avlite freight prepaid.

Warranty Terms

1. Avlite Systems warrants that any Avlite aviation products fitted with telemetry equipment including but not limited to AIS, GSM, GPS or RF ("Telemetry Products") will be free from defective materials and workmanship under normal and intended use, subject to the conditions hereinafter set forth, for a period of twelve (12) months from the date of purchase by the original purchaser.
2. Avlite Systems warrants that any rotationally-moulded products ("Roto-Moulded Products") and accessory products ("Accessory Products") will be free from defective materials and workmanship under normal and intended use, subject to the conditions hereinafter set forth, for a period of twelve (12) months from the date of purchase by the original purchaser.
3. Avlite Systems warrants that any Avlite aviation products other than the Telemetry Products, Roto-Moulded Products and Accessory Products ("Avlite Products") will be free from defective materials and workmanship under normal and intended use, subject to the conditions hereinafter set forth, for a period of three (3) years from the date of purchase by the original purchaser.
4. Avlite Systems will repair or replace, at Avlite's sole discretion, any Telemetry Products, Roto-Moulded Products, Accessory Products or Avlite Products found to be defective in material and workmanship in the relevant warranty period so long as the Warranty Conditions (set out below) are satisfied.
5. If any Telemetry Products or Avlite Products are fitted with a rechargeable battery, Avlite Systems warrants the battery will be free from defect for a period of one (1) year when used within original manufacturer's specifications and instructions.

Warranty Conditions

This Warranty is subject to the following conditions and limitations;

1. The warranty is applicable to lanterns manufactured from 1/1/2009.
2. The warranty is void and inapplicable if:
 - a. the product has been used or handled other than in accordance with the instructions in the owner's manual and any other information or instructions provided to the customer by Avlite;
 - b. the product has been deliberately abused, or misused, damaged by accident or neglect or in being transported; or
 - c. the defect is due to the product being repaired or tampered with by anyone other than Avlite or authorised Avlite repair personnel.
3. The customer must give Avlite Systems notice of any defect with the product within 30 days of the customer becoming aware of the defect.
4. Rechargeable batteries have a limited number of charge cycles and may eventually need to be replaced. Typical battery replacement period is 3-4 years. Long term exposure to high temperatures will shorten the battery life. Batteries used or stored in a manner inconsistent with the manufacturer's specifications and instructions shall not be covered by this warranty.



5. No modifications to the original specifications determined by Avlite shall be made without written approval of Avlite Systems.
6. Avlite lights can be fitted with 3rd party power supplies and accessories but are covered by the 3rd party warranty terms and conditions.
7. The product must be packed and returned to Avlite Systems by the customer at his or her sole expense. Avlite Systems will pay return freight of its choice. A returned product must be accompanied by a written description of the defect and a photocopy of the original purchase receipt. This receipt must clearly list model and serial number, the date of purchase, the name and address of the purchaser and authorised dealer and the price paid by the purchaser. On receipt of the product, Avlite Systems will assess the product and advise the customer as to whether the claimed defect is covered by this warranty.
8. Avlite Systems reserves the right to modify the design of any product without obligation to purchasers of previously manufactured products and to change the prices or specifications of any product without notice or obligation to any person.
9. Input voltage shall not exceed those recommended for the product.
10. Warranty does not cover damage caused by the incorrect replacement of battery in solar lantern models.
11. This warranty does not cover any damage or defect caused to any product as a result of water flooding or any other acts of nature.
12. There are no representations or warranties of any kind by Avlite or any other person who is an agent, employee, or other representative or affiliate of Avlite, express or implied, with respect to condition of performance of any product, their merchantability, or fitness for a particular purpose, or with respect to any other matter relating to any products.

Limitation of Liability

To the extent permitted by section 68A of the Trade Practices Act 1974 (Cth), the liability of Avlite Systems under this Warranty will be, at the option of Avlite Systems, limited to either the replacement or repair of any defective product covered by this Warranty. Avlite Systems will not be liable to Buyer for consequential damages resulting from any defect or deficiencies in accepted items.

Limited to Original Purchaser

This Warranty is for the sole benefit of the original purchaser of the covered product and shall not extend to any subsequent purchaser of the product.

Miscellaneous

Apart from the specific warranties provided under this warranty, all other express or implied warranties relating to the above product is hereby excluded to the fullest extent allowable under law. The warranty does not extend to any lost profits, loss of good will or any indirect, incidental or consequential costs or damages or losses incurred by the purchaser as a result of any defect with the covered product.

Warrantor

Avlite Systems has authorised distribution in many countries of the world. In each country, the authorised importing distributor has accepted the responsibility for warranty of products sold by distributor. Warranty service should normally be obtained from the importing distributor from whom you purchased your product. In the event of service required beyond the capability of the importer, Avlite Systems will fulfil the conditions of the warranty. Such product must be returned at the owner's expense to the Avlite Systems factory, together with a photocopy of the bill of sale for that product, a detailed description of the problem, and any information necessary for return shipment.

Other Avlite Products Available



Solar Aviation Lighting



**Radio Controlled &
PALC Systems (FCC Compliant)**



**Obstruction Lighting
(LIOL A & LIOL B)**



**Airfield Markers
& Accessories**

Typical Applications

- Temporary & permanent airfield lighting
- Remote, emergency & defence airfield lighting
- Barricade, hazard & perimeter lighting
- Obstruction Lighting

For a complete list of product compliances including ICAO & FAA, please contact Avlite today



Area & Sign Lighting



Head Office

Avlite Systems
11 Industrial Drive
Somerville, Vic 3912
Australia

Tel: +61 (0)3 5977 6128
Fax: +61 (0)3 5977 6124

Email: info@avlite.com
Internet: www.avlite.com

A subsidiary of Sealite Pty Ltd www.sealite.com