



AV-OL-ILAB-UM-R-D

& AV-OL-FL810-UM-R-D

**Universal AC Low Intensity Obstruction Light
Dual Fixture
Installation & Service Manual**



Version No.	Description	Date	Approved
1.0	Manual launch	Feb 2013	S. Turner
1.1	Fail Over Wiring Diagram	June 2015	W. Evans
1.2	Fail Over Wiring Diagram	July 2015	W. Evans
1.3	Spec Sheet Update	December 2016	W. Evans
1.4	Product Improvement	June 2018	C. Bernardo

Table of Contents

Introduction	Page 4
Technology	Page 4
AV-OL-ILAB-UM-R-D & AV-OL-ILAB-UM-R-D Models	Page 5
Safety Information	Page 9
Unpacking, Mounting, Installation, Wiring & Setup	Page 9
Unpacking.....	Page 9
Mounting.....	Page 9
Installation & Wiring.....	Page 9
Opening & Closing the Light Head	Page 10
AV Power.....	Page 10
Operation & Setup	Page 13
Intensity & Operation Mode Setting.....	Page 14
Alarm Relay Output.....	Page 15
RS232 & RS422/485 Communications (Optional) ..	Page 15
Optional GSM Monitoring & Control System	Page 17
Maintenance & Servicing	Page 18
Trouble Shooting	Page 19
Appendix	Page 20
Wiring Diagram	Page 20
Light Head Parts Diagram	Page 21
Main Enclosure Parts Diagram.....	Page 22
Product Order Codes.....	Page 23
Certifications & Compliance.....	Page 24
Avlite Light Warranty	Page 25



Introduction

Congratulations! By choosing to purchase an Avlite light, you have become the owner of one of the most advanced solar LED obstruction lights in the world.

Avlite Systems draws on more than 25 years experience in the design and manufacture of navigation aids, and particular care has been taken to ensure your light gives years of trouble free service.

As a commitment to producing the highest quality products for our customers, Avlite has been independently certified as complying with the requirements of ISO 9001:2015 quality management system.

By taking a few moments to browse through this booklet, you will become familiar with the versatility of your light, and be able to maximise its operating function.

Please remember to complete the Avlite warranty registration card accompanying your light.

Technology

Avlite Systems is a world-class solar lighting systems manufacturer with a proven reputation for rapid, innovative, and agile technology solutions designed specifically for defense, government, civil and humanitarian aid operations in the most remote, toughest environments.

Electronics

Avlite employs leading in-house electronic engineers in the design and development of software and related circuitry. All individual electronic components are sourced directly by Avlite procurement staff ensuring that only the highest quality components are used in our products.

LED Technology

All Avlite lights use the latest advancements in LED (Light Emitting Diode) technology as a light source. The major advantage of LED's over traditional light sources is well established in that they typically have an operational life in excess of 100,000 hours, resulting in substantial savings to maintenance and servicing costs.

Precision Construction

Commitment to investing in the design and construction of injection-moulded parts including optic lenses, light bases and a range of other components ensures that all Avlite products are of a consistent and superior quality.

Optical Performance

Avlite manufactures a range of aviation LED lenses moulded from multi-cavity dies. The company has superior in-house lens manufacturing capabilities to support outstanding optical performance.

Award-winning, Patented Technology

Several United States and Australian patent registrations are held on Avlite's range of innovative designs, with other regional patents pending in Canada, United Kingdom and Europe.

AV-OL-ILAB-UM-R-D & AV-OL-FL810-UM-R-D Models

This Avlite dual light fixture is a steady burning, low intensity LED obstruction light designed to comply with FAA L-810 and ICAO LIOL Type A & B requirements. The model can be used for marking obstacles up to 45 metres above ground, such as telecommunication towers, wind turbines, buildings and other tall structures.

Avlite's LED obstruction lights offer an ultra bright, energy efficient and cost effective lighting solution.

The dual light fixture can be configured to different operational states. Both light fixtures may be set to operate steady-burning. Alternatively, the dual light fixture may consist of a main light and a standby light. If the main light should ever fail the standby light will automatically switch on to ensure the obstacle is always clearly marked.

The light fixture incorporates internal diagnostic checking and an alarm contact for remote monitoring. The alarm relay is energised in normal operation and is released whenever the LED is not lit.



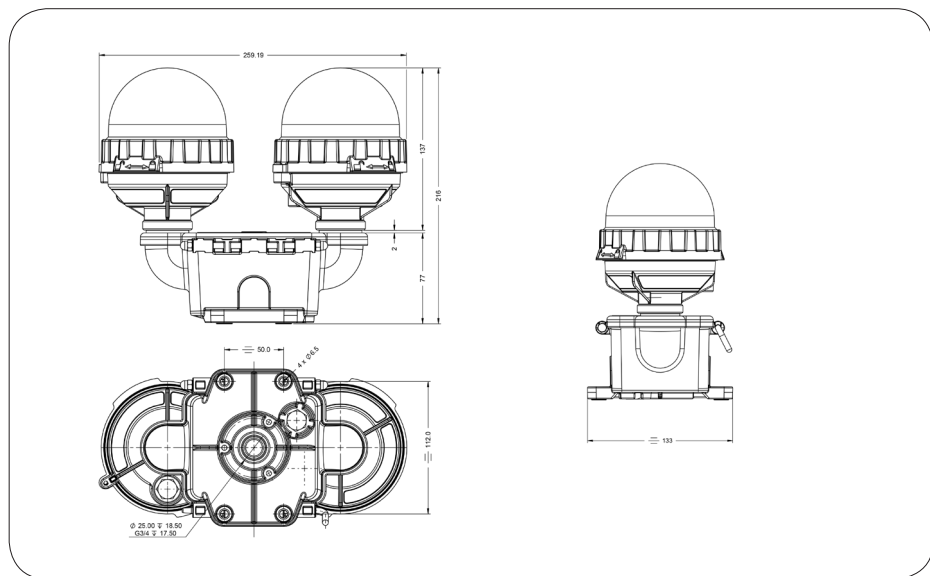
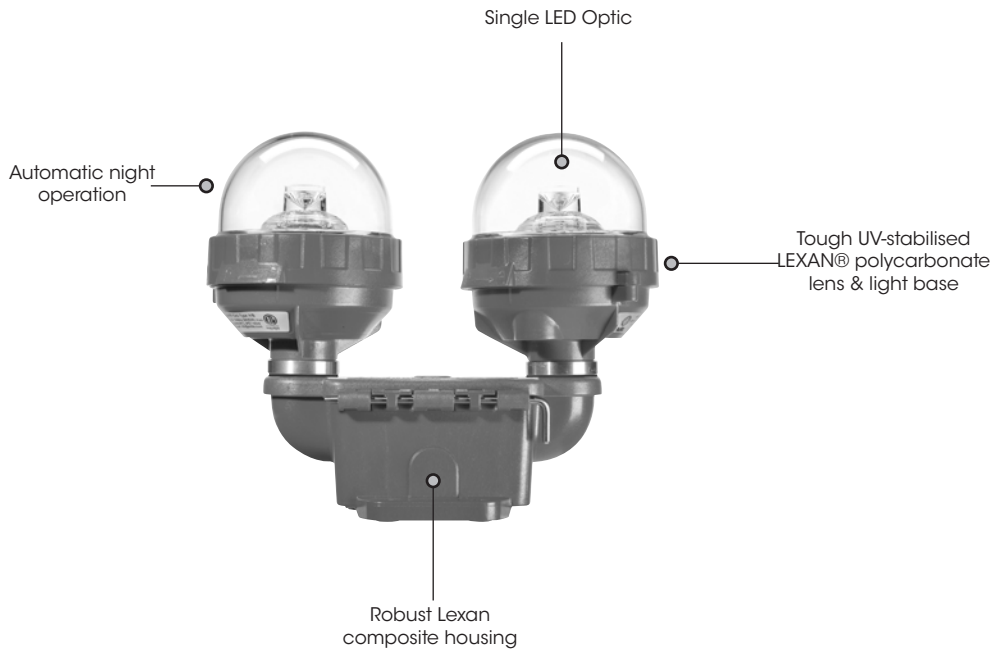

SPECIFICATIONS * *

ICAO Type A & Type B LIOL Dual Fixture

110-240 VAC

Light Characteristics

Light Source	As tested; AV-OL-ILAB-UM-R (Type A & Type B)
Available Colours	Red as standard. Other colours available on request, including IR
Peak Intensity (cd) †	Complies with ICAO LIOLA & LIOLB: 2013
Horizontal Output (degrees)	3600
Vertical Divergence (degrees)	as per ICAO Type A/B specification
Reflector Type	Single LED Optic
Operation Mode Adjustment	User-adjustable between 10cd & 32cd
LED Life Expectancy (hours)	>100,000

Electrical Characteristics

Fallover Configuration @ 12V: Power (W) ‡	ICAO LIOL Type A @ 10cd Steady-on with relay energised: Pmax = 4.2 ICAO LIOL Type B @ 32cd Steady-on with relay energised: Pmax = 7 Smax = 19VA
Dual Lit Configuration @ 12V: Power (W) ‡	ICAO LIOL Type A @ 10cd Steady-on with relay energised: Pmax = 2.4 ICAO LIOL Type B @ 32cd Steady-on with relay energised: Pmax = 8 Smax = 21.3VA
Circuit Protection	Integrated
Operating Voltage	110 - 240 VAC 50/60Hz
Temperature Range	-40 to 80°C

Physical Characteristics

Body Material	Reinforced Polycarbonate composite - UV stabilized
Lens Material	LEXAN® Polycarbonate - UV stabilized
Lens Diameter (mm/inches)	100 / 37/8
Lens Design	Single LED Optic
Mounting	ICAO Model: ¾ inch pipe thread
Height (mm/inches)	ICAO Model: 216 / 8 ½
Width (mm/inches)	259.2 / 10 ¼
Depth (mm/inches)	133 / 5¼
Mass (kg/lbs)	1.15 / 2.53
Product Life Expectancy	12 years plus

Environmental Factors

Humidity	0 to 100%, MIL-STD-810F
Icing	3.41kg per square cm / 48.5lbs per square inch
Wind Speed	Up to 240kph / 150mph

Certifications

CE	EN61000-6-3:2007 EN61000-6-1:2007 FCC 47 CFR Part 15, subpart B
----	---

Quality Assurance	ISO9001:2015
ICAO	Low Intensity Obstruction Light Type A & B
Waterproof	IP67

Intellectual Property

Trademarks	AVLITE® is a registered trademark of Avlite Systems
------------	---

Warranty * *

5 year warranty

Options Available

- Variety of solar/battery configurations
- GSM Cell-Phone Monitoring
- IR LED
- Dual visual/IR output



- Specifications subject to change or variation without notice
- Subject to standard terms and conditions
- † Intensity setting subject to solar availability
- ‡ When used in redundant failsafe mode

SPECIFICATIONS * *

FAA L-810 LIOL Dual Fixture

110-240 VAC

Light Characteristics

Light Source	As tested; FAA: AV-OL-FL810-12-R LED
Available colors	Red as standard. Other colors available on request, including IR
Peak Intensity (cd)†	Complies with FAA L-810 obstruction lights
Horizontal Output (degrees)	360
Vertical Divergence (degrees)	as per FAA L-810 obstruction light specification
Reflector Type	Single LED Optic
Operation Mode Adjustment	User-adjustable between dusk-till-dawn & 24 hour operation
LED Life Expectancy (hours)	>100,000

Electrical Characteristics

Failover Configuration @ 12V: Power (W)‡	FAA L-810 @ 32.5cd Steady-on with relay energized: Pmax = 5 Smax = 13.4VA
Dual Lit Configuration @ 12V: Power (W)‡	FAA L-810 @ 32.5cd Steady-on with relay energized: Pmax = 4 Smax = 10.6VA
Circuit Protection	Integrated
Operating Voltage	110 - 240 VAC 50/60Hz
Temperature Range	-40 to 80°C

Physical Characteristics

Body Material	Reinforced Polycarbonate composite – UV stabilized
Lens Material	LEXAN® Polycarbonate – UV stabilized
Lens Diameter (mm/inches)	100 / 37/8
Lens Design	Single LED Optic
Mounting	FAA Model: ¼ inch pipe thread
Height (mm/inches)	FAA Model: 216 / 8½
Width (mm/inches)	259.2 / 10¼
Depth (mm/inches)	133 / 5¼
Mass (kg/lbs)	1.15 / 2.53
Product Life Expectancy	12 years plus

Environmental Factors

Humidity	0 to 100%, MIL-STD-810F
Icing	3.41kg per square cm / 48.5lbs per square inch
Wind Speed	Up to 240kph / 150mph

Certifications

CE	EN61000-6-3:2007 EN61000-6-1:2007 FCC 47 CFR Part 15, subpart B
Quality Assurance	ISO9001:2015
FAA, DGAC-Mexico	L-810 Medium Intensity Obstruction Light (Qualified by Intertek)
Waterproof	IP67

Intellectual Property

Trademarks	AVLITE® is a registered trademark of Avlite Systems
------------	---

Warranty *

5 year warranty

Options Available

- Variety of solar/battery configurations
- Dual visual/IR output
- IR LED

CE

- Specifications subject to change or variation without notice
- Subject to standard terms and conditions
- † Intensity setting subject to solar availability
- ‡ When used in redundant failsafe mode



Safety Information

- Install the light in compliance with the effective local electrical code(s).
- Mains power should always be disconnected when work is being done in close proximity to electrical fittings, and electrical work should only be done by a licensed and certified professional.
- Operate the light only within the indicated electrical ratings and product usage instructions.
- To ensure that the light and peripheral equipment function safely and correctly, use cable in compliance with the effective local electrical code.
- Do not stare at the LED or shine the LED into your eyes or those of another person.
- Do dispose of the product according to the local laws and regulations for your region, for example, at a recycling center that accepts electronic devices.

Unpacking, Mounting, Installation, Wiring & Setup

Unpacking

Unpack all hardware and inspect for damage. If there is any damage, please contact your Avlite Office. Retain original packing material for possible future use in shipping.

Mounting

Mount the Obstruction Light using its four mounting holes. Make sure the light is horizontally aligned to guarantee the required beam pattern of the obstruction light.

Installation & Wiring

Before proceeding with installation or service, make sure the following conditions are met:

- Ensure the tower or mast is grounded (No RF HAZARD)
- Check the mast lighting circuit is not faulty
- Ensure power lines are not 'live' (NO ELECTRICAL HAZARD)
- Avoid touching live circuits!
- Avoid touching any component or any part of the circuitry while the unit is operating. Do not change components or make adjustments inside the unit with power on.

NOTE:

The unit must be installed by a qualified and certified professional.

OPENING AND CLOSING THE LIGHT HEAD(S)

Remove the locking screw

In order to open the unit, the top half of the unit should be turned anti-clockwise with respect to the bottom half. The top half will turn approximately 20mm over a positive "click" before separating from the bottom half. Attention should be paid to the restriction caused by the internal cabling which is secured by a cable gland.

OPENING AND CLOSING THE LIGHT HEAD(S)

Remove the locking screw

In order to open the unit, the top half of the unit should be turned anti-clockwise with respect to the bottom half. The top half will turn approximately 20mm over a positive "click" before separating from the bottom half. Attention should be paid to the restriction caused by the internal cabling which is secured by a cable gland.

The unit is closed by reversing the above procedure, ensuring the black rubber O-ring remains in place.



Obstruction Light head



Undo the lock nut and locking Pin to remove the lid

Figure 1.

AC POWER CONNECTION

1. Open the top lid by removing a locking pin and nut from one side of the lid. Wire the light and connect the incoming power cable to the terminal block. Refer to figure 2
2. Close the lid using the locking pin and nut. Make sure the white rubber o-ring stays in place during the process

NOTE:

- Use the allocated terminal point on J6 for earth/ground point
- Make sure all wires are secured properly and screws at the switching power supply are tight

NOTE:

- The unit is designed to operate from a nominal AC voltage from 110V-240V.
- Use cable in compliance with the effective local electrical code. The cable outer diameter should be between 5mm and 10mm. Avlite recommends the following number of cores and size[mm²]: 2 x 0.75 or 2 x 1.0
- Colour coding may vary depending on country and local regulations.

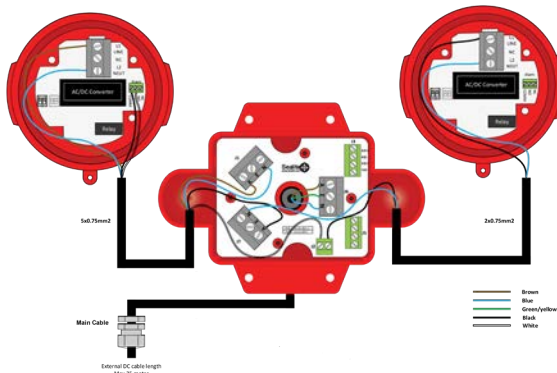
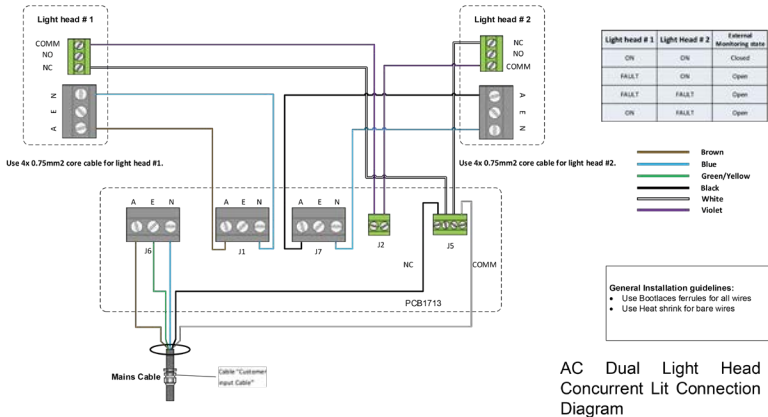
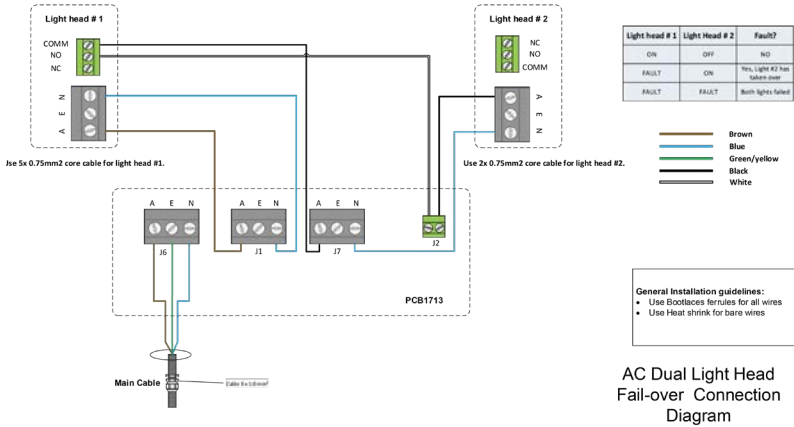

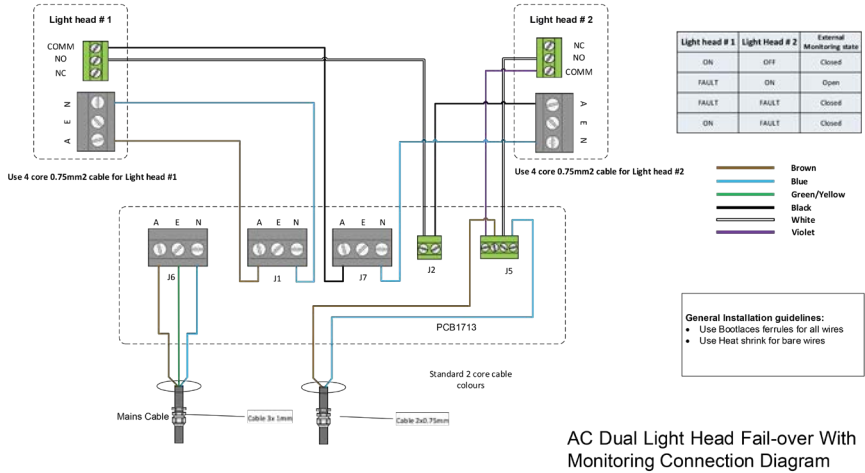

AC Dual Light Head Fail-over With Monitoring Connection Diagram

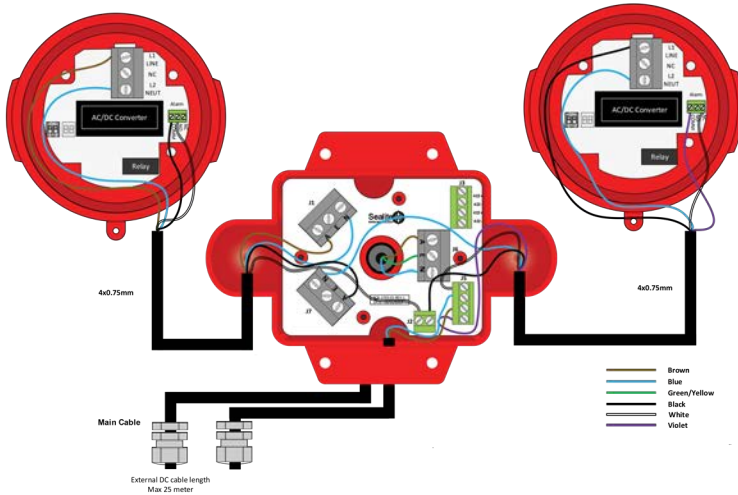

Figure 2. DC Wiring Diagram



Operation & Setup

When powered up, the light will constantly check day/night status using its internal ambient light sensor. The ambient light sensor averages its measurement for 30 seconds.

FAA: By default the lights turn ON when the ambient light decreases to not less than 35 foot-candles (367.7 lux) and turn OFF when the ambient light decreases to not more than 60 foot-candles (645.8 lux). These limits can be factory adjusted, if required.

ICAO: By default the lights turn ON when the ambient light decreases to not less than 35 foot-candles (100 lux) and turn OFF when the ambient light decreases to not more than 60 foot-candles (150 lux). These limits can be factory adjusted, if required.

If the light detects a LED failure the alarm relay can be used to provide a feedback to the user.

INTENSITY & OPERATION MODE SETTING

Light intensity & operation mode setting for ICAO compliant light fixture

The fixture will be supplied with the ICAO compliant optic.

The obstruction light will be pre-set to the intensity setting specified by the customer (ICAO Type A or ICAO Type B) for a red steady burning Low Intensity Obstruction Light in dusk-till-dawn mode. The intensity and operation mode is pre-set in the factory and does not need to be set by the user.

If the customer should need to change the intensity or operation mode settings of the ICAO compliant model they can do this by changing the INTENSITY DIP switch. Please refer to table below for DIP switch settings and Figure 3 for circuit board location.

Position 2	Position 1	Light Intensity
OFF	OFF	ICAO Low Intensity Obstruction Light Type A (10cd), dusk-till-dawn mode – DEFAULT
OFF	ON	ICAO Low Intensity Obstruction Light Type A (10cd), 24 hour mode
ON	OFF	ICAO Low Intensity Obstruction Light Type B (32cd), dusk-till-dawn mode
ON	ON	ICAO Low Intensity Obstruction Light Type B (32cd), 24 hour mode

Light intensity & operation mode setting for FAA compliant light fixture

The fixture will be supplied with the FAA compliant optic.

The FAA compliant model comes pre-set to the correct intensity for L-810 steady burning red obstruction light in dusk-till-dawn mode. The intensity and operation mode is pre-set in the factory and does not need to be set by the user.

If the customer should need to change the operation mode settings of the FAA compliant model they can do this by changing the INTENSITY DIP switch. Please refer to table below for DIP switch settings and Figure 3 for circuit board location.

Position 2	Position 1	Light Intensity
No function	OFF	FAA L-810 Low Intensity Obstruction Light, dusk-till-dawn mode – DEFAULT
No function	ON	FAA L-810 Low Intensity Obstruction Light, 24 hour mode

NOTE:

The ICAO Model and FAA Model have their own unique optic. The ICAO model cannot be used for FAA purposes and the FAA model cannot be used for ICAO purposes. The model required needs to be specified at the time of order.

NOTE:

The unit must be installed by a qualified electrician.

NOTE:

24 hour mode allows remote control via external photocell, RF handheld or external control system.

ALARM RELAY OUTPUT

In normal operation the relay is energised

- Terminal contacts COMM and NC of the relay are electrically closed
- Terminal contacts COMM and NO of the relay are electrically open

Whenever the LED is not lit due to a power failure and/or a LED failure the relay will not be energised.

- Terminal contacts COMM and NO of the relay are electrically closed
- Terminal contacts COMM and NC of the relay are electrically open

For location details of the terminals please refer to Figure 3.

The alarm relay can be configured in three different ways:

- Relay normal operation (default, as described above)
- Relay inverse operation (inverse functionality of the normal operation, used to conserve power)
- Relay disable (in case the relay is not required, used to conserve power)

NOTE: The alarm relay is intended for low voltage (SELV) connection only.

RS232 & RS422/485 COMMUNICATION (OPTIONAL)

The Obstruction Light offers a RS232 and a R2422/485 interface.

RS232 Typical 3 pin TxD, RxD and GND arrangement

RS422/485 Typical 4 pin arrangement with Termination selection and Duplex/Halfduplex selection

For location details please refer to Figure 3.

Duplex		
SW3		
S1	S2	
OFF	OFF	Simplex operation
ON	ON	Duplex operation

Termination		
SW4		
S1	S2	
OFF	OFF	No termination
ON	ON	120 Ohm termination

Please contact AVLITE for further details.

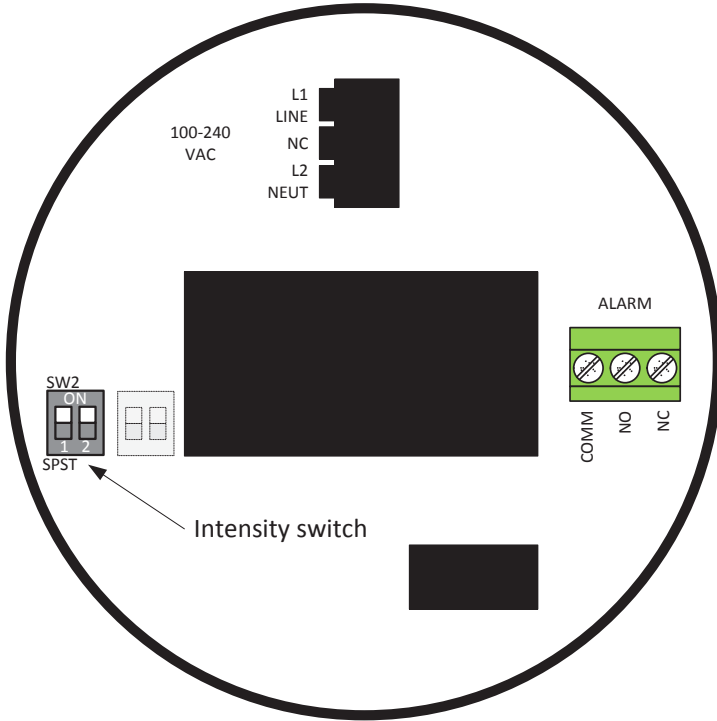

Figure 3. Obstruction Light PCB with terminals and DIP switches



Optional GSM Monitoring & Control System

The AV-OL Series Dual Light Fixture may also be fitted with GSM Cell-Phone Monitoring and Control – enabling users to access real-time diagnostics data and change light settings via cell-phone. The system can also be configured to send out alarm SMS text messages to designated cellular telephone numbers. Users can also have alarms and reports sent to designated email addresses.

Please contact Avlite for further information and instructions.



Maintenance & Servicing

Designed to be maintenance free the Obstruction Lights require minimal attention, though the following maintenance and servicing information is provided to help ensure the life of your Avlite product.

- Occasional cleaning of the dome lens may be required using a cloth and warm soapy water as needed.



Trouble Shooting

Problem	Remedy
Light will not activate.	<ul style="list-style-type: none">• Ensure proper connectivity with power supply• Ensure that the power supply has the right polarity and voltage range• Cover the light sensor to force the light ON

Appendix

Wiring Diagram

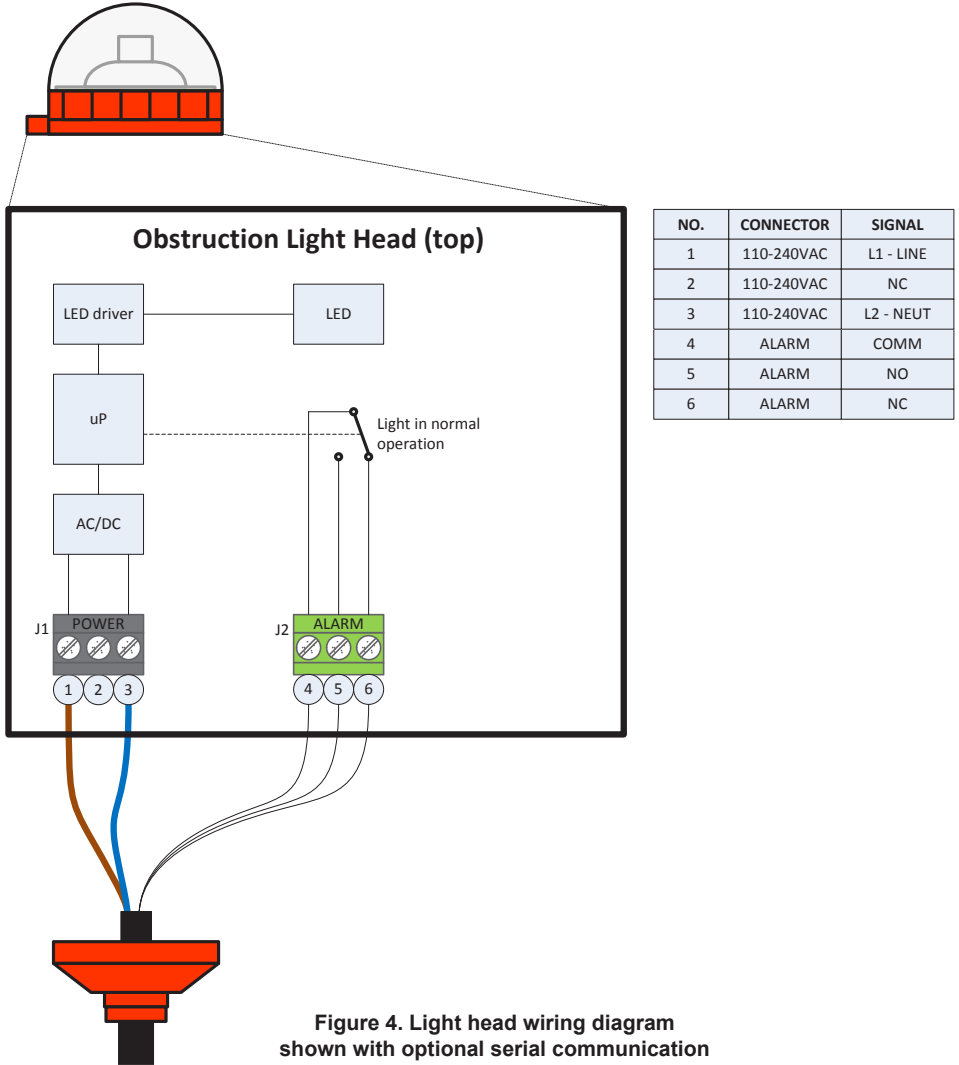

Figure 4. Light head wiring diagram shown with optional serial communication

Light Head Parts Diagram

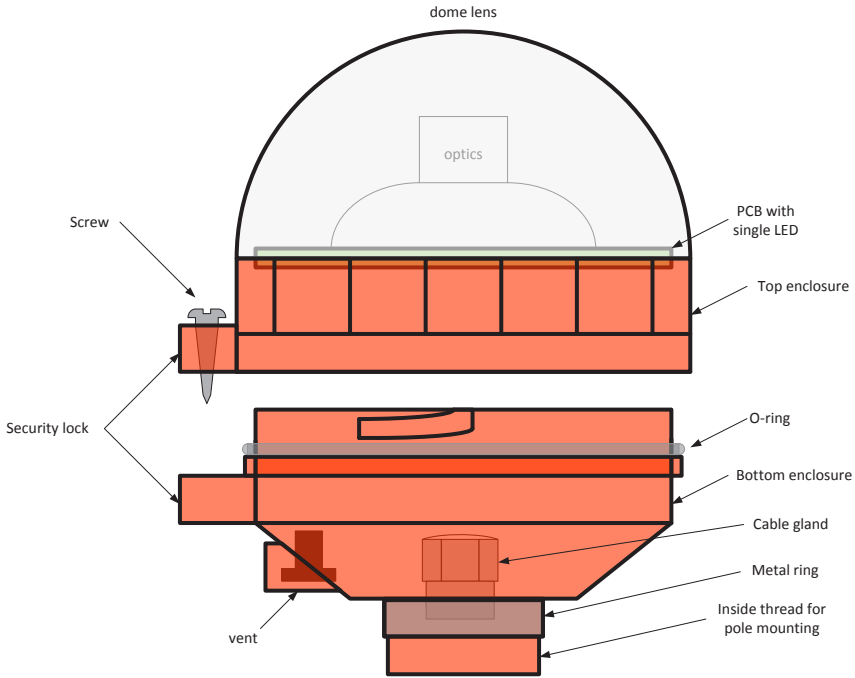

Figure 5. Light head parts diagram

Main Enclosure Parts Diagram

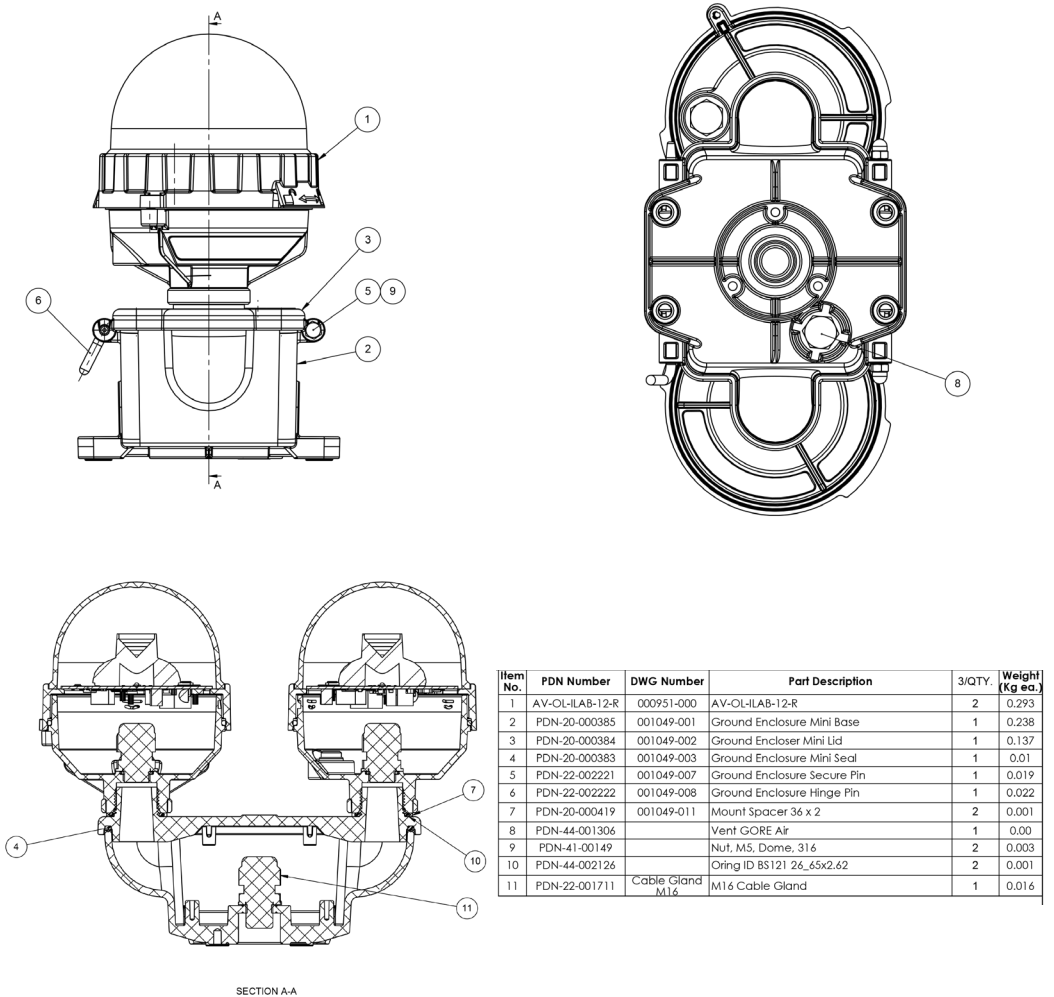

Figure 6. Parts diagram of the main enclosure

Product Order Codes

HOW TO ORDER AV-OL Series Obstruction Lights:

ICAO Compliant

FAA Compliant

AV-OL-ILAB-[Model]-[Color]-[?]-[?]-[?]-[?]-[?]

AV-OL-FL810-[Model]-[Color]-[?]-[?]-[?]-[?]-[?]

Product No.: _____

Product No.: _____

Model: _____

Model: _____

12 = 12-48 VDC
UM = 110-240 VAC

12 = 12-48 VDC
UM = 110-240 VAC

Color: _____

Color: _____

R = Red
IR = Infrared
RIR = Combined Red/IR

R = Red
IR = Infrared
RIR = Combined Red/IR

Single or Dual Fixture: _____

Single or Dual Fixture: _____

[blank] = Single light fixture
[D] = Dual light fixture

[blank] = Single light fixture
[D] = Dual light fixture

Solar/Battery Configuration: _____

Solar/Battery Configuration: _____

CT1 = Type 1
CT2 = Type 2
[blank] = No solar/battery configuration

CT1 = Type 1
CT2 = Type 2
[blank] = No solar/battery configuration

Monitoring & Control: _____

Monitoring & Control: _____

G = GSM
RF = Radio Control
[blank] = No monitoring & control

G = GSM
RF = Radio Control
[blank] = No monitoring & control

RS Communications Port (12-48VDC Model only): _____

RS Communications Port (12-48VDC Model only): _____

RS = RS communications port
[blank] = No RS communications port

RS = RS communications port
[blank] = No RS communications port

Feature: _____

Feature: _____

0 = Both lights activated at the same time
1 = One light activated with automatic changeover ability
[blank] = No feature

0 = Both lights activated at the same time
1 = One light activated with automatic changeover ability
[blank] = No feature

Certifications & Compliance

Certified to: FAA AC NO: 150/5345-43G L-810 (L)
FAA Engineering Brief No. 67
FAA Engineering Brief No. 76 (if applicable)
DGAC L-810

Compliant to: Low Intensity Type A & B Obstruction Light, ICAO Annex 14, Volume 1, Sixth Edition, July 2013, 'Aerodrome Design and Operations



Certifications & Compliance

Certified to: FAA AC NO: 150/5345-43G L-810 (L)
FAA Engineering Brief No. 67
FAA Engineering Brief No. 76 (if applicable)
DGAC L-810

Compliant to: Low Intensity Type A & B Obstruction Light, ICAO Annex 14, Volume 1, Sixth Edition, July 2013, 'Aerodrome Design and Operations



Avlite Light Warranty V1.2

Activating the Warranty

Upon purchase, the Avlite Systems warranty must be activated for recognition of future claims. To do this you need to register on-line. Please complete the Online Registration Form at:

www.avlite.com

Avlite Systems will repair or replace your lantern in the event of electronic failure for a period of up to three years from the date of purchase.

Avlite Systems will repair or replace any ancillary or accessory products in the event of failure for a period of up to one year from the date of purchase, as per the terms & conditions below.

The unit must be returned to Avlite freight prepaid.

Warranty Terms

1. Avlite Systems warrants that any Avlite aviation products fitted with telemetry equipment including but not limited to AIS, GSM, GPS or RF ("Telemetry Products") will be free from defective materials and workmanship under normal and intended use, subject to the conditions hereinafter set forth, for a period of twelve (12) months from the date of purchase by the original purchaser.
2. Avlite Systems warrants that any rotationally-moulded products ("Roto-Moulded Products") and accessory products ("Accessory Products") will be free from defective materials and workmanship under normal and intended use, subject to the conditions hereinafter set forth, for a period of twelve (12) months from the date of purchase by the original purchaser.
3. Avlite Systems warrants that any Avlite aviation products other than the Telemetry Products, Roto-Moulded Products and Accessory Products ("Avlite Products") will be free from defective materials and workmanship under normal and intended use, subject to the conditions hereinafter set forth, for a period of three (3) years from the date of purchase by the original purchaser.
4. Avlite Systems will repair or replace, at Avlite's sole discretion, any Telemetry Products, Roto-Moulded Products, Accessory Products or Avlite Products found to be defective in material and workmanship in the relevant warranty period so long as the Warranty Conditions (set out below) are satisfied.
5. If any Telemetry Products or Avlite Products are fitted with a rechargeable battery, Avlite Systems warrants the battery will be free from defect for a period of one (1) year when used within original manufacturer's specifications and instructions.

Warranty Conditions

This Warranty is subject to the following conditions and limitations;

1. The warranty is applicable to lanterns manufactured from 1/1/2009.
2. The warranty is void and inapplicable if:
 - a. the product has been used or handled other than in accordance with the instructions in the owner's manual and any other information or instructions provided to the customer by Avlite;
 - b. the product has been deliberately abused, or misused, damaged by accident or neglect or in being transported; or
 - c. the defect is due to the product being repaired or tampered with by anyone other than Avlite or authorised Avlite repair personnel.
3. The customer must give Avlite Systems notice of any defect with the product within 30 days of the customer becoming aware of the defect.
4. Rechargeable batteries have a limited number of charge cycles and may eventually need to be replaced. Typical battery replacement period is 3-4 years. Long term exposure to high temperatures will shorten the battery life. Batteries used or stored in a manner inconsistent with the manufacturer's specifications and instructions shall not be covered by this warranty.
5. No modifications to the original specifications determined by Avlite shall be made without written approval of Avlite Systems.
6. Avlite lights can be fitted with 3rd party power supplies and accessories but are covered by the 3rd



- party warranty terms and conditions.
7. The product must be packed and returned to Avlite Systems by the customer at his or her sole expense. Avlite Systems will pay return freight of its choice. A returned product must be accompanied by a written description of the defect and a photocopy of the original purchase receipt. This receipt must clearly list model and serial number, the date of purchase, the name and address of the purchaser and authorised dealer and the price paid by the purchaser. On receipt of the product, Avlite Systems will assess the product and advise the customer as to whether the claimed defect is covered by this warranty.
 8. Avlite Systems reserves the right to modify the design of any product without obligation to purchasers of previously manufactured products and to change the prices or specifications of any product without notice or obligation to any person.
 9. Input voltage shall not exceed those recommended for the product.
 10. Warranty does not cover damage caused by the incorrect replacement of battery in solar lantern models.
 11. This warranty does not cover any damage or defect caused to any product as a result of water flooding or any other acts of nature.
 12. There are no representations or warranties of any kind by Avlite or any other person who is an agent, employee, or other representative or affiliate of Avlite, express or implied, with respect to condition of performance of any product, their merchantability, or fitness for a particular purpose, or with respect to any other matter relating to any products.

Limitation of Liability

To the extent permitted by acts and regulations applicable in the country of manufacture, the liability of Avlite Systems under this Warranty will be, at the option of Avlite Systems, limited to either the replacement or repair of any defective product covered by this Warranty. Avlite Systems will not be liable to Buyer for consequential damages resulting from any defect or deficiencies in accepted items.

Limited to Original Purchaser

This Warranty is for the sole benefit of the original purchaser of the covered product and shall not extend to any subsequent purchaser of the product.

Miscellaneous

Apart from the specific warranties provided under this warranty, all other express or implied warranties relating to the above product is hereby excluded to the fullest extent allowable under law. The warranty does not extend to any lost profits, loss of good will or any indirect, incidental or consequential costs or damages or losses incurred by the purchaser as a result of any defect with the covered product.

Warrantor

Avlite Systems has authorised distribution in many countries of the world. In each country, the authorised importing distributor has accepted the responsibility for warranty of products sold by distributor. Warranty service should normally be obtained from the importing distributor from whom you purchased your product. In the event of service required beyond the capability of the importer, Avlite Systems will fulfil the conditions of the warranty. Such product must be returned at the owner's expense to the Avlite Systems factory, together with a photocopy of the bill of sale for that product, a detailed description of the problem, and any information necessary for return shipment.

Universal AC Low Intensity Obstruction Light Dual Light Fixture



Head Office

Avlite Systems
11 Industrial Drive
Somerville, Vic 3912
Australia

Tel: +61 (0)3 5977 6128
Fax: +61 (0)3 5977 6124

Email: info@avlite.com
Internet: www.avlite.com

A subsidiary of Sealite Pty Ltd www.sealite.com

Latest products and information available at www.avlite.com