

Avlite[®]
www.avlite.com



AV-C310-ILA & AV-C410-ILAB
Solar Powered
ICAO Low Intensity Obstruction Light Type A/B
Installation & Service Manual

Version 1.1

Version No.	Description	Date	Approved
1.0	Manual launch	March 2012	C. Procter
1.1	IR controller instructions	April 2012	C. Procter
1.2	Lux Table added	April 2012	J. Dore
2.0	Product Code change	October 2012	J. Dore
2.1	GPS Option	November 2012	J. Dore
2.2	Update: Spec table	January 2013	J. Dore
2.3	Update: Selecting an intensity & flash code	May 2013	P. Rainey
2.4	GSM option	October 2013	S. Turner
2.5	Update: Torque setting	February 2014	P. Rainey

Table of Contents

Introduction	Page 4
Operating Principle	Page 4
Technology	Page 4
AV-C310-ILA & AV-C410-ILAB Model	Page 5
AV-C310-ILA & AV-C410-ILAB Optional Configurations	Page 8
Activation	Page 9
Installation	Page 10
Selecting an Operation Mode & Type	Page 11
Selecting a flash code - Rotary switches A & B	Page 12
Lantern Status	Page 13
Optional IR Remote Control	Page 14
Avlite IR Controller / Universal Remote Compatibility	Page 14
IR Controller Functions	Page 15
Test Mode / Configure	Page 15
Normal Operation	Page 15
Read	Page 15
Battery Status	Page 15
Lux	Page 16
Error/Acknowledge Indication	Page 17
Hibernation Mode (Advanced Users)	Page 17
Storage Mode (Advanced Users)	Page 20
Set Operation Mode	Page 20
Optional GSM Monitoring: AV-C410-ILAB Model	Page 21
Maintenance and Servicing	Page 22
Replacing the Battery	Page 22
Long Term Battery Storage	Page 23
Solar Panel Replacement	Page 24
How to Change the Regulator	Page 25
Trouble Shooting	Page 26
AV-SB-10 Solar Booster	Page 27
Solar Booster Installation Procedure	Page 29
Avlite Light Warranty	Page 30



Introduction

Congratulations! By choosing to purchase an Avlite light, you have become the owner of one of the most advanced solar LED airfield lights in the world.

Avlite Systems draws on more than 25 years experience in the design and manufacture of navigation aids, and particular care has been taken to ensure your light gives years of trouble free service.

As a commitment to producing the highest quality products for our customers, Avlite has been independently certified as complying with the requirements of ISO 9001:2008 quality management system.

By taking a few moments to browse through this booklet, you will become familiar with the versatility of your light, and be able to maximise its operating function.

Please remember to complete the Avlite warranty registration card accompanying your light.

Operating Principle

The solar module of the light converts sunlight to an electrical current that is used to charge the battery. The battery provides power to operate the light at night.

The flasher unit has very low current requirements. A microprocessor drives an ultra bright LED through a DC/DC converter, which enables the LEDs to operate within the manufacturer's specifications. The battery is protected from over-charging within the circuit to ensure maximum battery life.

On darkness, the microprocessor will initiate a program check and after approximately 1 minute will turn on.

Technology

Avlite Systems is a world-class solar lighting systems manufacturer with a proven reputation for rapid, innovative, and agile technology solutions designed specifically for defense, government, civil and humanitarian aid operations in the most remote, toughest environments.

Electronics

Avlite employs leading in-house electronic engineers in the design and development of software and related circuitry. All individual electronic components are sourced directly by Avlite procurement staff ensuring that only the highest quality components are used in our products.

LED Technology

All aviation lights use the latest advancements in LED (Light Emitting Diode) technology as a light source. The major advantage of LEDs over traditional light sources is well established in that they typically have an operational life in excess of 100,000 hours, resulting in substantial savings to maintenance and servicing costs.

Precision Construction

Commitment to investing in the design and construction of injection-moulded parts including optic lenses, light bases and a range of other components ensures that all Avlite products are of a consistent and superior quality.

Optical Performance

Avlite manufactures a range of aviation LED lenses moulded from multi-cavity dies. The company has superior in-house lens manufacturing capabilities to support outstanding optical performance.

Award-winning, Patented Technology

Several United States and Australian patent registrations are held on Avlite's range of innovative designs, with other regional patents pending in Canada, United Kingdom and Europe.

AV-C310-ILA & AV-C410-ILAB Model

Avlite's Solar powered ICAO LIOL (available as type A only on the 310 chassis and Type A and B on the 410 chassis) is a robust, completely self-contained solar powered LED obstruction light.

The AV-C310-ILA model has four 3 watt (12watt total) premium-grade solar modules integrated into the solar chassis, and mounted to collect sunlight at all angles. This unit complies with the requirements for ICAO low intensity obstruction lights type A. The AV-C410-ILAB model has four larger 5watt panels (20 watt total) for use in areas of lower sunlight to maximise solar collection. This unit complies with the requirements for ICAO low intensity obstruction lights type A and B.

The solar array charges an internal battery during daylight hours, and at dusk the light will automatically begin operation.

The rugged design of this self-contained light ensures up to 12 years of reliable service with minimal ongoing maintenance.

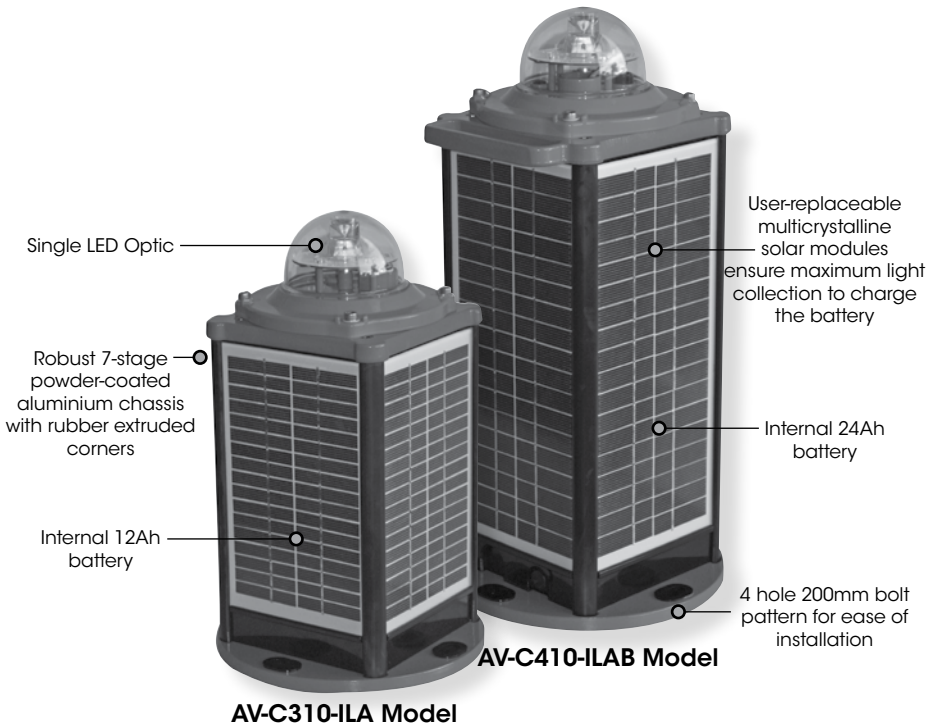

Figure 1.

SPECIFICATIONS * ***AV-C310-ILA****AV-C410-ILAB****Light Characteristics**

Light Source
Available colors

Peak Intensity (cd)†
Horizontal Output (degrees)
Vertical Divergence (degrees)
Reflector Type
LED Life Expectancy (hours)

Electrical Characteristics

Current Draw (mA)
Circuit Protection
Operating Voltage (V)
Temperature Range

Solar Characteristics

Solar Module Type
Output (watts)
Solar Module Efficiency (%)
Charging Regulation

Power Supply

Battery Type
Battery Capacity (Ah)
Nominal Voltage (V)
Typical Autonomy (nights)
Approx. daily insolation to maintain full autonomy (kWh/m²)

Physical Characteristics

Body Material
Lens Material

Lens Diameter (mm/inches)
Lens Design
Mounting
Height (mm/inches)
Width (mm/inches)
Mass (kg/lbs)
Product Life Expectancy

Environmental Factors

Humidity
Icing
Wind Speed
Shock

Vibration

Certifications

CE
Quality Assurance
ICAO

Waterproof

Intellectual Property

Trademarks

Warranty ***Options Available**

As tested AV-OL-ILA-12-R LED
Red as standard. Other colors available on request, including IR
Complies with ICAO LIOLA
360
+4 to +13
Single LED Optic
>100,000

Steady-on: 39 for LIOLA
Integrated
12
-40 to 80°C

Multicrystalline
12 (4 x 3watt)
14
Microprocessor controlled

SLA (Sealed Lead Acid)
12
12
Steady-on: >20
2.2

7-stage powder-coated aluminium
LEXAN® Polycarbonate
- UV stabilized
107 / 4¼
Single LED Optic
4 x 17mm holes on 200mm PCD
375 / 14¾
233 / 9¼
9.1 / 20
Up to 12 years

0 to 100%, MIL-STD-810F
22kg per square inch
Up to 160kph
MIL-STD-202G, Test Condition H, Method 213B
MIL-STD202G, Test Condition H, Method 204

EN61000-6-3:1997. EN61000-6-1:1997
ISO9001:2015
Low Intensity Obstruction Light Type A

IP68

AVLITE® is a registered trademark of Avlite Systems
3 year warranty
• IR Controller
• IR LED
• External ON/OFF Switch
• External Battery Charging Port

As tested AV-OL-ILAB-12-R LED
Red as standard. Other colors available on request, including IR
Complies with ICAO LIOLA+B
360
+4 to +13
Single LED Optic
>100,000

Steady-on: 39 for LIOLA
Integrated
12
-40 to 80°C

Multicrystalline
20 (4 x 5watt)
14
Microprocessor controlled

SLA (Sealed Lead Acid)
24
12
Steady-on: >40
1.4
0.7 (with Solar Booster™)

7-stage powder-coated aluminium
LEXAN® Polycarbonate
- UV stabilized
107 / 4¼
Single LED Optic
4 x 17mm holes on 200mm PCD
470 / 18½
233 / 9¼
13.9 / 30½
Up to 12 years

0 to 100%, MIL-STD-810F
22kg per square inch
Up to 160kph
MIL-STD-202G, Test Condition H, Method 213B
MIL-STD202G, Test Condition H, Method 204

EN61000-6-3:1997. EN61000-6-1:1997
ISO9001:2015
Low Intensity Obstruction Light Type A+B

IP68

AVLITE® is a registered trademark of Avlite Systems
3 year warranty
• IR Controller
• GSM Cell-Phone Monitoring
• IR LED
• External ON/OFF Switch
• External Battery Charging Port
• Solar Booster™

• Specifications subject to change or variation without notice
* Subject to standard terms and conditions
† Intensity setting subject to solar availability



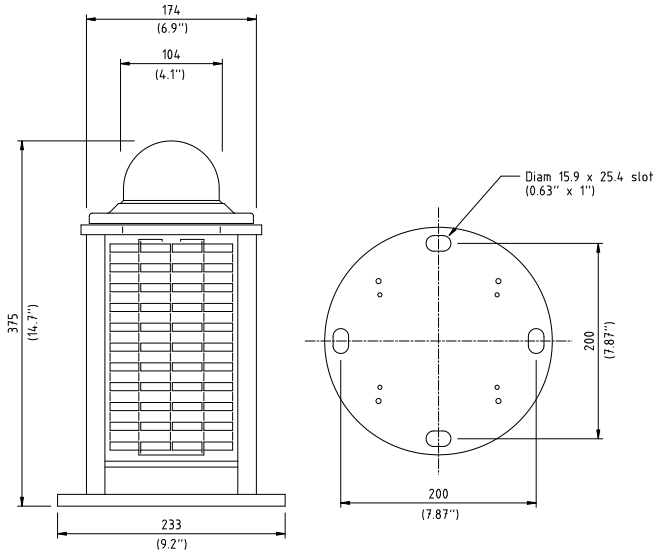

Figure 2. AV-C310-ILA Model

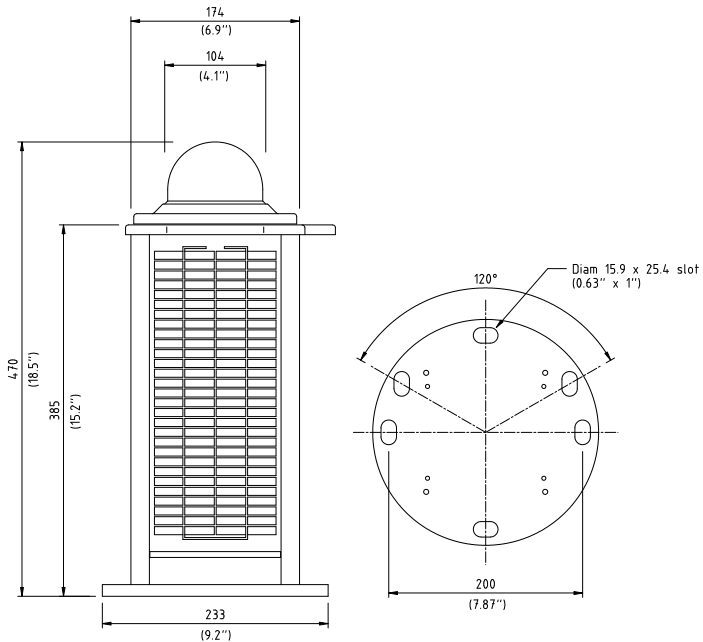

Figure 3. AV-C410-ILAB Model



AV-C310-ILA & AV-C410-ILAB Optional Configurations

Optional External ON/OFF Switch

The AV-C310-ILA and AV-C410-ILAB can be fitted with an external ON/OFF switch below the solar panel at the base of the unit. The ON/OFF switch may be useful if the unit is only required for short periods and is often being moved or needs to be stored often, and disconnecting the battery is not viable.

Optional External Battery Charging Port

The AV-C310-ILA and AV-C410-ILAB can be fitted with an external battery charging port MIL-STD 2Pin connector. (ITT Cannon Part Number = MS3111E8-2P)

It is found below the solar panel at the base of the unit.

If the light is being stored for more than 1 month then the battery should be regularly recharged. Please see 'Long Term Battery Storage' in the Maintenance & Servicing section of this manual.

You may purchase a suitable battery charger from Avlite

Or/

Use a connector that mates with the 2Pin connector on the unit.

Pin 1(A) = Battery Positive (+)

Pin 2 (B) = Battery Negative (-)

Optional IR Remote Control

The IR remote is used to communicate with Avlite lighting products that have an IR sensor fitted. The remote control is used to control functions such as flash code and light intensity.

Optional GSM Cell-Phone Monitoring (AV-C410-ILAB Model only)

GSM Cell-Phone Monitoring enables operators to remotely monitor the status of their installations. The system can also be configured to send out alarm SMS text messages to designated cellular telephone numbers. Users can also have alarms and reports sent to designated email addresses.

Activation

Charging the Battery

New lights should be left in the sun for 1-2 days to ensure battery is charged before placing in service. Please note, light will re-charge even when toggle switch is turned to 'OFF' position.

Preferred Installation Location

For best light performance, ensure solar modules are not covered and are in clear view of the sky with no shadows.

The AV-C310-ILA and AV-C410-ILAB are designed as an obstruction light. The unit can also be supplied in varying color outputs to suit other applications including runway edge lighting.

Light Operation

The light is activated by connecting the 4Pin battery connector inside the unit.

Please follow the steps under 'Selecting an operational mode and type section of the manual'.

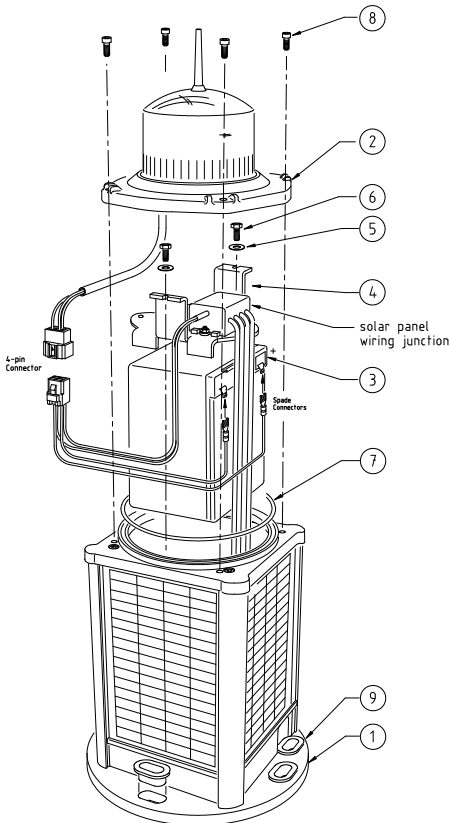

Item	Description	Quantity
1	AV-C310-ILA/AV-C410-ILAB Base	1
2	AV-C410-ILAB Lens Assembly	1
3	Battery	1
4	Battery Clamp	1
5	Washer M4	2
6	M4 Cap Screw	2
7	O-Ring, ID 145 x 4.0	1
8	Socket Head Screw M6 x 16	4
9	Mounting Insert	4

Figure 4. AV-C310/AV-C410-ILAB Solar light components



Installation

Installing the Light Assembly to the Rubber Tile

The completed light – rubber tile assembly is to be mounted on a surface capable of supporting 20kg minimum. Securing the rubber tile to the mounting surface is optional, however, Avlite recommend that the tile be secured at a minimum of two points.

- a. Insert bolts through the 4 x holes in the tile, entering from the bottom face (within the recess). It may be necessary to use a rubber mallet to insert the bolts.
- b. Fit the light over the bolts on the top face of the tile.
- c. Install a penny washer and a Nylock nut on each bolt. Tighten nuts to finger-tightness.
- d. Place the completed light assembly in the desired location.
- e. Using a hammer, drive steel pegs through the holes in the corners of the rubber tile being careful not to damage the solar panels.

Note: - Other means of securing the tile may be used where the mounting surface is not suited to the use of steel pegs.

Installing the Light Assembly to the Frangible Stake Mount

The completed light - mount plate assembly is to be mounted on the stake in firm soil (not loose sand, screenings or other unbound material).

- a. Fit the light on the top of the mounting plate. Insert bolts through the four holes in the mount, entering from the bottom. Install a penny washer and a Nylock nut on each bolt. Tighten Nylock nuts.
- b. Use a sledge hammer to drive the stake into the soil at the chosen location. Drive the stake down until the bottom of the stake sleeve is at ground level.
- c. Fit the boss of the mount plate into the shorter barrel of the frangible sleeve. Using a 6mm allen key, tighten the socket head cap screw against the stake mount boss.
- d. Fit the light and mounting plate assembly on top of the stake. The longer barrel of the frangible sleeve should completely cover the stake sleeve. Using a 6mm allen key, tighten the bottom socket head cap screws against the stake sleeve.

Selecting an Operation Mode & Type

1. Remove the four socket-head cap screws on the lens assembly.
2. Remove the flash adjustment plug from the underside of the light head.
3. The DIP switches control the Operational Modes and the Type of Obstruction Light required.
4. Operation mode can be set to either "Always On" or "Dusk to Dawn"
 - Always On = 0 (Important: Lights left in this state must only be used for short periods)
 - Dusk to Dawn = 1
5. ICAO Obstruction Light Type can be set to either Type A or Type B
 - Type B = N (Important: Type B operation is not recommended for the C310-ILA chassis. Please only select Type B for the C410-ILAB chassis)
 - Type A = 2
6. Set the Dip Switches to the required settings.
7. The Rotary Switches must be left on 0,0 to comply with the requirements for ICAO LIOL.
8. Replace the Flash Adjustment Bung.
9. Connect the 4Pin connector to power up the unit.
10. Place the top lens assembly back onto the light body and replace 4 x socket head screws. It is recommended that the bolts for holding the light heads to the Solar Base units have a torque setting applied of 3Nm for a satisfactory seal.

Applying a higher Torque setting is not recommended and may void warranty. If in doubt, please contact your local Avlite representative.

Make sure the O-ring is fitted correctly in the O-ring groove.
11. The unit is now ready for normal operation, once placed in darkness.
12. To test place dark cover (towel or jacket) on top of light to activate sensor; light will come on.

The following diagrams indicate pulse settings:-

Fig 1 shows the typical settings used in the AV-C410-ILAB

Operation Mode = Dusk to Dawn and Type = B

Fig 2 shows the typical settings used in the AV-C310-ILA

Operation Mode = Dusk to Dawn and Type = A

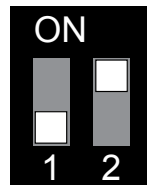

Fig 1

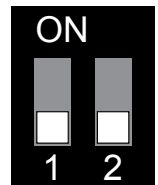

Fig 1

Selecting a flash code - Rotary switches A & B

All lights have 2 rotary switches marked A and B on the flasher unit. Turning the small arrows to the appropriate number or letter will set the code. The unit may take up to one minute to activate a new flash code. Set switches to 0,0 for steady-on.

Example:

SWITCH		FLASH CODE	ON	OFF
A	B			
A	0	FL 3 S	0.3	2.7

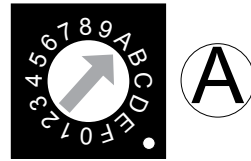
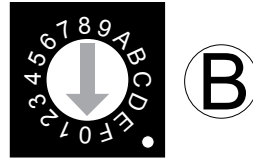

Note:

The AV-C310-ILA/AV-C410-ILAB is supplied preset to meet ICAO Low Intensity Type A applications. This correlates to 100% intensity setting + flash code steady-on (0,0).

Lantern Status

Two status LED's on the main printed circuit board provide the operator with an indication of the lantern status.

There is one red and one yellow status LED. The red status LED is used to indicate the health of the lantern's power system. The yellow status LED is used to indicate the operational status of the lantern.

Avlite boards are fitted with two Indicator LED's. These are positioned near the Flash Code Rotary Switches. Use the table below to help determine operational status.

Yellow LED	Lantern Status	Lantern	Comment
OFF	Normal	OFF	Lantern is in Daylight and in Dusk till Dawn mode or in Standby Mode
Flashing ON 0.15 seconds OFF 0.15 seconds	Normal	OFF	Light is activating and will turn on after detecting 30 seconds of continuous darkness.
Flashing 2 x quick flashes every 2 seconds (Heartbeat)	Normal	ON	Lantern is in Normal operating condition. It is not connected to any GPS synchronisation.
Flashing ON 1.5 seconds OFF 1.5 seconds	Normal	ON	Normal operating condition. Lantern is synchronised to GPS-enabled lanterns.
Flashing 1 x quick flash every 2 seconds	Normal	ON	Lantern is 're-syncing' with GPS. The lantern re-sync's with the GPS every 15 minutes.
Flashing 2 x quick flashes every 11 seconds	Normal	ON	Lantern is a Hard Wire Synchronisation Slave.

Red LED	Lantern Status	Lantern	Comment
OFF	Normal		Normal Battery Voltage
Flashing once every 1.6 seconds	Battery Voltage is 12 – 12.5V		Battery Voltage is between 12 – 12.5V
Flashing twice every 2 seconds	Battery Voltage is 11.5 – 12V		Battery Voltage is between 11.5 – 12V
Flashing 3 x times every 2 seconds	Battery Voltage is 10.0 – 11.5V		Battery Voltage is between 10.0 – 11.5V
Flashing 4 x times every 2.5 seconds	Battery Voltage is <10.0V		Battery Voltage is less than 10.0V
Fixed-on	Flat Battery (<10V)	OFF	Flat Battery cut-off is now operational and the lantern will be off. Battery must receive charge (above 12V) and lantern must see daylight for at least 1 minute before resuming normal operation.
Flashing ON 1.5 seconds OFF 1.5 seconds	Battery Voltage is above 13.5V		Battery Voltage is above 13.5V. this may indicate a problem with the solar regulator.

Optional IR Remote Control

The IR remote is used to communicate with Avlite lighting products that have an IR sensor fitted. The remote control is used for the following functions:

- Operational Mode: sets the operational mode - always on, dusk to dawn, or standby.
- Ambient Light Thresholds: read the current light thresholds, configure new ambient light thresholds.
- Perform a battery health check.

On receiving a valid key signal from the IR Remote, the light will flash once. The user should wait until the light responds to each keypress before pressing another key. If there is no response to the keypress after 3 seconds, it has not been detected by the light and the key can be pressed again.

If an invalid key is detected, the light will flash quickly 5 times. In this case, the command will have to be restarted.

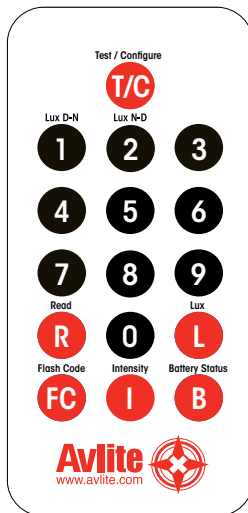

Avlite IR Controller / Universal Remote Compatibility

If you lose your Avlite IR Controller, the following Universal Remote Controller has been tested for compatibility: RCA Type RCR312WR programmed for Phillips TV Type Code 10054

Avlite Key	Universal Remote Key
T	Power
1	1
2	2
3	3
4	4
5	5
6	6
7	7
8	8
9	9
0	0
R	Channel+
L	Mute
FC	Volume+
I	Volume-
B	Channel-



IR Controller Functions

Test Mode / Configure



Pressing the T/C button for up to 5 seconds places the light in Test Mode. The light will flash once in response to the T/C button being pressed and then turn off.

Normal Operation

The light will return to normal operation once it has not detected a valid key press for 15 seconds. The light will flash once to indicate it is returning to normal operation.

Read

Pressing the Read followed by one of the configuration keys shall cause the light to flash the configured value.

Example Key Sequences:



The light flashes the current battery status.

Battery Status



This function reads the battery status. The response from the light is:

4 = HIGH (>4.0V)

3 = OPTIMAL/GOOD (3.6V to 4.0V)

2 = BELOW GOOD (3.2V to 3.6V)

1 = FLAT (<3.2V)

Example Key sequence:



Lux



This key sets the ambient light threshold levels.

The format is



Where 'x' is the desired setting from the table below.

Level	Sunset (Dusk)	Sunrise (Dawn)
1	64	100
2*	100	150
3	150	240
4	240	370
5	370	600
* Default / Factory Preset		

There are 5 programmable lux levels which are set together for the sunset and sunrise transitions.

Example key sequence:



Assume the current Lux settings are at the factory preset values of 2.

This sets the ambient light level to be lower than the default 100 lux. This means that the ambient light level will be lower (ie. it is darker) before the light turns on.

The light responds by acknowledgement with a long flash.



Error/Acknowledge Indication

If the key sequence is invalid, or an out of bounds value is attempted to be set, the light flashes 5 times for 1 second. (The command then needs to be sent from the start.)

Example key sequence: (Set the intensity level to 5 – undefined.)



The light flashes 5 times for 1 second.

When a key sequence has been entered successfully the light will respond acknowledgement with a long 1 second flash.

Hibernation Mode - only available with GPS option fitted (Advanced users)



For situations where the lantern is put into storage for a known period, the IR Remote control can be used to configure the lantern into Hibernation Mode for a user programmable date range.

Hibernation Mode maximises conservation of the battery power by disabling the light (will not activate at night) and shutting off the GPS receiver to rely on the internal clock for date checking. The IR sensor is still monitored in hibernation mode. Power consumption is only bettered by physically disconnecting the battery supply.

Hibernation Mode is defined by a start date and end date that are programmed into the lantern via the IR Remote Control.

Using the IR Remote Control

The lantern must be in Test Mode prior to pressing any of the following key sequences. However, the lantern will return to Normal Operation if it has not detected a valid key press for a period of 15 seconds. When the lantern exits from Test Mode it will either enter Dusk to Dawn mode, Hibernation mode, or Storage Mode, if enabled.

Store Hibernation Mode Date Range

The following details the key press sequence that defines the start and end dates of Hibernation Mode:



where **ddmm** is the numerical representation of the month (01=January, 08=August) of the start date, and **DDMM** is the numerical representation of the end date.

e.g 9th of December is represented by the number sequence 0912.

The lantern will respond by flashing an acknowledge long flash.

This operation only stores the start & end dates into the lantern's memory and Hibernation Mode still must be enabled to commence its operation.

Enable Hibernation Mode

Pressing the following key sequence will enable (turn on) Hibernation Mode:



and the lantern will respond with a single flash.

The Lantern will take a new GPS reading, determine the calendar month, and then enter Hibernation Mode and depending on the current calendar month setting will either Hibernate or enter Dusk-to-Dawn mode.

By default, Hibernation mode is disabled. Note you can only use this command once a valid hibernation start & end date has been stored in the lantern.

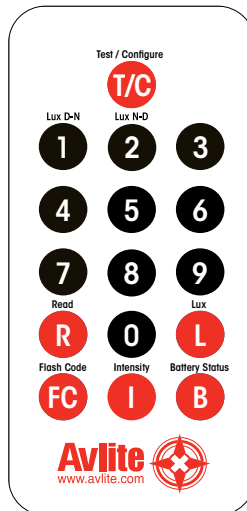

Disable Hibernation / Hibernation Modes

Pressing the following key sequence will disable (turn off) both Hibernation Mode and Seasonal Hibernation:



and the lantern will respond with a single long flash.

The Lantern will disable Hibernation Mode and enter Dusk-to-Dawn Mode.

Momentarily Wake Up from Hibernation Mode

Pressing the  button will wake up the lantern.

At which point the lantern will remain awake for a further 15 seconds to process other commands from the IR Controller. If no IR commands are received for a period of 15 seconds, the lantern will return to Hibernation mode.

Read Stored Hibernation Dates

By pressing the following key sequence the lantern will respond with the stored start and end dates for Hibernation:



Read Hibernation Mode Status

By pressing the following key sequence the lantern will respond with status of Hibernation mode.



Where:

- A single long flash = hibernation mode is Enabled
- Two quick flashes = hibernation mode is Disabled.

User Case Example: Configuring the lantern for Hibernation

In this example, we want the lantern to hibernate each year from Dec 10th, through to February 15th, and the lantern is located inside a storage warehouse.

The required key sequence is:

Command	IR Controller Key Press
Store the Hibernation Date Range	<p>A sequence of eleven circular buttons: red 'L', red 'I', black '1', black '0', black '1', black '2', black '1', black '5', black '0', black '2', and red 'T/C'.</p>
Enable Hibernation	<p>A sequence of four circular buttons: red 'L', red 'I', black '1', and red 'T/C'.</p>



Storage Mode (Advanced users)

For situations where the lantern is put into storage but with access to daylight, the IR Remote control can be used to configure the lantern into Storage Mode.

This mode manually forces the lantern to turn off, but with access to daylight it will still charge battery pack. However the lantern will not keep track of the date.

In Storage Mode, the GPS is disabled however the lantern will still respond to IR commands.

The lantern will automatically enter Storage Mode, if it is hibernating and it has not detected any light for 20 hours.

Enter Storage Mode

By pressing the following key sequence the lantern will enter Storage Mode:



The lantern will leave storage mode when exposed to daylight or if the power switch is turned OFF and ON again.

Set Operation Mode

There are three distinct lantern operational modes (always on, standby & Dust to Dawn) which can be set with the following key sequence



Always on



Standby Mode



Dusk to dawn

where

- *Always on* ignores the day light sensor. The light sensor is disabled, however if 20 continuous hours of darkness is detected, the lantern will enable Storage mode.
- *Standby* only disables the light with no additional power saving measures. (GPS is on)
- *Dusk to Dawn* the lantern turns on when darkness has been detected by the light sensor

Optional GSM Monitoring AV-C410-ILAB Model

The AV-C410-ILAB model may also be fitted with GSM Cell-Phone Monitoring – enabling users to access real-time diagnostics data and change light settings via cell-phone. The system can also be configured to send out alarm SMS text messages to designated cellular telephone numbers. Users can also have alarms and reports sent to designated email addresses.

Please contact Avlite for further information and instructions.



Figure 5. GSM enabled AV-C410-ILAB Model



Maintenance & Servicing

Designed to be almost maintenance-free, the AV-C310-ILA and AV-C410-ILAB require minimal attention, though the following maintenance and servicing information is provided to help ensure the life of your Avlite Systems product.

1. **Cleaning Solar Panels-** occasional cleaning of the solar panels may be required. Using a cloth and warm soapy water, wipe off any foreign matter before rinsing the panels with fresh water.
2. **Battery Check-** inspection of batteries should be performed every three years (minimum) to ensure that the charger, battery and ancillary electronics are functioning correctly. Using a voltage meter, check that the battery voltage is at least 12 volts under 100MA load, and ensure all terminals are clear of foreign matter.
3. **O-Ring Check-** inspect the condition of the o-ring for damage, wear or if it is brittle, and replace if necessary. The o-ring should be a rubber texture to ensure a complete and even seal.

Replacing the battery

The AV-C310-ILA and AV-C410-ILAB have an internal battery compartment, which provides the user with the ability to change the battery after years of operation.

1. Remove the four socket-head screws on the top lens assembly and separate the lens assembly from the body/base section.
2. Remove 2 x M4 cap screws & washers from the top of the chassis.
3. Separate the light head and battery via the 4Pin connector.
4. Lift the upper battery bracket out of the chassis.
5. Remove the old battery from the chassis.
6. Contact Avlite if you require a battery.
7. Discard old battery in a safe manner.
8. Reconnect the new battery.
9. Place battery back inside light body, and position the upper battery bracket in the top of the chassis.
10. Secure using 2 x M4 cap screws & washers.
11. Feed all wiring back inside light body, and make sure the o-ring is properly placed at the top of the light body.
12. Place the top lens assembly back onto the light body and replace 4 socket head screws. Half tighten all 4 socket head screws, and then fully tighten each socket head screw to ensure an even seal.
Recommended torque settings for Fitment of Light Heads to Solar Base units using the 4 Hex Bolts supplied. It is recommended that the bolts for holding the light heads to the Solar Base units have a torque setting applied of 3Nm for a satisfactory seal.
Applying a higher Torque setting is not recommended and may void warranty. If in doubt, please contact your local Avlite representative.
13. To test place dark cover (towel or jacket) on top of light for a minimum 30 seconds to activate the light.

***Care must be taken to observe the polarity of each wire before they are connected.
To ensure waterproofing of the unit, make sure that there is an even seal.***



Long term battery storage

If the light is to be placed in storage for an extended period please follow the below information.

The Sealed Lead Acid batteries inside the lights must always be stored in a fully charged state.

Always make sure the ON/OFF switch is in the OFF position.

All batteries will discharge over time and the rate of discharge is dependent on temperature.

If the light is being stored in temperatures greater than 40°C the battery will discharge faster.

Please check battery regularly and recharge if necessary,

Either/

Re-connect the light-head and battery and place unit in the sun for 2-4 days

Or/

Re-connect light-head and battery and place in front of a halogen lamp for 1-3 days. (Do not place the halogen light too close to the solar panel or the panel may be overheated)

Solar panel replacement

The light is built around an internal aluminium chassis. The solar panels can be user-replaced in the unlikely event that one is broken or damaged during the product's life.

Follow the steps below or contact support@sealite.com for more details.



1. Remove 4 x M6 x 20 socket head cap screws (SHCS) and 4 x M6 nylon washers and disconnect the light head from the chassis
2. Remove the 2 x M4 x 20 socket head cap screws (SHCS), 2 x M4 spring washers and 2 x M4 penny washers. Remove the upper battery bracket containing regulator
3. Disconnect the battery

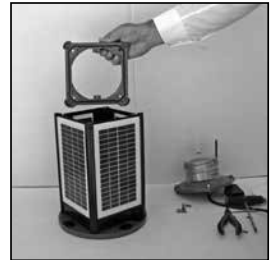

4. Remove 4 x M6-35mm long socket head cap screws, to remove the top casting from the chassis.

Note:

Be careful not to damage the o-rings on each of these screws. If replacements are required please use standard 6x1.0mm o-ring.



5. Slide the rubber corner out of the chassis, it may be necessary to lubricate the edges of the solar panels with grease or oil based lubricant if this is difficult to remove.
6. Unscrew the affected panel wires from the regulator and remove the solar panel from the chassis.

7. Clean any silicon off the chassis from the solar panel junction box hole and add a new seal to ensure the solar panel is watertight when assembled.

8. Repeat the process in the reverse order to replace a new panel.

Note:

Make sure the O-rings on the top casting and 4 x M6-35mm long socket head cap screws are coated in silicon grease before re-assembling.

9. Recommended torque settings for Fitment of Light Heads to Solar Base units using the 4 Hex Bolts supplied. It is recommended that the bolts for holding the light heads to the Solar Base units have a torque setting applied of 3Nm for a satisfactory seal.

Applying a higher Torque setting is not recommended and may void warranty. If in doubt, please contact your local Avlite representative.



The replacement of a solar panel should only be performed by a confident technician.

Avlite cannot guarantee the chassis will remain waterproof, if it not performed by Avlite staff.

To test for any leaks remove the gore vent and pressurise the assembled Light to 1.5psi.

How to change the regulator

1. Remove the 4 x M6 x 20 socket head cap screws (SHCS) and 4 x M6 nylon washers, then disconnect the light head from the chassis.
2. Remove the 2 x M4 x 20 SHCS, 2 x M4 spring washers and 2 x M4 penny washers then remove the upper battery bracket containing the regulator.
3. Disconnect the battery.
4. Take note of the wire colours and location in the regulator.
5. Disconnect the wires from the regulator.
6. Remove the 2 x M4 CSSK screws, 2 x M4 nylock nuts and 2 x M4 penny washers that retain the regulator to the top battery bracket and remove the regulator.
7. Fit the new regulator using the 2 x M4 CSSK screws, 2 x M4 penny washers and 2 x M4 nylock nuts.
8. Connect the solar positive wires to the solar + points on the regulator.
9. Connect the solar negative wires to the solar – points on the regulator.
10. Connect the battery positive wires to the Battery + point on the regulator.
11. Connect the battery negative wire to the battery – point on the regulator.
12. Reconnect the battery.
13. Refit the battery top bracket into the solar unit using the 2 x M4 x 20 SHCS.
14. Ensure the top O-ring is sitting correctly into the top casting. Refit the light head and tighten the M6 x 20 SHCS with the 4 x M6 nylon washers evenly. **DO NOT OVERTIGHTEN.**

Recommended torque settings for Fitment of Light Heads to Solar Base units using the 4 Hex Bolts supplied. It is recommended that the bolts for holding the light heads to the Solar Base units have a torque setting applied of 3Nm for a satisfactory seal.

Applying a higher Torque setting is not recommended and may void warranty. If in doubt, please contact your local Avlite representative.



Use the label to ensure correct location of wires during assembly



SL10 AMP Regulator shown when correctly fitted

Trouble Shooting

Problem	Remedy
Light will not activate.	<ul style="list-style-type: none"> • Ensure light is in darkness. • Wait at least 60 seconds for the program to initialise in darkness. • Ensure switch setting is on a valid code (not unused flash code). • Ensure battery terminals are properly connected. • Ensure battery voltage is above 12volts. • Check the Status LED's on the base of the PCB to determine what type of fault the light is activating.
Flash Codes will not change.	<ul style="list-style-type: none"> • Turn rotary switches several times to ensure contacts are clear.
Light will not operate for the entire night.	<ul style="list-style-type: none"> • Expose light to direct sunlight and monitor operation for several days. <i>Avlite products typically require 2.5 hours of direct sunlight per day to retain full autonomy. From a discharged state, the light may require several days of operational conditions to 'cycle' up to full autonomy.</i> • Reducing the light output intensity or duty cycle (flash code) will reduce current draw on the battery. • Ensure solar module is clean and not covered by shading during the day.

All AV-C310-ILA and AV-C410-ILAB Lights are fitted with two Indicator LED's. These are positioned on the edge of the board, near the Flash Code Rotary Switches. Use the table below to help determine operational status.

Yellow Status LED	Condition
Off	Daylight, Standby
Quick Flashing	Day to Night transition
2 Quick Flashes	Night Operation, Not Synchronized
1 Quick Flash	Night Operation, Sync in Progress
Slow Flashing	Night Operation, Synchronized

Red Status LED	Condition
Steady	Flat Battery cutoff is in effect (Below 10.0V)
Slow	High Voltage (Above 13.5V)
Off	Optimal Voltage (12.5V to 13.5V)
1 Quick	Ok Voltage (12.0V to 12.5V)
2 Quick	Low Voltage (11.5V to 12.0V)
3 Quick	Poor Voltage (10.0V to 11.5V)
4 Quick	Flat Voltage (Below 10.0V)



AV-SB-10 Solar Booster

The AV-SB-10 Solar Booster can be connected to AV-C410-ILAB light to provide additional solar collection to charge the battery. The Solar Booster can be used in areas of reduced sunlight to help ensure optimum battery charge or where longer periods of high intensity mode is required.

The solar panel is connected to the light via the external charge port and the panel is mounted at an angle to maximise solar collection during daylight hours.

The solar booster will provide up to 0.5Ah of additional charge into the battery.

In areas of high solar conditions, this may allow the fixture to operate in a high-intensity L-861 output setting for up to 11hrs per night.

In lower solar regions, fitting the solar booster may widen the operating latitudes where the standard AV-C410-ILAB may not be sufficient.

For detailed solar profiling of your region please contact Avlite Systems.

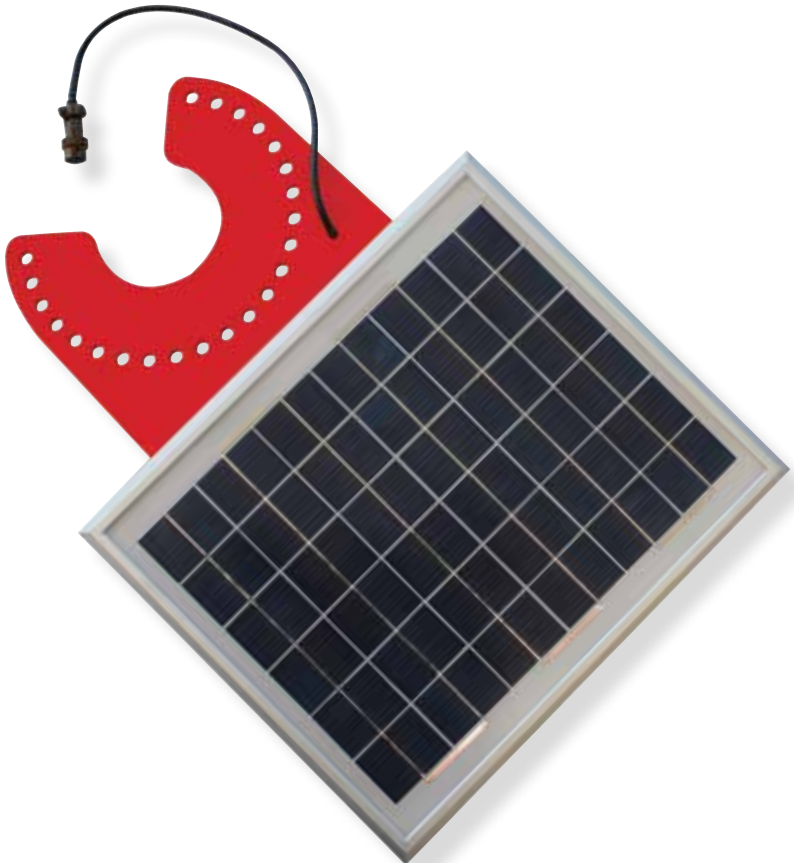

SPECIFICATIONS* *

AV-SB-10

Electrical Characteristics

Voltage (v)	12
Amperage (mA)	580
Temperature Range	-40 to 80°C

Solar Characteristics

Solar Module Type	Multicrystalline
Output (watts)	10
Solar Module Efficiency (%)	14
Charging Regulation	Microprocessor controlled

Physical Characteristics

Body Material	7-stage powder-coated aluminium
Mounting	4 hole bolt pattern on 200mm OD base
Height (mm/inches)	150 / 5 ⁷ / ₈
Width (mm/inches)	370 / 14 ¹ / ₂
Length (mm/inches)	560 / 22
Mass (kg/lbs)	3.2 / 7
Product Life Expectancy	Up to 12 years

Certifications

CE	EN61000-6-3:1997. EN61000-6-1:1997
Quality Assurance	ISO9001:2008
Waterproof	IP68

Intellectual Property

Trademarks

Solar Booster™ is a registered trademark of Avlite Systems
3 year warranty

Warranty *

- Specifications subject to change or variation without notice
- * Subject to standard terms and conditions



AV-SB-10 Solar Booster
shown with AV-C410-ILAB



Solar Booster Installation Procedure

Preferred Installation Location

For best light performance, ensure solar modules are not covered and are in clear view of the sky with no shadows.

Remove the AV-SB-10 from the box and remove all packaging.

Locate the AV-SB-10 Solar booster, in a position for best solar collection.

Remove the bolts from the existing installation. Fit the AV-SB-10 solar booster under the top mounting plate. Fit the bolts back through the light, mounting plate and AV-SB-10 Solar Booster. Tighten the bolts securely.

Important: To eliminate the possibility of electrical shorts please read this before connecting the AV-SB-10 Solar Booster to the light

Remove the Light head from the unit. Remove the fuse from the battery positive wire.

Connect the AV-SB-10 Solar Booster to the external charge port on the light.

Refit the fuse to the battery positive wire and refit the light head.

Cover the light head to ensure that light activates.

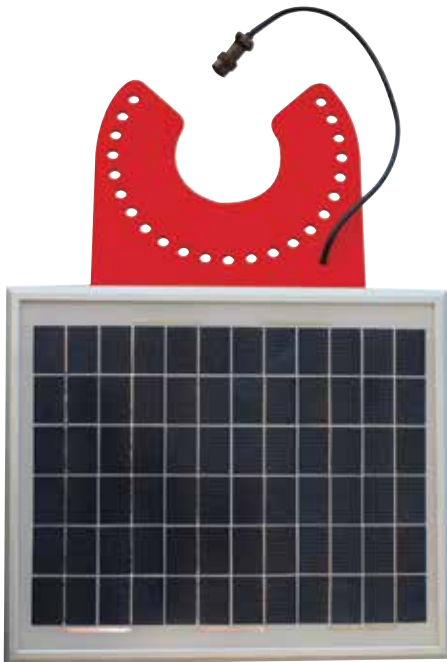

AV-SB-10 Solar Booster front view

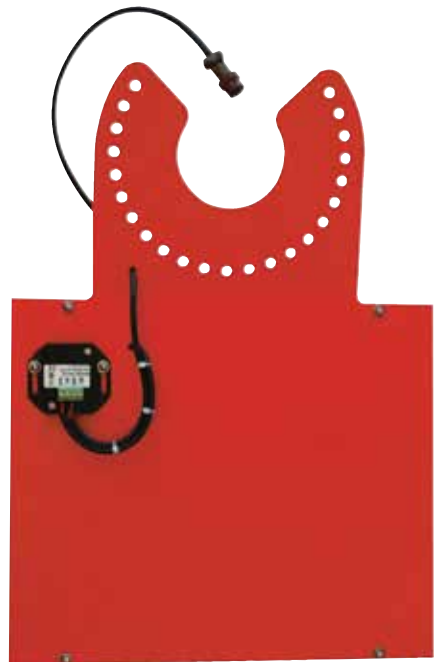

AV-SB-10 Solar Booster rear view



Avlite Light Warranty V1.2

Activating the Warranty

Upon purchase, the Avlite Systems warranty must be activated for recognition of future claims. To do this you need to register on-line. Please complete the Online Registration Form at:

www.avlite.com

Avlite Systems will repair or replace your lantern in the event of electronic failure for a period of up to three years from the date of purchase.

Avlite Systems will repair or replace any ancillary or accessory products in the event of failure for a period of up to one year from the date of purchase, as per the terms & conditions below.

The unit must be returned to Avlite freight prepaid.

Warranty Terms

1. Avlite Systems warrants that any Avlite aviation products fitted with telemetry equipment including but not limited to AIS, GSM, GPS or RF ("Telemetry Products") will be free from defective materials and workmanship under normal and intended use, subject to the conditions hereinafter set forth, for a period of twelve (12) months from the date of purchase by the original purchaser.
2. Avlite Systems warrants that any rotationally-moulded products ("Roto-Moulded Products") and accessory products ("Accessory Products") will be free from defective materials and workmanship under normal and intended use, subject to the conditions hereinafter set forth, for a period of twelve (12) months from the date of purchase by the original purchaser.
3. Avlite Systems warrants that any Avlite aviation products other than the Telemetry Products, Roto-Moulded Products and Accessory Products ("Avlite Products") will be free from defective materials and workmanship under normal and intended use, subject to the conditions hereinafter set forth, for a period of three (3) years from the date of purchase by the original purchaser.
4. Avlite Systems will repair or replace, at Avlite's sole discretion, any Telemetry Products, Roto-Moulded Products, Accessory Products or Avlite Products found to be defective in material and workmanship in the relevant warranty period so long as the Warranty Conditions (set out below) are satisfied.
5. If any Telemetry Products or Avlite Products are fitted with a rechargeable battery, Avlite Systems warrants the battery will be free from defect for a period of one (1) year when used within original manufacturer's specifications and instructions.

Warranty Conditions

This Warranty is subject to the following conditions and limitations;

1. The warranty is applicable to lanterns manufactured from 1/1/2009.
2. The warranty is void and inapplicable if:
 - a. the product has been used or handled other than in accordance with the instructions in the owner's manual and any other information or instructions provided to the customer by Avlite;
 - b. the product has been deliberately abused, or misused, damaged by accident or neglect or in being transported; or
 - c. the defect is due to the product being repaired or tampered with by anyone other than Avlite or authorised Avlite repair personnel.
3. The customer must give Avlite Systems notice of any defect with the product within 30 days of the customer becoming aware of the defect.
4. Rechargeable batteries have a limited number of charge cycles and may eventually need to be replaced. Typical battery replacement period is 3-4 years. Long term exposure to high temperatures will shorten the battery life. Batteries used or stored in a manner inconsistent with the manufacturer's specifications and instructions shall not be covered by this warranty.
5. No modifications to the original specifications determined by Avlite shall be made without written approval of Avlite Systems.
6. Avlite lights can be fitted with 3rd party power supplies and accessories but are covered by the 3rd



- party warranty terms and conditions.
7. The product must be packed and returned to Avlite Systems by the customer at his or her sole expense. Avlite Systems will pay return freight of its choice. A returned product must be accompanied by a written description of the defect and a photocopy of the original purchase receipt. This receipt must clearly list model and serial number, the date of purchase, the name and address of the purchaser and authorised dealer and the price paid by the purchaser. On receipt of the product, Avlite Systems will assess the product and advise the customer as to whether the claimed defect is covered by this warranty.
 8. Avlite Systems reserves the right to modify the design of any product without obligation to purchasers of previously manufactured products and to change the prices or specifications of any product without notice or obligation to any person.
 9. Input voltage shall not exceed those recommended for the product.
 10. Warranty does not cover damage caused by the incorrect replacement of battery in solar lantern models.
 11. This warranty does not cover any damage or defect caused to any product as a result of water flooding or any other acts of nature.
 12. There are no representations or warranties of any kind by Avlite or any other person who is an agent, employee, or other representative or affiliate of Avlite, express or implied, with respect to condition of performance of any product, their merchantability, or fitness for a particular purpose, or with respect to any other matter relating to any products.

Limitation of Liability

To the extent permitted by acts and regulations applicable in the country of manufacture, the liability of Avlite Systems under this Warranty will be, at the option of Avlite Systems, limited to either the replacement or repair of any defective product covered by this Warranty. Avlite Systems will not be liable to Buyer for consequential damages resulting from any defect or deficiencies in accepted items.

Limited to Original Purchaser

This Warranty is for the sole benefit of the original purchaser of the covered product and shall not extend to any subsequent purchaser of the product.

Miscellaneous

Apart from the specific warranties provided under this warranty, all other express or implied warranties relating to the above product is hereby excluded to the fullest extent allowable under law. The warranty does not extend to any lost profits, loss of good will or any indirect, incidental or consequential costs or damages or losses incurred by the purchaser as a result of any defect with the covered product.

Warrantor

Avlite Systems has authorised distribution in many countries of the world. In each country, the authorised importing distributor has accepted the responsibility for warranty of products sold by distributor. Warranty service should normally be obtained from the importing distributor from whom you purchased your product. In the event of service required beyond the capability of the importer, Avlite Systems will fulfil the conditions of the warranty. Such product must be returned at the owner's expense to the Avlite Systems factory, together with a photocopy of the bill of sale for that product, a detailed description of the problem, and any information necessary for return shipment.

Other Avlite Products Available



Solar Aviation Lighting



Helipad Lighting



Obstruction Lighting



**Airfield Markers
& Accessories**

Typical Applications

- Temporary & permanent airfield lighting
- Remote, emergency & defence airfield lighting
- Barricade, hazard & perimeter lighting
 - Helipad lighting
- Obstruction lighting

For a complete list of product compliances including ICAO & FAA, please contact Avlite today



**Portable Airfield Lighting
System**



Head Office

Avlite Systems
11 Industrial Drive
Somerville, Vic 3912
Australia

Tel: +61 (0)3 5977 6128
Fax: +61 (0)3 5977 6124

Email: info@avlite.com
Internet: www.avlite.com