

Avlite[®]
www.avlite.com



AV-70

Solar Aviation Light

ICAO, FAA L861T and CASA

INSTALLATION & SERVICE MANUAL

V6.0



Version No.	Description	Date	Reviewed	Approved	Design
6.0	AV-426 Manual Launch	June 2019	P. Naidu	W. Evans	M. Sugars

Table of Contents

1.0 Introduction	4
2.0 Technology.....	5
3.0 AV-70 Models L861, ICAO	6
3.1 AV-70 - Data Sheet	8
4.0 Installation.....	10
4.1 Selecting Power Intensity	12
4.2 Selecting a Flash Code - Rotary Switch A and B (AV-70 and AV-70-HI).....	13
4.3 Flash Codes	13
4.4 Installing the Light Assembly	18
4.5 Manual Light Activation via Momentary Button	23
5.0 Avlite Radio Controller	24
5.1 Assembly and Installation of Radio Controller	25
5.2 Radio Controller Menu.....	26
5.3 Using the Radio Control to Activate the Airfield Lighting System (ALS).....	28
6.0 Maintenance and Servicing	30
7.0 Troubleshooting.....	32



1.0 Introduction

Congratulations! By choosing to purchase an Avlite light, you have become the owner of one of the most advanced solar LED airfield lights in the world.

Avlite Systems draws on more than 25 years experience in the design and manufacture of navigation aids, and particular care has been taken to ensure your light gives years of trouble free service.

As a commitment to producing the highest quality products for our customers, Avlite has been independently certified as complying with the requirements of ISO 9001:2015 quality management system.

By taking a few moments to browse through this booklet, you will become familiar with the versatility of your light, and be able to maximise its operating function.

Please remember to complete the Avlite warranty registration at www.avlite.com.

2.0 Technology

Avlite Systems is a world-class solar lighting systems manufacturer with a proven reputation for rapid, innovative, and agile technology solutions designed specifically for defence, government, civil and humanitarian aid operations in the most remote, toughest environments.

Electronics

Avlite employs leading in-house electronic engineers in the design and development of software and related circuitry. All individual electronic components are sourced directly by Avlite procurement staff ensuring that only the highest quality components are used in our products.

LED Technology

All Avlite lights use the latest advancements in LED (Light Emitting Diode) technology as a light source. The major advantage of LED's over traditional light sources is well established in that they typically have an operational life in excess of 100,000 hours, resulting in substantial savings to maintenance and servicing costs.

Precision Construction

Commitment to investing in the design and construction of injection-moulded parts including optic lenses, light bases and a range of other components ensures that all Avlite products are of a consistent and superior quality.

Optical Performance

Avlite manufactures a range of aviation LED lenses moulded from multi-cavity dies. The company has superior in-house lens manufacturing capabilities to support outstanding optical performance.

Award-winning, Patented Technology

Several United States and Australian patent registrations are held on Avlite's range of innovative designs, with other regional patents pending in Canada, United Kingdom and Europe.

Operating Principle

The solar module of the light converts sunlight to an electrical current that is used to charge the battery. The battery provides power to operate the light at night. For optimum solar charge performance it is recommended that the unit is orientated with the solar panels facing East-West.

The flasher unit has very low current requirements. A microprocessor drives an array of ultra bright LED's through a DC/DC converter, which enables the LED's to operate within the manufacturer's specifications. The battery is protected from over-charging within the circuit to ensure maximum battery life.

On darkness, the microprocessor will initiate a program check and after approximately 1 minute will turn on.



3.0 AV-70 Models

Standard, HI, L861T and RF

The Avlite AV-70 solar airfield light is exceptional in its unique ability to 'track the sun', operating reliably in low sunlight conditions. Made from tough, durable polycarbonate and using the latest high-intensity LED's, the AV-70 light boasts dual high-performance solar modules incorporated into Avlite's world-first Solar Collection Lens.

The solar modules of the light convert sunlight to an electrical current that is used to charge the battery. The battery provides power to operate the light at night.

The LED driving circuitry has very low current requirements. A microprocessor drives an LED through a DC/DC converter, which enables the LED to operate within the manufacturer's specifications. The battery is protected from over-charging within the circuit to ensure maximum battery life.

The AV-70-HI is a high intensity version of the popular AV-70 and is ideal for use in high sunlight areas that receive a minimum of 3.5 hours of sun per day.

The AV-70-L861T is Avlite's Taxiway Light which complies with the Photometric and Chromacity requirements of FAA Advisory Circular AC 150/5345-46E, Type L-861T

The AV-70-RF solar aviation light is a radio controlled version of the popular AV-70 which can be used in conjunction with a PALC or simple handheld controller. Users can wirelessly control ON/ OFF functions, adjust light intensities, and switch between visual and IR (tactical) operational modes.

Multiple Radio Controllers can be used to operate the lights at the same time.

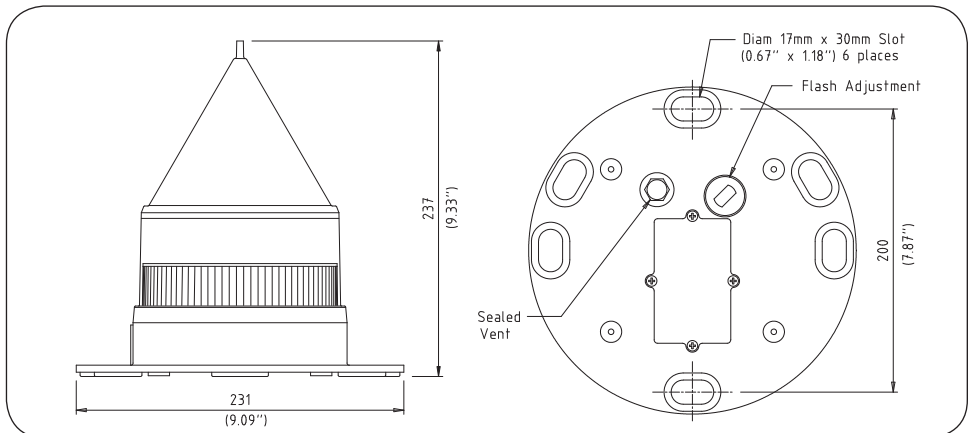
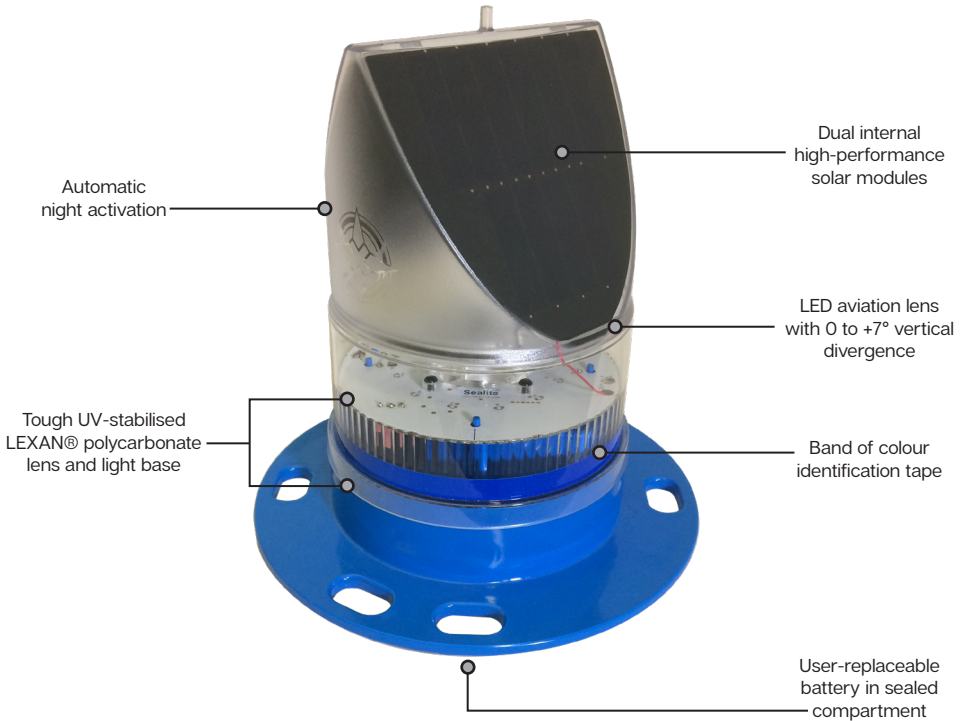



3.1 AV-70 - Data Sheet

	AV-70	AV-70-HI	AV-70-RF
Light Characteristics			
Light Source	LED		
Available colours	Red, Green, White, Yellow, Blue		
Horizontal Output (degrees)	360		
Vertical Divergence (degrees)	0 to +7		
Peak Intensity Steady On (cd)	Red - 12 Green - 11 White - 13.9 Yellow - 8.6 Blue - 4.3	Red - 17.4 Green - 16 White - 20.1 Yellow - 13 Blue - 7.8	Red - 12 Green - 11 White - 13.9 Yellow - 8.6 Blue - 4.3
Intensity Adjustments	3 Steps - Low, Med, High †		
LED Life Expectancy (hours)	>100,000		
Electrical Characteristics			
Operating Voltage (V)	3.6		
Temperature Range	-40 to 80°C		
Solar Characteristics			
Solar Module Type	Monocrystalline		
Output (watts)	2.8 (2 x 1.4 watt)		
Solar Module Efficiency (%)	21		
Charging Regulation	Microprocessor controlled		
Power Supply			
Battery Type	High grade NiMH – Environmentally friendly		
Battery Capacity (Ah)	8.6 as stated (16AH available)	17.2	8.6 as stated (16AH available)
Nominal Voltage (V)	3.6		
Autonomy (nights)	Steady-on: >14	Steady-on: >19	Steady-on: >14
Radio Control			
Frequency	-	-	2.4GHz ISM Band
Range	-	-	Up to 1.4km relayed
Expandability	-	-	AvMesh®
Compliance	-	-	FCC / CE
Physical Characteristics			
Body Material	LEXAN® Polycarbonate – UV stabilized		
Lens Material	LEXAN® Polycarbonate – UV stabilized		
Lens Diameter (mm/inches)	140 / 5½		
Lens Design	Single LED optic		
Mounting	6 x 17mm holes on 200mm PCD		
Height (mm/inches)	240 / 9½		
Width (mm/inches)	231 / 7¼		
Mass (kg/lbs)	1.4 / 3¼	1.6 / 3¼	1.4 / 3¼
Product Life Expectancy	Up to 12 years		

Environmental Factors			
Humidity	0 to 100%, MIL-STD-810F		
Icing	3.41kg per square cm / 48.5lbs per square inch		
Wind Speed	Up to 160kph		
Shock	MIL-STD-202G, Test Condition G, Method 213B		
Vibration	MIL-STD202G, Test Condition B, Method 204		
Certifications			
CE	EN61000-6-3:2007 EN61000-6-1:2007		
Quality Assurance	ISO9001:2015		
Waterproof	IP68		
Compliance			
ICAO	Annex. 14 Volume 1 'Aerodrome Design and Operations', Taxiway Edge		
FAA	L861T		
	Barricade AC 150/5370-2F		
	LED Colour Standard (Engineering Brief No. 67D)		
Other regulations	-	CASA MOS Part 139, Volume 2, 2016, Section 9.13.15	-
	DGAC (Mexico)		
Intellectual Property			
Trademarks	AVLITE® is a registered trademark of Avlite Systems Patents Pending		
Warranty *	3 year warranty		
Options Available	<ul style="list-style-type: none"> • Manual Operation • Radio Controlled • Avlite Pilot Activated Lighting Control <ul style="list-style-type: none"> • IR LEDs • External ON/OFF Switch • External Battery Charging Port <ul style="list-style-type: none"> • Solar Booster™ 		

†* Specifications subject to change or variation without notice. Subject to standard terms and conditions.



4.0 Installation

Charging the Battery

New lights should be left in the sun for 1-2 days to ensure battery is charged before placing in service. Please note, light will re-charge even when toggle switch is turned to 'OFF' position.

Preferred Installation Location

For best light performance, ensure solar modules are not covered and are in clear view of the sky with no shadows.

Tools required for assembly & installation:-

- Large flat blade screwdriver (to suit "Flash Adjustment" Plug)
- Hammer or Sledge Hammer
- 6mm Allen Key

Unpacking Instructions

Unpack all hardware and verify container contents.

Please contact your Avlite office if there is any hardware missing.

Initial Inspection

Inspect all hardware for damage. If there is any damage, please contact your Avlite Office. Retain original packing material for possible future use in shipping the AV-70.

Light Operation - AV-70 and AV-70-HI

Light is activated by ON/OFF Switch. Intensity and flash settings need to be set prior to installation.

1. Remove the marked flash adjustment bung (refer to image on page 7) from the base of the light using a flat blade screwdriver and set internal toggle switch to 'ON' or flick the External Switch to 'ON'.
2. A sealed vent on the base allows air transfer without moisture intake, and should not be disturbed.
3. The power and range settings are factory set by Avlite to comply with any Regularity or Customer requirements.
4. Set rotary switches to the required flash code (see '4.2 Selecting a Flash Code - Rotary Switches A and B (AV-70 and AV-70-HI)' section of this manual).
5. Replace flash adjustment bung.
6. To test place dark cover (towel or jacket) on top of light to activate sensor, light will come on within one minute.
7. Ensure that the unit is bolted to an even, flat surface.

Light Operation and Configuration - AV-70-RF

- **NOTE:** Before activating the lights, the lights must be layed out on the runway in the location they will be installed.
 - **NOTE:** RF lights should always be installed on mounting plates and stakes. Avlite does not recommend installation on rubber tiles.
1. Use a large flat-blade screwdriver to remove the Flash Adjustment Plug from the base of the light (see Figure 1). A sealed vent on the base allows air transfer without moisture intake and should not be disturbed.
 2. Setting the Light Group: Adjust Rotary Switches, A & B. Determine, to which group, each individual light belongs. E.g., taxiway edge lights = 0, runway edge lights = 1, obstruction lights = 2, threshold lights = 3, etc...
Adjust Rotary Switch A to the appropriate light group. E.g. 0, 1, or 2
 3. Set the toggle switch to the “ON” position. This will activate the AV-70-RF.
 4. To test operation of the light, the Radio Controller will need to be used (see “Using the Radio Control to activate the ALS System” section of manual for information).
 5. Replace the Flash Adjustment Plug.
 6. Bolt the light into location.

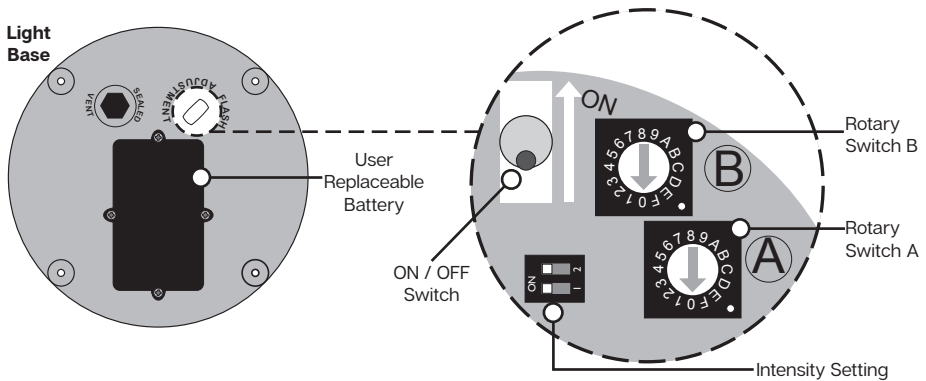



4.1 Selecting an Intensity/Power Setting - AV-70 and AV-70-HI

Intensity/power settings on Avlite lanterns operate via DIP switches, located near the rotary switches on the flasher unit. The intensity/power settings may be used to reduce the power consumption and intensity of the lantern. Setting the lantern to 25% intensity will reduce the power consumption to 25% of the normal 100% setting and the range by 25%. This setting may be used to adjust the current draw of the light to local sunlight conditions.

The following diagrams indicate intensity/power settings:-

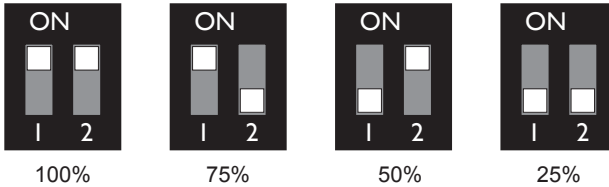

Intensity Setting	Power: mA / hour	
	AV-70	AV-70-HI
100%	34-36	54-56
75%	26-27	40-42
50%	17-18	27-28
25%	8-9	13-14

Power Consumption Calculator

Night Hours (use 13.7 if unknown)	Power mA/hour	Duty Cycle (e.g. 20% = 0.2)	Total power used per night (mA)
	X	X	=

Total power used per night (mAh)	Solar Panel Charge (mA)	Number of full sunlight hours required to break even (the amount of time it will take for the solar panel to replace what the light took out overnight)
	/ 279	=

If the number of Full Sunlight hours is less than 2.5-3.0 hours, please consider reducing the intensity (Power) or reducing the Duty Cycle.

4.2 Selecting a Flash Code - Rotary Switches A and B (AV-70 and AV-70-HI)

All lights have 2 rotary switches marked A and B on the flasher unit. Turning the small arrows to the appropriate number or letter will set the code (see '4.3 Flash Codes' section, of this manual). The unit may take up to one minute to activate a new flash code. A comprehensive list of available flash codes is listed on pages in the 'Flash Codes' section of this manual.

Example:

SWITCH		FLASH CODE	ON	OFF
A	B			
A	0	FL 3 S	0.3	2.7

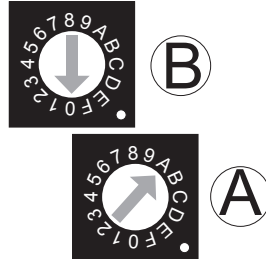

4.3 Flash Codes

AVLITE® code reference is listed by number of flashes

For the latest version of this document visit www.avlite.com, or email support@avlite.com

Symbols

FL	Flash followed by number Eg. FL 1 S, one flash every second
F	Fixed
Q	Quick flash
VQ	Very quick flash
OC	Occulting; greater period on than off
ISO	Isophase; equal period on and off
LFL	Long flash long
MO	Morse code () contains letter

For example, VQ (6) + LFL 10 S means 6 very quick flashes followed by a long flash, during a 10-second interval.

The amount of power your light draws through the night depends on the duty cycle, i.e. the amount of time on as a proportion to the timing cycle. For example, 0.5 seconds on and 4.5 seconds off equals a 10% duty cycle.

It is best to operate at the lowest duty cycle appropriate to the actual needs of the application.

Please note, Avlite models will retain full autonomy in normal operating conditions with duty cycles up to approximately 30%. In applications whereby duty cycles exceed this limit, a reduction in light intensity is recommended. Please contact a Avlite consultant if assistance is required.



SWITCH		FLASH CODE	ON	OFF
A	B			
0	0	F (Steady light)		
D	3	VQ 0.5 S	0.2	0.3
E	3	VQ 0.6 S	0.2	0.4
F	3	VQ 0.6 S	0.3	0.3
7	3	Q1 S	0.2	0.8
8	3	Q1 S	0.3	0.7
9	3	Q1 S	0.4	0.6
A	3	Q1 S	0.5	0.5
8	4	Q1 S	0.8	0.2
B	3	Q1.2 S	0.3	0.9
9	4	Q1.2 S	0.5	0.7
C	3	Q1.2 S	0.6	0.6
F	4	FL 1.5 S	0.2	1.3
1	0	FL 1.5 S	0.3	1.2
0	5	FL 1.5 S	0.4	1.1
0	4	FL 1.5 S	0.5	1.0
2	0	FL 2 S	0.2	1.8
3	0	FL 2 S	0.3	1.7
4	0	FL 2 S	0.4	1.6
5	0	FL 2 S	0.5	1.5
6	0	FL 2 S	0.7	1.3
7	0	FL 2 S	0.8	1.2
1	2	ISO 2 S	1.0	1.0
8	0	FL 2.5 S	0.3	2.2
9	0	FL 2.5 S	0.5	2.0
D	6	FL 2.5 S	1.0	1.5
1	5	FL 3 S	0.2	2.8
A	0	FL 3 S	0.3	2.7
2	5	FL 3 S	0.4	2.6
B	0	FL 3 S	0.5	2.5
3	5	FL 3 S	0.6	2.4
C	0	FL 3 S	0.7	2.3
D	0	FL 3 S	1.0	2.0
2	2	ISO 3 S	1.5	1.5
5	4	OC 3 S	2.0	1.0
E	2	OC 3 S	2.5	0.5
4	6	OC 3.5 S	2.5	1.0
4	5	FL 4 S	0.2	3.8
5	5	FL 4 S	0.3	3.7
E	0	FL 4 S	0.4	3.6
F	0	FL 4 S	0.5	3.5
6	5	FL 4 S	0.6	3.4
0	1	FL 4 S	0.8	3.2
1	1	FL 4 S	1.0	3.0
2	1	FL 4 S	1.5	2.5
3	2	ISO 4 S	2.0	2.0
3	6	OC 4 S	2.5	1.5
F	2	OC 4 S	3.0	1.0
3	1	FL 4.3 S	1.3	3.0
8	5	FL 5 S	0.2	4.8
4	1	FL 5 S	0.3	4.7
5	1	FL 5 S	0.5	4.5
9	5	FL 5 S	0.9	4.1
6	1	FL 5 S	1.0	4.0

SWITCH		FLASH CODE	ON	OFF
A	B			
7	1	FL 5 S	1.5	3.5
4	2	ISO 5 S	2.5	2.5
8	2	LFL 5 S	2.0	3.0
0	3	OC 5 S	3.0	2.0
1	3	OC 5 S	4.0	1.0
2	3	OC 5 S	4.5	0.5
C	6	FL 6 S	0.2	5.8
B	5	FL 6 S	0.3	5.7
C	5	FL 6 S	0.4	5.6
8	1	FL 6 S	0.5	5.5
9	1	FL 6 S	0.6	5.4
A	1	FL 6 S	1.0	5.0
7	5	FL 6 S	1.2	4.8
B	1	FL 6 S	1.5	4.5
5	2	ISO 6 S	3.0	3.0
9	2	LFL 6 S	2.0	4.0
6	4	OC 6 S	4.0	2.0
3	3	OC 6 S	4.5	1.5
4	3	OC 6 S	5.0	1.0
A	4	FL 7 S	1.0	6.0
9	6	FL 7 S	2.0	5.0
5	6	OC 7 S	4.5	2.5
D	5	FL 7.5 S	0.5	7.0
C	1	FL 7.5 S	0.8	6.7
E	5	FL 8 S	0.5	7.5
B	4	FL 8 S	1.0	7.0
6	2	ISO 8 S	4.0	4.0
A	2	LFL 8 S	2.0	6.0
6	6	OC 8 S	5.0	3.0
B	2	LFL 8 S	3.0	5.0
F	5	FL 9 S	0.9	8.1
C	4	FL 9 S	1.0	8.0
7	6	OC 9 S	6.0	3.0
0	6	FL 10 S	0.2	9.8
1	6	FL 10 S	0.3	9.7
D	1	FL 10 S	0.5	9.5
2	6	FL 10 S	0.8	9.2
E	1	FL 10 S	1.0	9.0
1	4	FL 10 S	1.5	8.5
C	2	LFL 10 S	2.0	8.0
D	2	LFL 10 S	3.0	7.0
7	2	ISO 10 S	5.0	5.0
2	4	LFL 10 S	4.0	6.0
8	6	OC 10 S	6.0	4.0
5	3	OC 10 S	7.0	3.0
6	3	OC 10 S	7.5	2.5
F	1	FL 12 S	1.2	10.8
D	4	FL 12 S	2.5	9.5
3	4	LFL 12 S	2.0	10.0
0	2	FL 15 S	1.0	14.0
4	4	LFL 15 S	4.0	11.0
7	4	OC 15 S	10	5.0
A	6	LFL 20 S	2.0	18.0
E	4	FL 26 S	1.0	25.0

SWITCH	FLASH CODE	ON	OFF	ON	OFF	
A	B					
0	A	FL (2) 4 S	0.5	1.0	0.5	2.0
E	B	VQ (2) 4 S	0.2	1.0	0.2	2.6
1	A	FL (2) 4.5 S	0.3	1.0	0.3	2.9
2	A	FL (2) 4.5 S	0.4	1.0	0.4	2.7
3	A	FL (2) 4.5 S	0.5	1.0	0.5	2.5
F	9	FL (2) 5 S	0.2	0.8	0.2	3.8
2	C	FL (2) 5 S	0.2	1.2	0.2	3.4
4	A	FL (2) 5 S	0.4	0.6	0.4	3.6
0	7	FL (2) 5 S	0.5	1.0	0.5	3.0
1	7	FL (2) 5 S	1.0	1.0	1.0	2.0
9	B	Q (2) 5 S	0.3	0.7	0.3	3.7
2	9	Q (2) 5 S	0.5	0.5	0.5	3.5
5	A	FL (2) 5.5 S	0.4	1.4	0.4	3.3
7	8	FL (2) 6 S	0.3	0.6	1.0	4.1
A	A	FL (2) 6 S	0.3	0.9	0.3	4.5
6	A	FL (2) 6 S	0.3	1.0	0.3	4.4
7	A	FL (2) 6 S	0.4	1.0	0.4	4.2
9	9	FL (2) 6 S	0.5	1.0	0.5	4.0
2	8	FL (2) 6 S	0.8	1.2	0.8	3.2
3	7	FL (2) 6 S	1.0	1.0	1.0	3.0
3	9	Q (2) 6 S	0.3	0.7	0.3	4.7
A	9	FL (2) 7 S	1.0	1.0	1.0	4.0
7	B	FL (2) 8 S	0.4	0.6	2.0	5.0
8	A	FL (2) 8 S	0.4	1.0	0.4	6.2
4	7	FL (2) 8 S	0.5	1.0	0.5	6.0
8	8	FL (2) 8 S	0.8	1.2	2.4	3.6
5	7	FL (2) 8 S	1.0	1.0	1.0	5.0
4	C	OC (2) 8 S	3.0	2.0	1.0	2.0
5	C	OC (2) 8 S	5.0	1.0	1.0	1.0
F	B	VQ (2) 8 S	0.2	1.0	0.2	6.6
9	A	FL (2) 10 S	0.4	1.6	0.4	7.6
6	7	FL (2) 10 S	0.5	1.0	0.5	8.0
7	7	FL (2) 10 S	0.5	1.5	0.5	7.5
6	9	FL (2) 10 S	0.5	2.0	0.5	7.0
8	7	FL (2) 10 S	0.8	1.2	0.8	7.2
B	9	FL (2) 10 S	1.0	1.0	1.0	7.0
9	7	FL (2) 10 S	1.0	1.5	1.0	6.5
4	9	Q (2) 10 S	0.6	0.4	0.6	8.4
B	A	FL (2) 12 S	0.4	1.0	0.4	10.2
C	9	FL (2) 12 S	0.5	1.0	0.5	10.0
D	9	FL (2) 12 S	1.5	2.0	1.5	7.0
A	8	FL (2) 15 S	0.5	1.5	2.0	11.0
A	7	FL (2) 15 S	1.0	2.0	1.0	11.0
8	B	Q (2) 15 S	0.2	0.8	0.2	13.8
C	A	FL (2) 20 S	1.0	3.0	1.0	15.0
D	A	FL (2) 25 S	1.0	1.0	1.0	22.0

SWITCH	FLASH CODE	ON	OFF	ON	OFF	ON	OFF	
A	B							
7	9	Q (3) 5 S	0.5	0.5	0.5	0.5	2.5	
5	9	VQ (3) 5 S	0.2	0.3	0.2	0.3	3.8	
0	C	VQ (3) 5 S	0.3	0.2	0.3	0.2	3.7	
E	9	VQ (3) 5 S	0.3	0.3	0.3	0.3	3.5	
3	C	FL (3) 6 S	0.5	1.0	0.5	1.0	2.5	
2	B	FL (2+1) 6 S	0.3	0.4	0.3	1.2	0.3	3.5



SWITCH	FLASH CODE	ON	OFF	ON	OFF	ON	OFF
A	B						
A	B Q (3) 6 S	0.3	0.7	0.3	0.7	0.3	3.7
F	A FL (3) 8 S	0.5	1.0	0.5	1.0	0.5	4.5
O	B FL (3) 9 S	0.3	1.0	0.3	1.0	0.3	6.1
B	7 FL (3) 9 S	0.8	1.2	0.8	1.2	0.8	4.2
B	8 FL (3) 10 S	0.3	0.7	0.3	0.7	0.9	7.1
C	8 FL (3) 10 S	0.4	0.6	0.4	0.6	1.2	6.8
C	B FL (3) 10 S	0.5	0.5	0.5	0.5	0.5	7.5
C	7 FL (3) 10 S	0.5	1.5	0.5	1.5	0.5	5.5
D	B FL (3) 10 S	0.6	0.6	0.6	0.6	0.6	7.0
D	7 FL (3) 10 S	1.0	1.0	1.0	1.0	1.0	5.0
3	8 FL (2+1) 10 S	0.5	0.7	0.5	2.1	0.5	5.7
8	9 OC (3) 10 S	5.0	1.0	1.0	1.0	1.0	1.0
B	B Q (3) 10 S	0.3	0.7	0.3	0.7	0.3	7.7
D	8 FL (2 + 1) 10 S	0.5	0.5	0.5	0.5	1.5	6.5
1	B FL (3) 12 S	0.5	1.5	0.5	1.5	0.5	7.5
E	A FL (3) 12 S	0.5	2.0	0.5	2.0	0.5	6.5
E	7 FL (3) 12 S	0.8	1.2	0.8	1.2	0.8	7.2
B	6 FL (3) 12 S	1.0	1.0	1.0	3.0	1.0	5.0
4	8 FL (2+1) 12 S	0.8	1.2	0.8	2.4	0.8	6.0
5	8 FL (2+1) 12 S	1.0	1.0	1.0	4.0	1.0	4.0
1	8 FL (2+1) 13.5 S	1.0	1.0	1.0	4.0	1.0	5.5
F	7 FL (3) 15 S	0.3	1.7	0.3	1.7	0.3	10.7
9	D FL (3) 15 S	0.4	1.0	0.4	1.0	0.4	11.8
O	8 FL (3) 15 S	0.5	1.5	0.5	1.5	0.5	10.5
F	8 FL (2+1) 15 S	0.6	0.3	0.6	0.3	1.4	11.8
O	9 FL (2+1) 15 S	0.7	0.5	0.7	0.5	1.9	10.7
1	9 FL (2+1) 15 S	0.7	0.7	0.7	0.7	2.1	10.1
6	8 FL (2+1) 15 S	1.0	2.0	1.0	5.0	1.0	5.0
1	C VQ (3) 15 S	0.1	0.5	0.1	0.5	0.1	13.7
4	B FL (3) 20 S	0.5	3.0	0.5	3.0	0.5	12.5
3	B FL (3) 20 S	0.5	1.5	0.5	1.5	0.5	15.5
5	B FL (3) 20 S	0.8	1.2	0.8	1.2	0.8	15.2
6	B FL (3) 20 S	1.0	1.0	1.0	1.0	1.0	15.0

SWITCH	FLASH CODE	ON	OFF	ON	OFF	ON	OFF	ON	OFF
A	B								
B	F VQ (4) 4 S	0.3	0.3	0.3	0.3	0.3	0.3	0.3	2.3
B	D Q (4) 6 S	0.3	0.7	0.3	0.7	0.3	0.7	0.3	2.7
8	D Q (4) 6 S	0.4	0.6	0.4	0.6	0.4	0.6	0.4	2.6
1	D FL (4) 10 S	0.5	1.0	0.5	1.0	0.5	1.0	0.5	5.0
2	D FL (4) 10 S	0.8	1.2	0.8	1.2	0.8	1.2	0.8	3.2
F	E Q (4) 10 S	0.3	0.7	0.3	0.7	0.3	0.7	0.3	6.7
B	E FL (4) 12 S	0.3	1.7	0.3	1.7	0.3	1.7	0.3	5.7
4	F FL (4) 12 S	0.5	0.5	0.5	0.5	0.5	0.5	0.5	8.5
C	E FL (4) 12 S	0.5	1.5	0.5	1.5	0.5	1.5	0.5	5.5
3	D FL (4) 12 S	0.8	1.2	0.8	1.2	0.8	1.2	0.8	5.2
A	D Q (4) 12 S	0.3	0.7	0.3	0.7	0.3	0.7	0.3	8.7
4	D FL (4) 15 S	0.5	1.5	0.5	1.5	0.5	1.5	0.5	8.5
8	E FL (4) 15 S	1.0	1.0	1.0	1.0	1.0	1.0	1.0	8.0
7	D FL (4) 15 S	1.5	0.5	0.5	0.5	0.5	0.5	0.5	10.5
D	E FL (4) 16 S	0.5	1.5	0.5	1.5	0.5	1.5	0.5	9.5
C	D FL (4) 20 S	0.3	3.0	0.3	3.0	0.3	3.0	0.3	9.8
5	D FL (4) 20 S	0.5	1.5	0.5	1.5	0.5	1.5	0.5	13.5
0	D FL (4) 20 S	0.5	1.5	0.5	1.5	0.5	4.5	0.5	10.5
3	F FL (4) 20 S	1.5	1.5	1.5	1.5	1.5	1.5	1.5	9.5
0	F Q (4) 20 S	0.5	0.5	0.5	0.5	0.5	0.5	0.5	16.5
E	E Q (4) 28 S	0.5	0.5	0.5	0.5	0.5	0.5	0.5	24.5
6	F FL (4) 30 S	0.5	0.5	0.5	0.5	0.5	0.5	0.5	26.5

SWITCH	FLASH CODE	ON	OFF	ON	OFF	ON	OFF	ON	OFF	ON	OFF
A	B										
D	D Q (5) 7 S	0.3	0.7	0.3	0.7	0.3	0.7	0.3	0.7	0.3	0.7
E	D Q (5) 10 S	0.3	0.7	0.3	0.7	0.3	0.7	0.3	0.7	0.3	0.7
E	8 FL (5) 12 S	0.5	1.5	0.5	1.5	0.5	1.5	0.5	1.5	0.5	1.5
5	F FL (5) 20 S	0.5	0.5	0.5	0.5	0.5	0.5	0.5	0.5	0.5	0.5
9	F FL (5) 20 S	0.8	1.2	0.8	1.2	0.8	1.2	0.8	1.2	0.8	1.2
9	E FL (5) 20 S	1.0	1.0	1.0	1.0	1.0	1.0	1.0	1.0	1.0	1.0

SWITCH	FLASH CODE	ON	OFF	ON	OFF	ON	OFF	ON	OFF	ON	OFF	ON	OFF
A	B												
F	D Q (6) 10 S	0.3	0.7	0.3	0.7	0.3	0.7	0.3	0.7	0.3	0.7	0.3	0.7
A	F FL (6) 15 S	0.3	0.7	0.3	0.7	0.3	0.7	0.3	0.7	0.3	0.7	0.3	0.7
7	F FL (6) 15 S	0.5	1.0	0.5	1.0	0.5	1.0	0.5	1.0	0.5	1.0	0.5	1.0

SWITCH	FLASH CODE	ON	OFF	ON	OFF	ON	OFF	ON	OFF	ON	OFF	ON	OFF	ON	OFF
A	B														
6	E VQ (6) + LFL 10 S	0.2	0.3	0.2	0.3	0.2	0.3	0.2	0.3	0.2	0.3	0.2	0.3	0.2	0.3
7	E VQ (6) + LFL 10 S	0.3	0.3	0.3	0.3	0.3	0.3	0.3	0.3	0.3	0.3	0.3	0.3	0.3	0.3
2	F Q (6) + LFL 15 S	0.2	0.8	0.2	0.8	0.2	0.8	0.2	0.8	0.2	0.8	0.2	0.8	0.2	0.8
2	E Q (6) + LFL 15 S	0.3	0.7	0.3	0.7	0.3	0.7	0.3	0.7	0.3	0.7	0.3	0.7	0.3	0.7
3	E Q (6) + LFL 15 S	0.6	0.6	0.6	0.6	0.6	0.6	0.6	0.6	0.6	0.6	0.6	0.6	0.6	0.6
8	F VQ (6) + LFL 15 S	0.3	0.3	0.3	0.3	0.3	0.3	0.3	0.3	0.3	0.3	0.3	0.3	0.3	0.3

SWITCH	FLASH CODE	ON	OFF	ON	OFF	ON	OFF	ON	OFF	ON	OFF	ON	OFF	ON	OFF	ON	OFF
A	B																
4	E VQ (9) 10 S	0.2	0.3	0.2	0.3	0.2	0.3	0.2	0.3	0.2	0.3	0.2	0.3	0.2	0.3	0.2	0.3
5	E VQ (9) 10 S	0.3	0.3	0.3	0.3	0.3	0.3	0.3	0.3	0.3	0.3	0.3	0.3	0.3	0.3	0.3	0.3
1	F Q (9) 15 S	0.2	0.8	0.2	0.8	0.2	0.8	0.2	0.8	0.2	0.8	0.2	0.8	0.2	0.8	0.2	0.8
0	E Q (9) 15 S	0.3	0.7	0.3	0.7	0.3	0.7	0.3	0.7	0.3	0.7	0.3	0.7	0.3	0.7	0.3	0.7
1	E Q (9) 15 S	0.6	0.6	0.6	0.6	0.6	0.6	0.6	0.6	0.6	0.6	0.6	0.6	0.6	0.6	0.6	0.6

SWITCH	FLASH CODE	ON	OFF	ON	OFF	ON	OFF	ON	OFF	
A	B									
MORSE CODE () INDICATES LETTER										
7	8 MO (A) 6 S	0.3	0.6	1.0	4.1					
7	B MO (A) 8 S	0.4	0.6	2.0	5.0					
8	8 MO (A) 8 S	0.8	1.2	2.4	3.6					
B	8 MO (U) 10 S	0.3	0.7	0.3	0.7	0.9	7.1			
C	8 MO (U) 10 S	0.4	0.6	0.4	0.6	1.2	6.8			
D	8 MO (U) 10 S	0.5	0.5	0.5	0.5	1.5	6.5			
9	8 MO (A) 10 S	0.5	0.5	1.5	7.5					
8	9 MO (D) 10 S	5.0	1.0	1.0	1.0	1.0	1.0			
A	8 MO (A) 15 S	0.5	1.5	2.0	11.0					
F	8 MO (U) 15 S	0.6	0.3	0.6	0.3	1.4	11.8			
0	9 MO (U) 15 S	0.7	0.5	0.7	0.5	1.9	10.7			
1	9 MO (U) 15 S	0.7	0.7	0.7	0.7	2.1	10.1			
7	D MO (B) 15 S	1.5	0.5	0.5	0.5	0.5	0.5	0.5	10.5	



4.4 Installing the Light Assembly

Rubber Tile - AV-70 and AV-70-HI only

The completed AV-70 rubber tile assembly is to be mounted on a surface capable of supporting 6kg minimum. Securing the rubber tile to the mounting surface is optional, however, Avlite recommend that the tile be secured at a minimum of two points.

- Insert bolts through the three-centremost holes in the tile, entering from the bottom face (within the triangular recess). It may be necessary to use a rubber mallet to insert the bolts.
 - Fit the AV-70 light over the bolts on the top face of the tile. (It is possible to align the lens ridge with the sides of the tile, but this is not a requirement).
 - Install a penny washer and a Nylock nut on each bolt and tighten.
 - Place the completed light assembly in the desired location.
 - During Installation every effort should be made to ensure that the light is level when installation is complete. When installing the tile ensure that it is level using a spirit level.
 - Using a hammer, drive steel pegs through the holes in the corners of the rubber tile being careful not to damage the AV-70 light.
- NOTE:** Other means of securing the tile may be used where the mounting surface is not suited to the use of steel pegs.

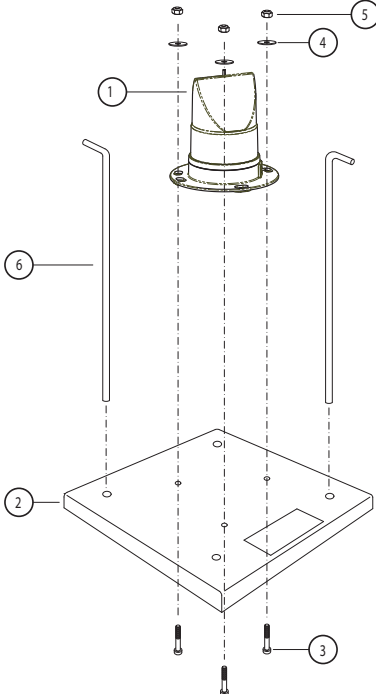

Item	Description	Qty
1	AV-70 Solar Airfield Light	1
2	Rubber Tile	1
3	Bolt, 8mm x 50	3
4	Penny Washer, 8mm	3
5	Nylock Nut, 8mm	3
6	Steel Peg, Ø12mm	Optional (2)

- NOTE:** RF lights should always be installed on mounting plates and stakes. Avlite does not recommend installation on rubber tiles.

Frangible Stake Mount

The completed AV-70 mount plate assembly is to be mounted on the Stake in firm soil (not loose sand, screenings or other unbound material).

- a. Fit the AV-70 light on the top of the mounting plate. Insert bolts through the four holes in the mount, entering from the bottom. Install a penny washer and a Nylock nut on each bolt and tighten.
- b. Fit the boss of the mount plate into the **shorter** barrel of the frangible sleeve. Using a 6mm Allen key, tighten the socket head cap screw against the stake mount boss.
- c. Use a sledge hammer to drive the stake into the soil at the chosen location. Drive the stake down until the bottom of the stake sleeve is at ground level.
During Installation every effort should be made to ensure that the light is level when installation is complete. When installing a stake mount into the ground ensure that the stake is installed straight into the ground and not on an angle. Ensure that the mounting plate is level using a spirit level.
- d. Fit the AV-70 mount plate assembly on top of the stake. The **longer** barrel of the Frangible Sleeve should completely cover the stake sleeve. Using a 6mm Allen key, tighten the bottom socket head cap screw against the stake sleeve.

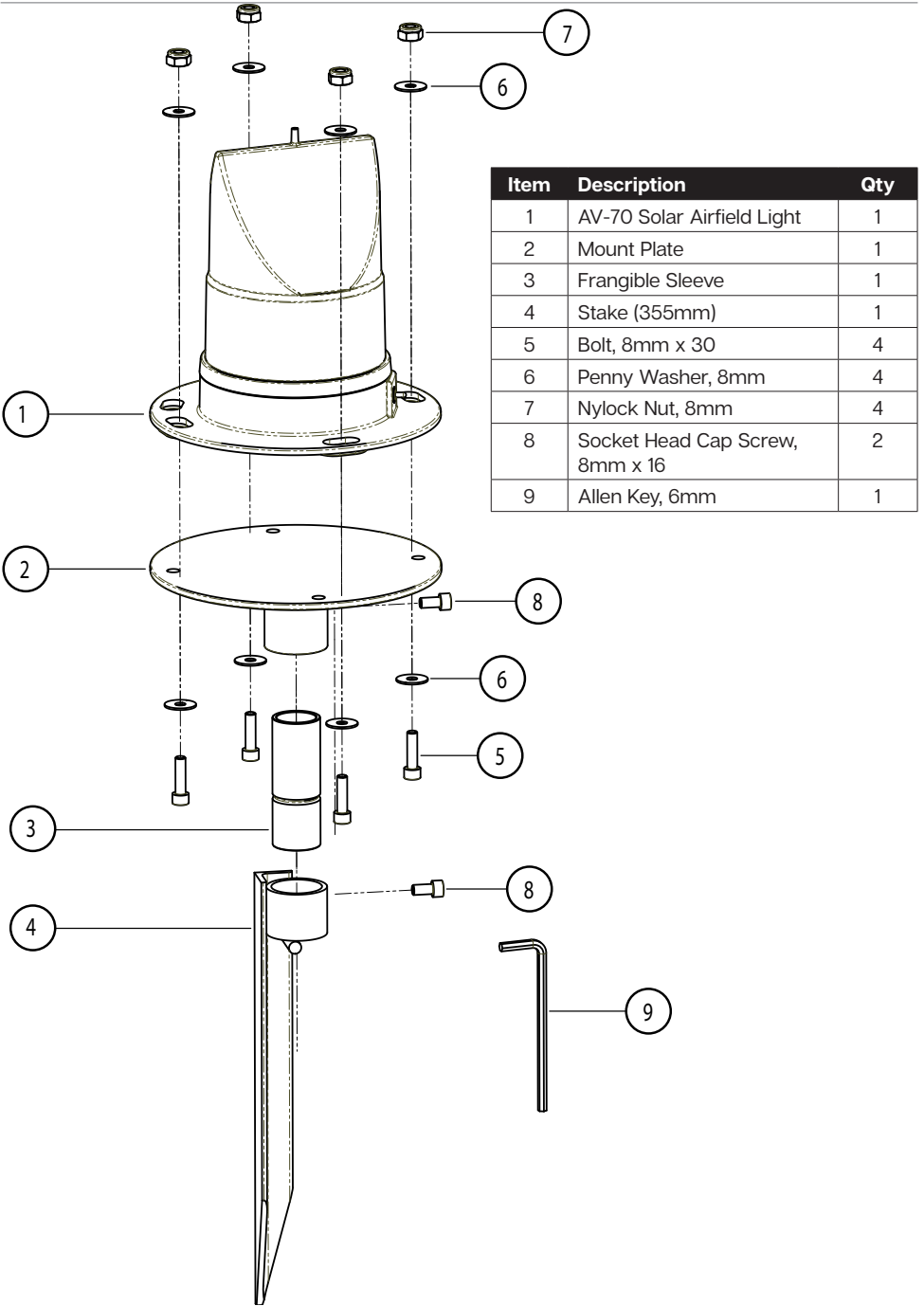

Item	Description	Qty
1	AV-70 Solar Airfield Light	1
2	Mount Plate	1
3	Frangible Sleeve	1
4	Stake (355mm)	1
5	Bolt, 8mm x 30	4
6	Penny Washer, 8mm	4
7	Nylock Nut, 8mm	4
8	Socket Head Cap Screw, 8mm x 16	2
9	Allen Key, 6mm	1

Frangible Concrete Mount

- a. Mount the base plate to the concrete using 4 x M8 concrete bolts.
- b. Fit the frangible mounting plate onto the concrete base plate and secure using the M8 x 16 SHCS
- c. During Installation every effort should be made to ensure that the light is level when installation is complete.

The following guidelines will help to ensure that the lights will be installed correctly.

- When installing a concrete mount plate ensure that the concrete pad is level using a spirit level.

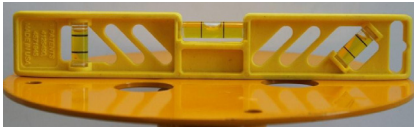

Check the mounting plate with a spirit level in all directions

- Fit the frangible coupling and top mounting plate and using a level check that the light mounting plate is level using a spirit level.
 - d. Fit the AV-70 to the light mounting plate using M8 SHCS, large flat washers and Nylock nuts.
- **NOTE:** After adjustments, ensure all nuts and bolts are tightened securely and all tools, spares and packaging are removed from the runway.
 - **NOTE:** Before activating the RF lights, the lights must be layed out on the runway in the location they will be installed.

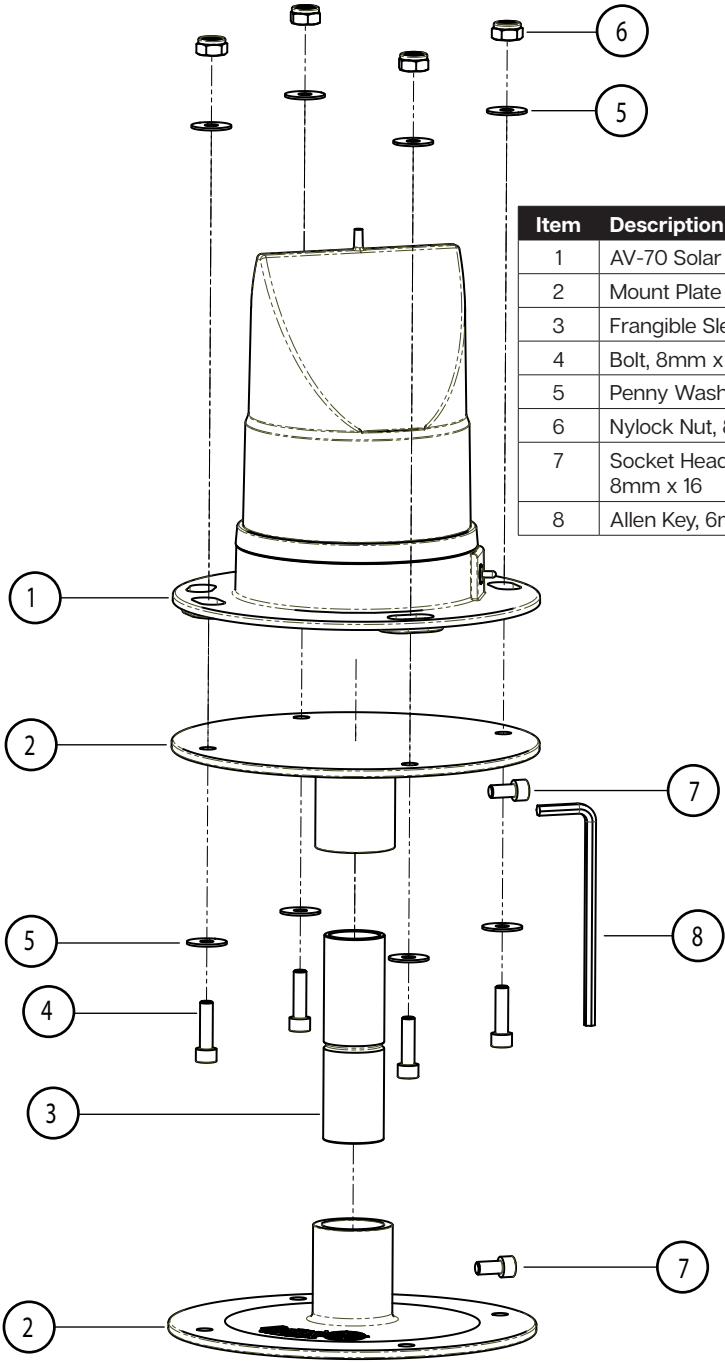

Item	Description	Qty
1	AV-70 Solar Airfield Light	1
2	Mount Plate	2
3	Frangible Sleeve	1
4	Bolt, 8mm x 25	4
5	Penny Washer, 8mm	4
6	Nylock Nut, 8mm	4
7	Socket Head Cap Screw, 8mm x 16	2
8	Allen Key, 6mm	1

4.5 Manual Light Activation via Momentary Button where fitted

The AV-70-RF lights are available with optional external momentary button for manual light operation.

The momentary button may be incorporated in the AV-70-RF for emergency use or in case the radio controller is lost or damaged. This button enables the user to manually turn the light on and step through the three different intensity levels.

To activate the AV-70-RF using the momentary button:-

- a. Hold down the push button for 3 seconds. (The light will activate in LOW intensity mode)
- b. Press the momentary button again it will adjust to MEDIUM intensity mode
- c. Press the momentary button a third time to achieve HIGH intensity mode
- d. Pressing the momentary button again will return the intensity to LOW.

When the light is activated from the momentary button, it will change its operation mode to "Dusk till Dawn". This will mean that the light will turn on when the ambient lighting conditions become dark, and will turn off when it detects daylight.

- **NOTE:** If the light is activated via the momentary button during daylight hours, it will stay on for 30 seconds before the photo sensor on the circuit board automatically turns the light off.
- **NOTE:** When the controller is found or repaired, the lights will revert back to radio control as soon as they receive a new message/command from the radio controller.
- **NOTE:** The lights will automatically reduce intensity to low after the TIMEOUT limit is reached. The timeout is set via the radio controller.



5.0 Avlite Radio Controller - RF Model

The Avlite Radio Controller is a compact handheld unit that allows complete control of the airfield lighting system. The unit allows for easy activation, inspection and testing of the airfield lights. The Avlite Radio Controller works on the 2.4GHz ISM Band using a low power RF module. The backlit, LCD can be seen during day or night. The straightforward menu provides ease of operation.

The Avlite Radio Controller comes standard with an IP68 rated charging plug, omni-directional antenna and ON/OFF switch and cover.

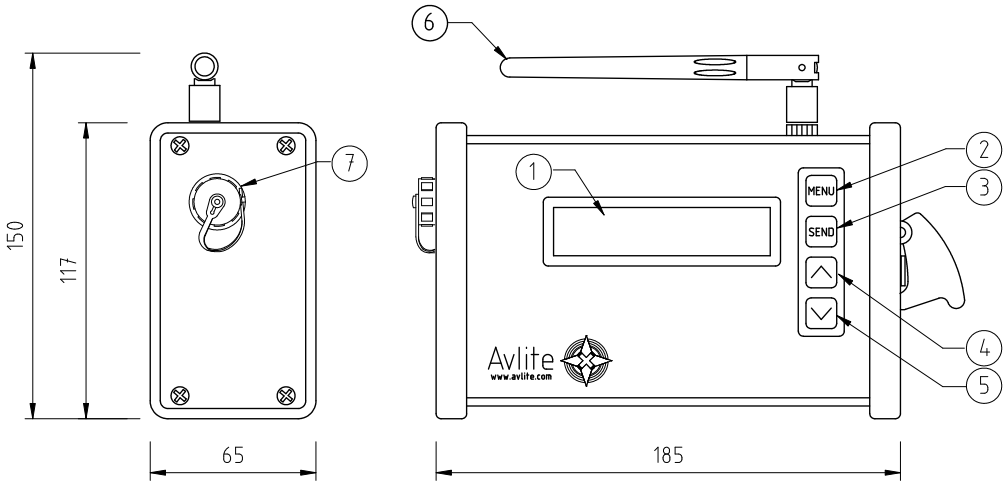

Fig 4 Radio Controller Side View

Fig 5 Radio Controller Front View

1. LCD Screen
2. MENU Button
3. SEND Button
4. UP Button
5. DOWN Button
6. 6" Di pole Omni Directional, Right Angle Whip Antenna
7. Charging Port – IP68 sealed plug. (Charger not shown)

5.1 Assembly and Installation of Radio Controller

The installation of the Radio Controller includes the following steps:-

- Unpacking
- Initial Inspection
- Assembling & Charging the Radio Controller
- Using the Radio Controller

Components

Your pelican case contains the following:

- 2.4GHz Radio Controller
- Charger
- Power Supply for charger
- Programming Cable

Please contact your Avlite office if there is any hardware missing.

Initial inspection

Inspect the Radio Controller for damage. If there is any damage, please contact your Avlite office. Retain original packing material for possible future use.

Assembly & Charging

The Radio Controller can be activated after raising the aerial into the upright position, see Fig 5.

It is advisable to charge the Radio Controller before use.

Turning the Unit On

To turn the unit on, lift the red missile cover and turn the switch to the ON position.

The radio controller will take 5 seconds to start up and it may take up to 30 seconds for the embedded RF Module to be configured, before a command can be sent.

Charging the Radio Controller

- a. Unscrew the protective cap from the charging port, on the left side of the Radio Controller.
- b. Insert the charging terminal into the Radio Controller.
- c. Plug the charger into a wall socket and turn the charger on.
- d. The light on the charger will flash Green, Orange, Red then back to Orange.
- e. The charger has a LED to indicate the charge sequence.
 - i. Green – Unit is fully charged. The Radio Controller can be left connected in state.
 - ii. Orange – Unit is charging. The unit will charge for a maximum of 8 hours before automatically shutting down.
 - iii. Red – A fault is occurring, please contact Avlite Office.



5.2 Radio Controller Menu

This section of the document will provide a short explanation of all the menu screens on the control unit.

Operation Mode

The Operation Mode defines how the light will respond to different environmental conditions & user inputs. There are three operational modes that can be selected via the controller; ALWAYS ON, STANDBY & DUSK to DAWN.

ALWAYS ON Operation Mode

The light is Always On. The light will be on both night & day until it is commanded to OFF. While the light is in this mode it will only turn off when the battery drops below the Flat Battery Voltage level. (AV-426 = 10.5V)

STANDBY Operation Mode

LEDs are OFF but light will respond to and pass commands sent by the radio controller. This mode should be used if the lights have been installed outside but are not currently required.

Note: The light is not completely powered down in a manner suitable for storage. If the light is to be stored in a warehouse or other dark environment the ON/OFF switch should be turned off.

DUSK to DAWN Operation Mode

The light is turned on and off based on the light sensor input. Sensors include a light sensor internal to each light and the light will turn on when the ambient light threshold falls below 100 lux and will turn off once the ambient light threshold reaches 150 lux.

Advanced Op Mode

This enables you to select visible or near IR LEDs. The options include VISIBLE LEDs & IR/ NVG LEDs.

- **NOTE:** this menu will not be enabled if the selected Operation Mode is STANDBY

Light Group

This menu is used to select the current light group. The controller can select any one of the 10 individual light groups. Taxiway lights, sign lights and runway lights are able to be controlled separately using programmable groups. (0 -> 9) or select all radio lights at once.

- **NOTE:** The units are set with a light group of 0 in the factory.

LED Intensity

Default = LOW

This menu is used to select the intensity of the LEDs on the light. The options include Low, Medium & High.

- Low – LED intensity is set to low setting
- Medium - LED intensity is set to medium intensity
- High - LED intensity is set to high intensity

- **NOTE:** this menu will not be enabled if the selected operational mode is STANDBY

Timeout Mode

The LED high intensity timeout feature allows the LEDs in the light to revert from high intensity to low intensity after a defined period of time (i.e. timeout duration). The three available timeout modes are described below:

Disabled

The high intensity LED timeout is disabled. The LED intensity will be selected via the LED intensity menu.

- **NOTE:** This menu is not available if the STANDBY operational mode has been selected.

Enabled, STANDBY

The LED will turn OFF and enter the STANDBY operational mode after the set Timeout duration.

Enabled, LOW

The LED intensity will revert from the initial LED intensity to the LOW setting after the set Timeout duration.

Timeout Duration

This menu is only visible when the timeout Mode is enabled. This menu is used to select the timeout duration, the time before the LED intensity reverts back to its LOW intensity state. The timeout duration can be set from 1 minute to 60 minutes.

Diagnostic

This feature can be used to check the status of every light in the airfield. The command can be sent any time and it will not affect the current state of the light. The light will respond to the battery diagnostic in either a Yes/No flash response. If the light is in STANDBY mode the light will flash as shown below and revert to STANDBY mode after the diagnostic has been completed. For additional diagnostic information please see Section 3 of the 'Radio Control System Setup' section of this manual.

BATTERY (FLAT): Battery below 10.5V.

BATTERY (LOW): Battery above 10.5V, but below 12.5V.

BATTERY (HEALTHY): Battery above 12.5V.

NODE (RESERVE): Checks which lights are nodes in the sub network.

NODE (PRIMARY): Checks which lights are nodes in the main network.

EXTERNAL POWER: Checks for external power connection.

Diagnostic Pass (1 x 1 second flash)

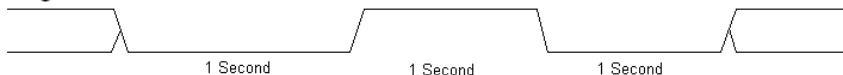

Diagnostic Fail (2 x 300 milli second flashes)



*For more information regarding the Yes/No flash response, please see section 5.1.7 of the AvMesh™ RF Communications Manual.



5.3 Using the Radio Control to Activate the Airfield Lighting System

The Radio Controller is very easy to use and by reading through the How To section below, all of the advanced features will be well within your grasp.

Make sure that all the lights in the same Light Group have had the rotary switches set correctly.

Turn All the Lights ON

- Turn the Radio Controller On
- Use the arrow keys to adjust the operational Mode to ON
- Press [MENU] button once to reach Light Group
- Set the Light Group to ALL
- Press [SEND] button
- Every radio light within range of the control unit will now turn on.

Setup the Lights to Operate in DUSK till DAWN mode

- Turn the Control unit On
- Use the arrow keys to adjust the operational Mode to DUSK till DAWN
- Press [MENU] button once to reach Light Group
- Set the Light Group to ALL
- Press [SEND] button
- Every radio light within range of the control unit will now turn on at night, during the day the lights will turn off automatically.

Runway B Only is to be HIGH Intensity, but Runway A will Remain in Current Configuration

- On Runway A, set the light group to 0 (follow the instruction in Section 2 in the 'Radio Control System Setup' section of this manual).
- On Runway B, set the light group to 1 or any group different to Runway A.
- Turn the Control unit On
- Use the arrow keys to adjust the operational Mode to Always On
- Press [MENU] button to reach Light Group
- Set the Light Group to 1
- Press [MENU] button to reach LED Intensity
- Use the arrow keys to adjust the LED Intensity to HIGH
- Press [MENU] button to reach Advanced Operation Mode
- Use the arrow keys to select Visible LEDs
- Press [SEND] button
 - Runway A will not change state.
 - Runway B will now be High Intensity.

Runway B Only is to be HIGH Intensity, with a Timeout of 8 Minutes and Runway A will be I/R Low Intensity

- On Runway A, set the light group to 0. (ie. set the rotary switches to A=0 B=0 inside the light head)
- On Runway B, set the light group to 1. (ie. set the rotary switches to A=1 B=1 inside the light head. Rotary switch A can be set to any value that is different from runway A.
- Turn the Control unit On
- Use the arrow keys to adjust the operational Mode to Always On
- Press [MENU] button to reach Light Group
- Set the Light Group to 1
- Press [MENU] button to reach LED Intensity
- Use the arrow keys to adjust the LED Intensity to HIGH
- Press [MENU] button to reach Timeout Mode
- Use the arrow keys to adjust the Timeout Mode to Enabled LOW
- Press [MENU] button to reach Timeout Duration
- Use the arrow keys to adjust the Timeout Duration to 8 Minutes
- Press [SEND] button
 - Runway A will not change state.
 - Runway B will now be High Intensity. After 8 minute Runway will revert back to LOW intensity.
- Press [MENU] button until you reach Light Group
- Set the Light Group to 0
- Press [MENU] button once to reach LED Intensity
- Use the arrow keys to adjust the LED Intensity to LOW
- Press [MENU] button to reach Advanced Operation Mode
- Use the arrow keys to select IR/NGV LEDs
- Press [SEND] button
 - Runway A will be in LOW Intensity IR mode
 - Runway B will not change state. Lights on Runway B will still receive and pass on the message intended for Runway A.



6.0 Maintenance and Servicing

Designed to be maintenance free, the AV-70 requires minimal attention, though the following maintenance and servicing information is provided to help ensure the life of your Avlite product.

General Maintenance

1. Cleaning Solar Panels - occasional cleaning of the solar panels may be required. Using a cloth and warm soapy water, wipe off any foreign matter before rinsing the panels with fresh water.
2. Battery Check - inspection of batteries should be performed every year for RF models and every three years (minimum) for AV-70 and AV-70-HI models to ensure that the charger, battery and ancillary electronics are functioning correctly. Using a voltage meter, check that the battery voltage is at least 3.6 volts under 100mA load, and ensure all terminals are clear of foreign matter.

Replacing the battery

The AV-70 lights are the only compact aviation light with a double sealed battery compartment. This provides the user with the ability to change the battery after years of operation.

1. Remove the light from either the Rubber tile or Frangible Mount.
2. Remove the marked flash adjustment bung from the base of the light and set internal toggle switch to 'OFF'.
3. Unscrew small screws to remove battery plate.
4. Remove battery from AV-70 case and unscrew positive and negative leads.
5. Discard old battery in a safe manner.
6. Reattach positive and negative leads to new battery and then place back into case.
7. Reattach battery plate and switch light 'ON' via internal switch. Replace the flash adjustment bung.
8. To test place dark cover (towel or jacket) on top of light to activate sensor, light will come on. For the AV-70-RF, the remote control will need to be used to test the operation of the light. (see '5.3 Using the Radio Control to activate the Airfield Lighting System' section of this manual for more information).

Care must be taken to observe the polarity of the battery before the leads are re-connected, and ensure the replacement battery is correctly fitted. Always discard old batteries in a safe manner.

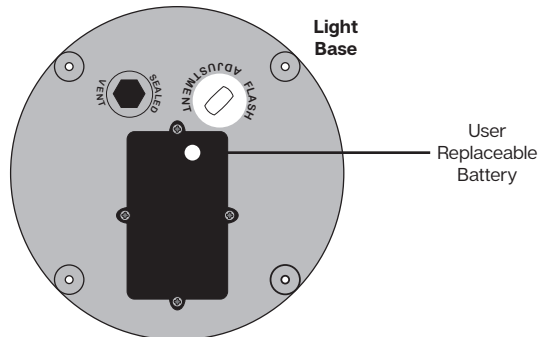

Long Term Storage Instructions

If the AV-70 is to be placed in storage for an extended period, being more than 5 months, please follow the below steps.

1. The 3.6V NiMH Battery must be stored in a fully charged condition.
2. Remove the Flash Adjustment plug and turn the ON/OFF switch to the OFF position.
3. Remove the battery cover and disconnect the Positive (+) Terminal.
4. Fold the Terminal away from the Negative Battery Terminal.
5. Replace the Battery Cover
6. Replace the Flash Adjustment Plug.

All batteries will discharge over time and the rate of discharge is dependent on temperature. If the light is being stored in temperatures greater than the optimum temperature (ie. 40°C for AV-70 and AV-70-HI and 30°C for AV-70-RF the battery will discharge faster.

Please check battery every 3-6 months for AV-70 and AV-70-HI and every 2 - 4 months for AV-70-RF. Recharge if necessary.

Recharging the Battery

1. Remove the Battery Cover and connect the Positive Terminal.
2. Remove the Flash Adjustment Plug and turn the ON/OFF switch to the ON position.
3. Reconnect the Light Head and place unit in the sun for 2-4 days

Or

Reconnect Light Head and place in front of a halogen lamp for 2-3 days. (Do not place the halogen light too close to the solar panel or the panel may be overheated)

Check the battery voltage regularly to make sure the unit is charging correctly.

After the battery has been recharged, switch the light OFF.



7.0 Trouble Shooting

Problem	Remedy
Light will not activate.	<ul style="list-style-type: none">• Ensure internal toggle switch is set to the 'ON' position.• Ensure light is in darkness.• Wait at least 60 seconds for the program to initialise in darkness if the light is set for DUSK till DAWN mode..• Ensure switch setting is on a valid code (See 'Flash Codes' section of this manual).• Ensure battery terminals are properly connected.• Ensure battery voltage is above 3.6volts.
Timing codes will not change.	<ul style="list-style-type: none">• Turn rotary switches several times to ensure contacts are clear.
Light will not operate for the entire night.	<ul style="list-style-type: none">• Expose light to direct sunlight and monitor operation for several days. Avlite products typically require 1.5 hours of direct sunlight per day to retain full autonomy. From a discharged state, the light may require several days of operational conditions to 'cycle' up to full autonomy.• Reducing the light output intensity or duty cycle (flash code) will reduce current draw on the battery.• Ensure solar module is clean and not covered by shading during the day.
Lights are constantly on during the day.	<ul style="list-style-type: none">• Ensure the flash code is not set to F F. This flash code is for testing purposes only and will be steady on for 24 hours a day.• Ensure the Radio Controller is not always set to ALWAYS ON (see "Operation Mode" in "5.2 Radio Controller Menu" for more information).
Light will not respond to controller in Radio Control Mode	Refer to AvMesh™ RF Communications System Installation and Trouble Shooting Manual, available under the AV-70 Downloads section.

All AV-70RF lanterns are fitted with a red status LED. This is found near the Flash Code Switches. It helps determine a fault with the unit depending on the flash rate of the status LED.

Flash Rate		Mode	Status	Condition
ON (sec.)	OFF			
Steady Off		Off	Normal	Normal running condition in daylight.
1/10	1	On	Normal	Lantern is not synchronised to other lanterns.
1	1	On	Normal	Lantern is synchronised to surrounding lanterns.
Steady On		Off	Flat Battery	Battery is flat.
1/10	1/10	On	Low Battery	Battery is low.
1	2/10	On	Factory Set.	Unit is in factory setup mode (FF). Change flash code.



Notes

Avlite Solution Verticals available



Airfield



Heliport



Obstruction



We believe technology improves navigation™

avlite.com info@avlite.com

Avlite Systems
Australia
+61 (0)3 5977 6128

Avlite USA LLC
USA
+1 (603) 737 1311

Avlite Asia Pte Ltd
Singapore
+65 6908 2917