

Avlite[®]
www.avlite.com



AV-426

Radio Controlled Solar Aviation Light
FAA - L861 and ICAO

INSTALLATION & SERVICE MANUAL

V5.0



Version No.	Description	Date	Reviewed	Approved	Design
5.0	AV-426 Manual Launch	June 2019	P. Naidu	W. Evans	M. Sugars

Table of Contents

1.0	Introduction	4
2.0	Technology	5
3.0	AV-426 Models L861, ICAO	6
3.1	AV-426 - Data Sheet	8
4.0	Activation	10
5.0	Installation	11
5.1	Simple Approach Lighting	14
5.2	Runway End Identifier Light (REIL)	15
6.0	Avlite Radio Controller	17
6.1	Assembly and Installation of Radio Controller	18
6.2	Radio Controller Menu	19
6.3	Radio Controller System Setup	21
6.4	Using the Radio Control to Activate the Airfield Lighting System (ALS)	30
7.0	Maintenance and Servicing	33
8.0	Troubleshooting	37
9.0	Documentation	39
10.0	AV-SB Solar Booster™	40
10.1	Solar Booster™ Installation Procedure	41



1.0 Introduction

Congratulations! By choosing to purchase an Avlite light, you have become the owner of one of the most advanced solar LED airfield lights in the world.

Avlite Systems draws on more than 25 years experience in the design and manufacture of navigation aids, and particular care has been taken to ensure your light gives years of trouble free service.

As a commitment to producing the highest quality products for our customers, Avlite has been independently certified as complying with the requirements of ISO 9001:2015 quality management system.

By taking a few moments to browse through this booklet, you will become familiar with the versatility of your light, and be able to maximise its operating function.

Please remember to complete the Avlite warranty registration at www.avlite.com.

2.0 Technology

Avlite Systems is a world-class solar lighting systems manufacturer with a proven reputation for rapid, innovative, and agile technology solutions designed specifically for defence, government, civil and humanitarian aid operations in the most remote, toughest environments.

Electronics

Avlite employs leading in-house electronic engineers in the design and development of software and related circuitry. All individual electronic components are sourced directly by Avlite procurement staff ensuring that only the highest quality components are used in our products.

LED Technology

All Avlite lights use the latest advancements in LED (Light Emitting Diode) technology as a light source. The major advantage of LED's over traditional light sources is well established in that they typically have an operational life in excess of 100,000 hours, resulting in substantial savings to maintenance and servicing costs.

Precision Construction

Commitment to investing in the design and construction of injection-moulded parts including optic lenses, light bases and a range of other components ensures that all Avlite products are of a consistent and superior quality.

Optical Performance

Avlite manufactures a range of aviation LED lenses moulded from multi-cavity dies. The company has superior in-house lens manufacturing capabilities to support outstanding optical performance.

Award-winning, Patented Technology

Several United States and Australian patent registrations are held on Avlite's range of innovative designs, with other regional patents pending in Canada, United Kingdom and Europe.



3.0 AV-426 Models

L-861, ICAO

The robust design of the AV-426 self-contained light ensures up to 12 years of reliable service with minimal ongoing maintenance.

Specifically designed to survive the harshest environments, the AV-426 features a grivory top and base and an aluminium internal chassis. The corners are made from UV stabilised rubber. This method allows the customer to change a solar panel in the unlikely event of damage.

The top casting is constructed with an integrated handle that helps with any manual handling of the unit.

The high impact resistant polycarbonate lens ensures even light visibility.

The solar panels provide efficient and year round charging of the large 12V 12Ah or 24Ah SLA battery (Tall model).

The four hole bolt pattern will fit directly onto any 200mm outside diameter (OD) mount.

The AV-426 is fitted with an external ON/OFF switch; this means the light can be turned on once in position, with the flick of a switch. It is also fitted with an external charging port for charging the battery while it is stored for extended periods.

When the AV-426 is used in conjunction with an RF Network (FCC compliant), a number of options are available such as the ability to use visible and IR LEDs fitted to the same light head. For more information about our AvMesh™ RF Communications Systems, please refer to the QuickStart Guide or the Installation and Trouble Shooting Manual available at www.avlite.com.

All this is backed by Avlite's industry leading, 3-year warranty.

To suit localised standards, the AV-426 can be supplied with optic head to comply with either FAA L-861 or ICAO Annex 14 photometrics.

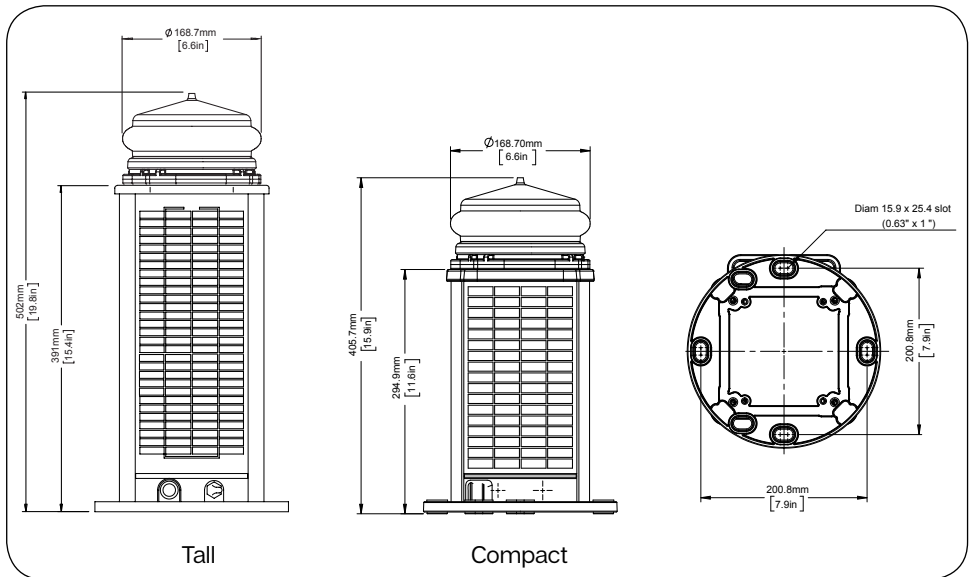



3.1 AV-426 - Data Sheet

	Standard	Compact
Light Characteristics		
Light Source	LED	
Available colours	Red, Green, White, Yellow, Blue, Bi-directional Combinations, IR	
Intensity Adjustments	FAA: Low (10%), Medium (30%), High (100%) ICAO: Low (20%), Medium (40%), High (100%)	
Operating time at maximum intensity*	112 hours	56 hours
LED Life Expectancy (hours)	>100,000	
Electrical Characteristics		
Circuit Protection	Integrated	
Operating Voltage (VDC)	12	
Temperature Range	-40 to 80°C	
Solar Characteristics		
Solar Module Type	Monocrystalline	
Output (watts)	28 (4 x 7watt)	20 (4 x 5watt)
Charging Regulation	MPPT	
Power Supply		
Battery Type	SLA (Sealed Lead Acid)	
Battery Capacity (Ah)	24	12
Nominal Voltage (VDC)	12	
Radio Controlled		
Frequency	2.4GHz ISM Band	
Range	Up to 1.4km relayed	
Expandability	AvMesh®	
Compliance	FCC / CE	
Physical Characteristics		
Body Material	Composite Polymer	
Lens Material	LEXAN® Polycarbonate – UV stabilized	
Lens Diameter (mm/inches)	168 / 6⅝	
Lens Design	Multi-LED optic	
Mounting	4 hole 200mm bolt pattern	
Height (mm/inches)	503 / 20	406 / 16
Width (mm/inches)	234 / 9¼	234 / 9¼
Mass (kg/lbs)	14 / 30¼	9.1 / 20
Product Life Expectancy	Up to 12 years	

Environmental Factors	
Humidity	0 to 100%, MIL-STD-810F
Icing	3.41kg per square cm / 48.5lbs per square inch
Wind Speed	Up to 160kph / 100mph
Shock	MIL-STD-202G, Test Condition G, Method 213B
Vibration	MIL-STD202G, Test Condition B, Method 204
Certifications	
CE	EN61000-6-3:1997. EN61000-6-1:1997
Quality Assurance	ISO9001:2015
Waterproof	IP68
Photometrics: • Runway Edge, Threshold & End configurations	FAA AC150/5345-46-L861, L861E ICAO Annex 14, Vol I, July 2016
Uni Approach (steady)	650cd
• REIL, Runway End Identification Light	700cd
Intellectual Property	
Patents	Patents pending
Trademarks	AVLITE® is a registered trademark of Avlite Systems
Warranty *	3 year warranty
Options Available	<ul style="list-style-type: none"> • Avlite Pilot Activated Lighting Control <ul style="list-style-type: none"> • IR LEDs • Solar Booster™ • Without RF Radio Control

*For the latest Warranty Information, visit www.avlite.com/warranty-statement/



4.0 Activation

Charging the Battery

New lights should be left in the sun for several days to ensure battery is charged before placing in service.

Preferred Installation Location

For best light performance, ensure solar modules are not covered and are in clear view of the sky with no shadows.

Lantern Operation

The AV-426 is activated via the ON/OFF switch, at the base of the unit.

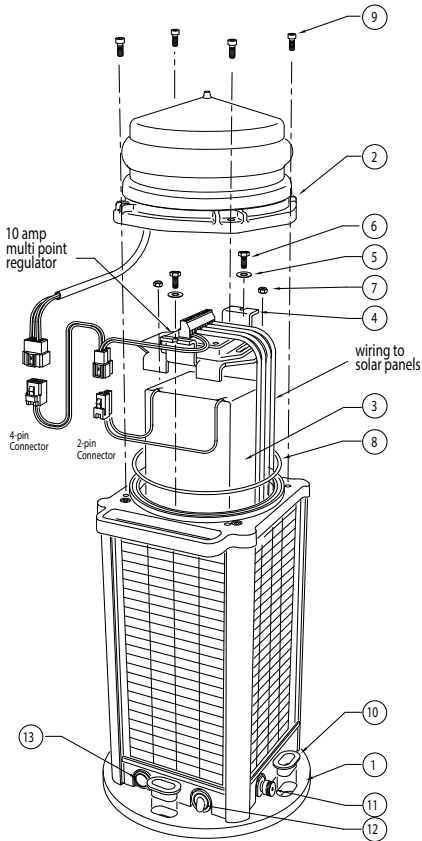

Item	Description	Quantity
1	AV426 Base	1
2	AV426 Lens Assembly	1
3	Battery 12v 24Ah	1
4	Battery Clamp	1
5	Washer M4	2
6	M4 Cap Screw	2
7	M5 Nylock Nut	2
8	O-Ring, ID 145 x 4.0	1
9	Socket Head Screw M6 x 16	4
10	Mounting Insert	4
11	External Charging Port	1
12	ON/OFF Switch	1
13	Momentary Button	1

5.0 Installation

FAA Guidelines shown

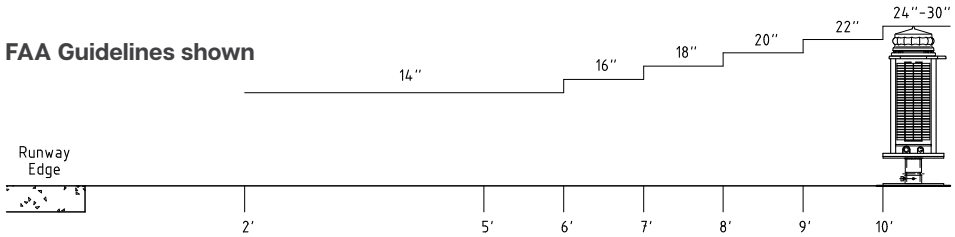

Between 2ft and 5ft from Runway Edge maximum light fixture height is 14 inches.

(Note: A 6 inch clearance must be maintained between the light fixture and any overhanging part of an aircraft).

Between 6ft and 10ft from Runway Edge the light fixture height may increase 2 inches per foot. At 10ft from Runway Edge maximum light fixture height is 30 inches.

Installing the Light Assembly to the Frangible Stake Mount

The completed AV-426 mount plate assembly is to be mounted on the stake in firm soil (not loose sand, screenings or other unbound material).

- Fit the AV-426 on the top of the mounting plate. Insert bolts through the four holes in the mount, entering from the bottom. Install a penny washer and a Nylock nut on each bolt. Tighten Nylock nuts.
 - Use a sledge hammer to drive the stake into the soil at the chosen location. Drive the stake down until the bottom of the stake sleeve is at ground level.
 - Fit the AV-426 and mounting plate assembly on top of the stake. The point of frangibility should be completely clear of the stake sleeve or ground support hardware. Use the socket head cap screws supplied to hold the frangibility point above the sleeve. Using a 6mm Allen key, tighten the bottom socket head cap screws against the stake sleeve.
- NOTE:** After adjustments, ensure all nuts and bolts are tightened securely and all tools, spares and packaging are removed from the runway.

Installing the Light Assembly to the Frangible Concrete Mount

- Mount the base plate to the concrete using 4 x M8 concrete bolts.
 - Fit the frangible mounting plate onto the concrete base plate and secure using the M8 x 16 SHCS
 - Level the light mounting plate using a spirit level.
 - Fit the AV-426 to the light mounting plate using M8 SHCS, large flat washers and Nylock nuts.
 - For further adjustments on levelling the light, see next section on levelling the light.
- NOTE:** After adjustments, ensure all nuts and bolts are tightened securely and all tools, spares and packaging are removed from the runway.

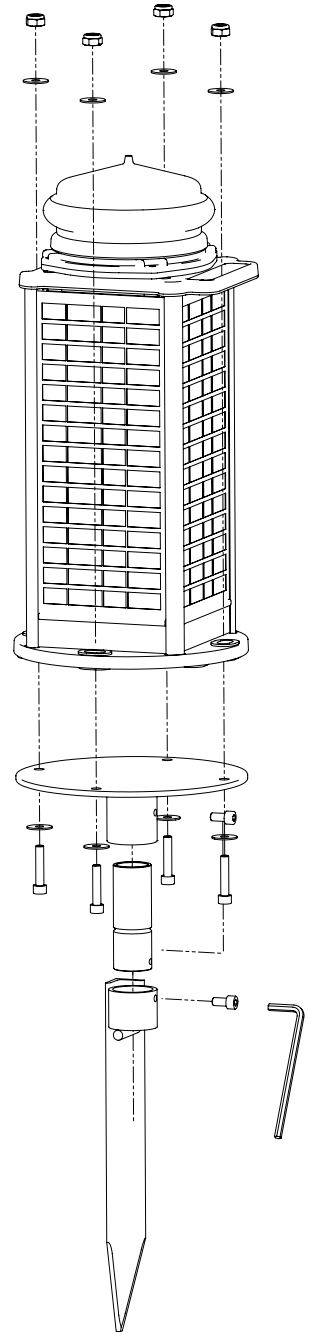
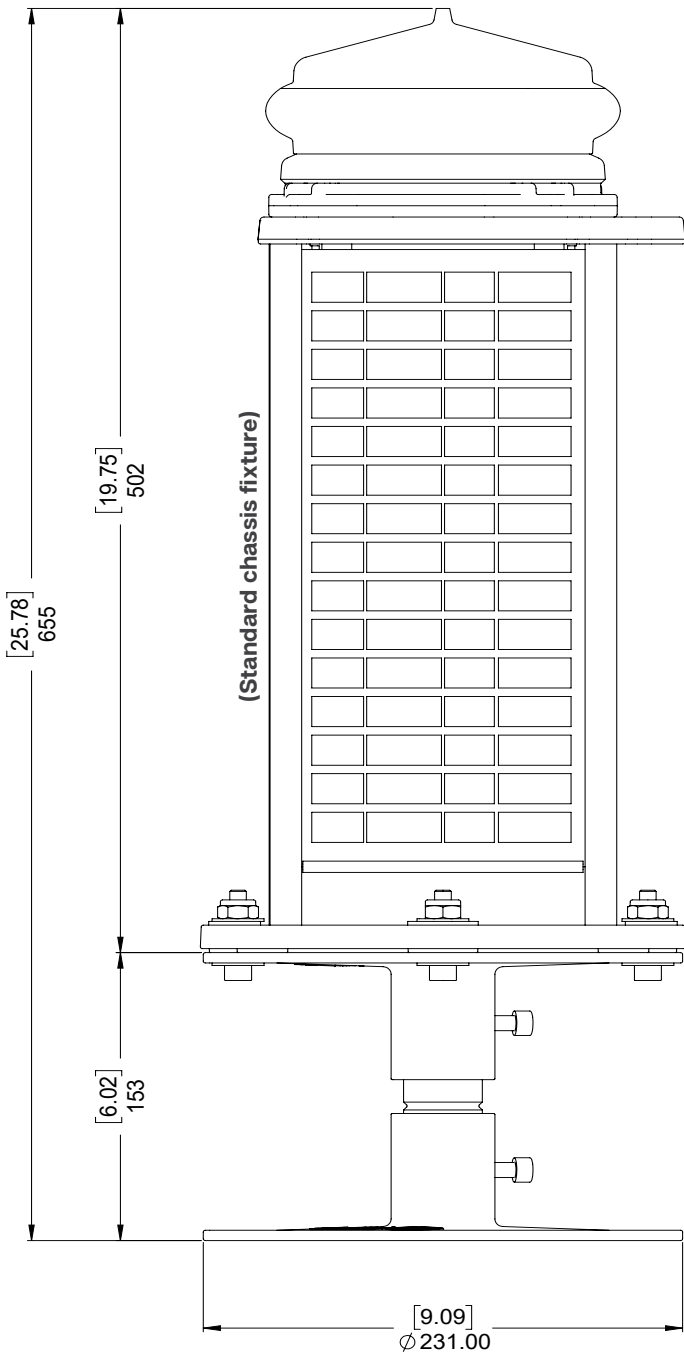

Levelling the light

During Installation every effort should be made to ensure that the light is level when installation is complete.

The following guide lines will help to ensure that the lights will be installed correctly:

- When installing a stake mount into the ground ensure that the stake is installed straight into the ground and not on an angle.
- When installing a concrete mount plate ensure that the concrete pad is level using a spirit level.



Check the mounting plate with a spirit level in all directions

- Fit the frangible coupling and top mounting plate and using a spirit level check that the light mounting plate is level using a spirit level.
- If the mounting assembly can not be levelled to a satisfactory plane, then spacers can be used under the 4 mounting points to complete levelling.
- Spacers must be secured. Flat penny Washers can be placed under the 4 mounting points and secured in place by the mounting bolts.



- Washers of different thicknesses can be used, as can multiple washers.



Correct Installation

Important: Please ensure that spacers are not just under one mounting point. Please fill in spacers under other mounting points. Failure to space gaps will result in damage to the base or the mounting plate.



5.1 Simple Approach Lighting

The AV-426 can be configured into a simple approach lighting system. A simple approach lighting system is a lighting system intended for a non-instrument or a non-precision approach runway. This is done through selecting different sync delay or sync offset.

All lights must be in the same light group and the same REIL group. Sync option must be activated in the system menu. Flash code selected must be the same. Each individual light is then set with a sync delay or sync offset.

Please refer to **Section 6.3 Radio Controller System Setup**, Section 2, 'Programming the light using the cable interface and handheld controller', paragraph G or H on Sync offset and Sync Delay for information on how to set Sync Offset or Sync delay.



NOTICE:

The information contained in this publication is advisory only. Please contact your local authority for rules and regulations particular to your region.

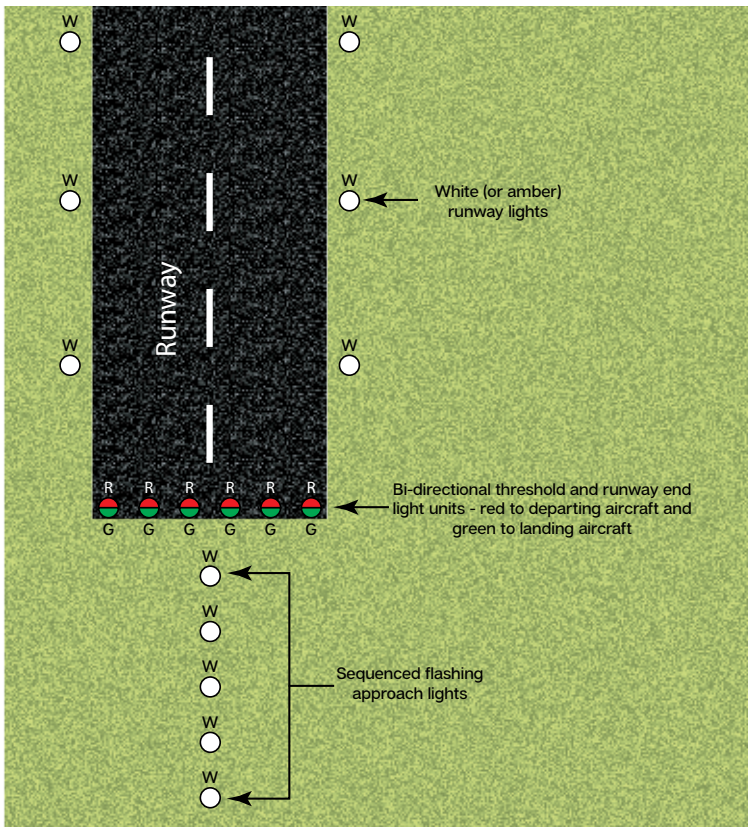

5.2 Runway End Identifier Light (REIL)

The AV-426 is available in a REIL configuration and must be ordered preset from the factory. It is not possible to configure a REIL from a standard AV-426 runway edge light.

REILs will be pre-programmed and clearly labelled upon dispatch. REILs from the same light group and same REIL group must be installed together.

The recommended flash character for a REIL is 112 (120 FPM).

REIL Groups

A REIL group is the group of lights that will flash in sync together. REILs from different REIL groups will not flash in sync together.

When installing 2 pairs of REILs on the airfield one pair at each end, it is advisable to ensure they are in different light groups and different REIL groups.

Please refer to **Section 6.3 Radio Controller System Setup**, Section 2, 'Programming the light using the cable interface and handheld controller', paragraph D on light groups for information on how to set a light group.



NOTICE:

The information contained in this publication is advisory only.
Please contact your local authority for rules and regulations particular to your region.

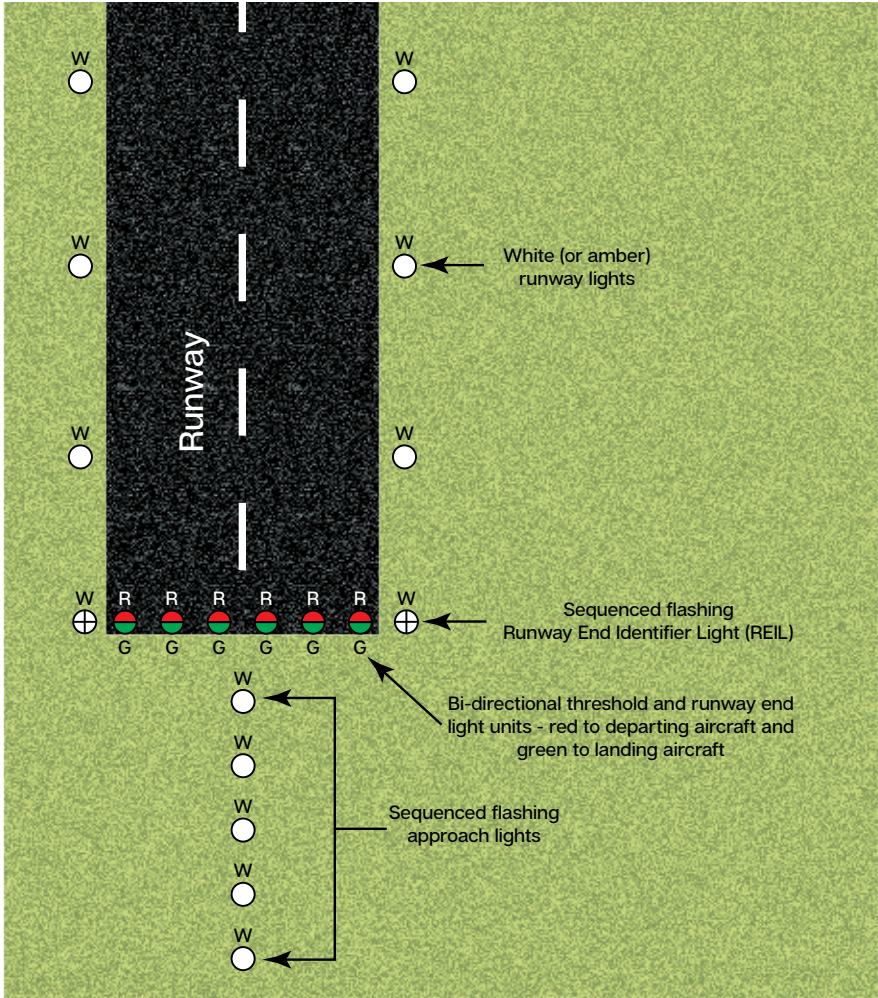

6.0 Avlite Radio Controller

The Avlite Radio Controller is a compact handheld unit that allows complete control of the airfield lighting system. The unit allows for easy activation, inspection and testing of the airfield lights. The Avlite Radio Controller works on the 2.4GHz ISM Band using a low power RF module. The backlit, LCD can be seen during day or night. The straightforward menu provides ease of operation.

The Avlite Radio Controller comes standard with an IP68 rated charging plug, omni-directional antenna and ON/OFF switch and cover.

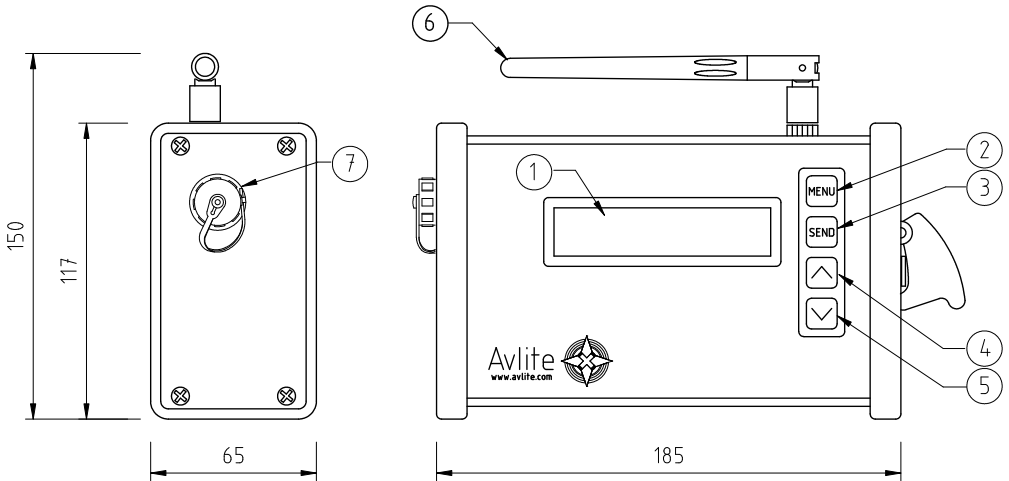

Fig 4 Radio Controller Side View

Fig 5 Radio Controller Front View

1. LCD Screen
2. MENU Button
3. SEND Button
4. UP Button
5. DOWN Button
6. 6" Di pole Omni Directional, Right Angle Whip Antenna
7. Charging Port – IP68 sealed plug. (Charger not shown)



6.1 Assembly and Installation of Radio Controller

The installation of the Radio Controller includes the following steps:-

- Unpacking
- Initial Inspection
- Assembling & Charging the Radio Controller
- Using the Radio Controller

Components

Your pelican case contains the following:

- 2.4GHz Radio Controller
- Charger
- Power Supply for charger
- Programming Cable

Please contact your Avlite office if there is any hardware missing.

Initial inspection

Inspect the Radio Controller for damage. If there is any damage, please contact your Avlite office. Retain original packing material for possible future use.

Assembly & Charging

The Radio Controller can be activated after raising the aerial into the upright position.

It is advisable to charge the Radio Controller before use.

Turning the Unit On

To turn the unit on, lift the red missile cover and turn the switch to the ON position.

The radio controller will take 5 seconds to start up and it may take up to 30 seconds for the embedded RF Module to be configured, before a command can be sent.

Charging the Radio Controller

- a. Unscrew the protective cap from the charging port, on the left side of the Radio Controller.
- b. Insert the charging terminal into the Radio Controller.
- c. Plug the charger into a wall socket and turn the charger on.
- d. The light on the charger will flash Green, Orange, Red then back to Orange.
- e. The charger has a LED to indicate the charge sequence.
 - i. Green – Unit is fully charged. The Radio Controller can be left connected in state.
 - ii. Orange – Unit is charging. The unit will charge for a maximum of 8 hours before automatically shutting down.
 - iii. Red – A fault is occurring, please contact Avlite Office.

6.2 Radio Controller Menu

This section of the document will provide a short explanation of all the menu screens on the control unit.

Operation Mode

The Operation Mode defines how the light will respond to different environmental conditions & user inputs. There are three operational modes that can be selected via the controller; ON, STANDBY & DUSK to DAWN.

ALWAYS ON Operation Mode

The light is Always On. The light will be on both night & day until it is commanded to OFF. While the light is in this mode it will only turn off when the battery drops below the Flat Battery Voltage level. (AV-426 = 10.5V)

STANDBY Operation Mode

LEDs are OFF but light will respond to and pass commands sent by the radio controller. This mode should be used if the lights have been installed outside but are not currently required.

Note: The light is not completely powered down in a manner suitable for storage. If the light is to be stored in a warehouse or other dark environment the ON/OFF switch should be turned off.

DUSK to DAWN Operation Mode

The light is turned on and off based on the light sensor input. Sensors include a light sensor internal to each light and the light will turn on when the ambient light threshold falls below 100 lux and will turn off once the ambient light threshold reaches 150 lux.

Advanced Op Mode

This enables you to select visible or near IR LEDs. The options include VISIBLE LEDs & IR/ NVG LEDs.

- **NOTE:** this menu will not be enabled if the selected Operation Mode is STANDBY

Light Group

This menu is used to select the current light group. The controller can select any one of the 10 individual light groups. Taxiway lights, sign lights and runway lights are able to be controlled separately using programmable groups.

(0 -> 9) or select all radio lights at once.

- **NOTE:** The units are set with a light group of 0 in the factory.

LED Intensity

Default = LOW

This menu is used to select the intensity of the LEDs on the light. The options include Low, Medium & High.

- Low – LED intensity is set to low setting
- Medium - LED intensity is set to medium intensity
- High - LED intensity is set to high intensity

- **NOTE:** this menu will not be enabled if the selected operational mode is STANDBY



Timeout Mode

The LED high intensity timeout feature allows the LEDs in the light to revert from high intensity to low intensity after a defined period of time (i.e. timeout duration). The three available timeout modes are described below:

Disabled

The high intensity LED timeout is disabled. The LED intensity will be selected via the LED intensity menu.

- **NOTE:** This menu is not available if the STANDBY operational mode has been selected.

Enabled, STANDBY

The LED will turn OFF and enter the STANDBY operational mode after the set Timeout duration.

Enabled, LOW

The LED intensity will revert from the initial LED intensity to the LOW setting after the set Timeout duration.

Timeout Duration

This menu is only visible when the timeout Mode is enabled. This menu is used to select the timeout duration, the time before the LED intensity reverts back to its LOW intensity state. The timeout duration can be set from 1 minute to 60 minutes.

Diagnostic

This feature can be used to check the status of every light in the airfield. The command can be sent any time and it will not affect the current state of the light. The light will respond to the battery diagnostic in either a Yes/No flash response. If the light is in STANDBY mode the light will flash as shown below and revert to STANDBY mode after the diagnostic has been completed. For additional diagnostic information please see Section 3 of the 'Radio Control System Setup' section of this manual.

BATTERY (FLAT): Battery below 10.5V.

BATTERY (LOW): Battery above 10.5V, but below 12.5V.

BATTERY (HEALTHY): Battery above 12.5V.

NODE (RESERVE): Checks which lights are nodes in the sub network.

NODE (PRIMARY): Checks which lights are nodes in the main network.

EXTERNAL POWER: Checks for external power connection.

Diagnostic Pass (1 x 1 second flash)

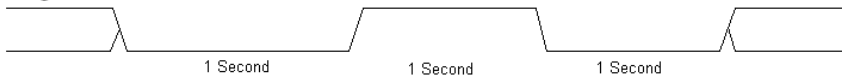

Diagnostic Fail (2 x 300 milli second flashes)



*For more information regarding the Yes/No flash response, please see section 5.1.7 of the AvMesh™ RF Communications Manual.

Radio Encryption

The AV-426 is fitted with 128bit Radio Encryption. This includes user-adjustable encryption keys and 12 user-adjustable channel settings.

Synchronization

The integrated mesh network radio system can provide true synchronization flash patterns including flare paths and approach sequences.

Sending Commands

Every time the SEND button is pressed a command is sent containing all the current settings in the Radio Controller.

The SEND button can be used after changing one setting or after changing multiple settings.

6.3 Radio Controller System Setup

Your radio control system has been shipped preprogrammed with a default 128 bit encryption key. It is not necessary to alter the default encryption key, however, if required the encryption key can be changed (see Section 1.5. i).

- **NOTE: If you change the radio control encryption key in Section 1, it will be necessary to change the encryption key in ALL the lights in the system**

To ensure trouble free set up of the Radio control System it is necessary to step through the following set up procedures. The setting up of the Radio control system is divided into 3 sections

Section 1 - Programming the Radio Control System (must be done before Section 2 & 3).

Section 2 - Programming the light, using the cable and handheld controller.

Section 3 - Operating the lights using the ALS 2.4GHz Handheld Controller.



Section 1

Programming the Radio Control System

1. Fold out the aerial on the top of the ALS 2.4 GHz Handheld Radio Controller.
2. Turn on the ALS 2.4GHz Handheld Radio Controller by actuating the red rocket switch on the side of the controller



3. Press and hold the menu button for 3 seconds
4. The screen will display the following message:
5. The Menu contains the following Sub menu
(Press the Menu button to step between the menu items)
 - a. [Screen back light]**
Using the [UP] or [DOWN] keys select from:
[0-100%]
 - b. [Connection Method]**
Using the [UP] or [DOWN] keys select from:
[Radio Control] - standard wireless connection
[Direct Connection] - use for programming light
 - c. [Flash Code Selection]**
Using the [UP] or [DOWN] keys select from:
[Disable]
[Enable]
 - d. [Sync Menu Selection]**
Using the [UP] or [DOWN] keys select from:
[Disabled]
[Enabled]

e. [Advanced Operation]

Using the [UP] or [DOWN] keys select from:
[Disabled]
[Enabled]

f. [Diagnostic]

Using the [UP] or [DOWN] keys select from:
[Disabled]
[Enabled]

g. [Radio Information]

Displays the address of the radio in the ALS2.4GHz Hand Held Controller
Note: There are no user-adjustable settings in this menu item

h. [Radio Channel]

Note: There are two sub menus in this menu. To toggle between the two Sub menus, press both the [UP] and [DOWN] keys together at the same time.

Using the [UP] or [DOWN] keys select from:
[Encrypted]
[Unencrypted]

Using the [UP] or [DOWN] keys select from:
[0C-17]

i. [Radio Encryption Key]

NOTE: If you change the radio control encryption key in Section 1, it will be necessary to change the encryption key in ALL the lights in the system

Using the [UP] and [DOWN] keys set the encryption key. Hold down the key to scroll quickly to the required number.

Pressing both the [UP] and [DOWN] keys together will toggle across the encryption key in banks of 2 digits.

Set the encryption key in banks of 2 digits.

For Example:

To set an encryption Key of 12345678910111213141

The digits would be set in pairs of 12 34 56 78 91 01 11 21 31 41

Using the [UP] or [DOWN] keys select any combination from
[00000000000000000000 to FFFFFFFFFFFFFFFFFFFFFF]

Record and keep this Encryption key secure in case the controller becomes lost or broken.



The encryption key can be re-entered into the new controller without the need to reprogram all the lights in the Radio Control System.

Encryption key cannot be 00000000000000000000

Press [SEND] to save the Radio Control System settings

- **NOTE:** Failure to select appropriate settings and save the settings will result in the Radio Control System not being appropriately optioned.

Congratulations you have now set up your Radio Control System. Please continue to the next section to setup each light in the system.

Section 2

Programming the light using the cable interface and handheld controller

- **NOTE:** In this programming mode it is necessary to press send to save each option as each option is selected in the sub menu, before moving to the next sub menu item. Failure to press send before moving to the next menu item will result in selections not being saved.
1. The programming port is located under the light head. It is necessary to remove the light head to access this programming port.
 2. Ensure that the light is turned off at the master switch on the control panel at the base of the solar unit
 3. Remove the 4 socket head cap screws and remove the light head from the solar unit enough to access the programming port. The light needs to remain connected the solar unit. Remove the blue waterproof cap from the programming port.



Programming Port
Replace blue cap after programming

4. Connect the programming cable to the light head.
5. Connect the programming cable to the programming/charging port located on the left hand side of the ALS2.4GHz handheld radio controller.
6. Turn on the controller at the Red Master switch located on the right hand side of the ALS 2.4 GHz handheld radio controller.

7. Turn on the light at the master switch on the solar chassis.
8. Unit is ready to receive programming signals.
 - **NOTE:** Light head needs to be connected to the solar chassis during programming to be able to receive power enabling it to be programmed.
9. Press and hold the [MENU] button for 3 Seconds. The screen will display the following message.



10. Using the menu key scroll down the sub menu to [CONNECTION METHOD]
11. Using the [UP] and [Down] keys select [DIRECT CONNECTION]



12. Press [SEND]
13. This Menu contains the following Sub Menu
Press [MENU] to scroll through the menu
 - **NOTE:** In this menu the programmed option will be indicated by a ✓, if the option is indicated by an X then this option has not been selected and saved. Press [SEND] to save options at each change.

a. Lantern Info

This displays the current Light information only, there are no adjustable options.

Type
Version
Radio



b. Operation Mode

Using the [UP and [DOWN] keys select from the following:

- [Always On]
- [Dusk till Dawn]
- [Standby]

Press [SEND] after selection

c. Advanced Operation Mode (if Advanced Operation Mode is enabled during Radio Control System Programming - Section 1)

Using the [UP and [DOWN] keys select from the following:

- [Visible LEDES]
- [IR/NVG LEDES]

Press [SEND] after selection

d. Light Group

Using the [UP and [DOWN] keys select from the following:

- [0-15] (Select any one of the 0-15 light groups)

Press [SEND] after selection

e. Intensity

Using the [UP and [DOWN] keys select from the following

- [Low]
- [Medium]
- [High]

Press [SEND] after selection

f. Flash Code (if Flash Code is enabled during Radio Control System Programming - Section 1)

Using the [UP and [DOWN] keys select from the following

- [000 to 1FF]

A full list of available flash codes is available from Avlite

Press [SEND] after selection

g. Sync Offset (if Synchronisation is enabled during Radio Control System Programming - Section 1)

- **NOTE:** Sync offsets can be set using an absolute value or a percentage (Flash Delay) of the flash sequence or a combination or both. If you select Sync Offset value and also Sync delay value, the combination offset/delay value will be the combined total off both values.

Using the [UP and [DOWN] keys select from the following:

- [-10.23 to +10.23] seconds

Press [SEND] after selection

h. Sync Delay (if Synchronisation is enabled during Radio Control System Programming - Section 1)

Using the [UP] and [DOWN] keys select from the following

[0 to 99.6%]

Press [SEND] after selection

i. Radio Channel

- **NOTE:** There are two sub menus in this menu. To toggle between the two Sub menus, press both the [UP] and [DOWN] keys together at the same time.

Using the [UP] or [DOWN] keys select from:

[Encrypted]

[Unencrypted]

Using the [UP] or [DOWN] keys select from:

[0C-17]

Press [SEND] after selection

j. Radio Encryption Key (If Encryption is Enabled during Radio Control System Programming- Section 1)

Set the encryption key in banks of 2 digits.

For Example

To set an encryption Key of 12345678910111213141

The digits would be set in pairs of 12 34 56 78 91 01 11 21 31 41

Using the [UP] and [DOWN] keys set the encryption key. Hold down the key to scroll quickly to the required number.

Pressing both the [UP] and [DOWN] keys together will toggle across the encryption key in banks of 2 digits.

[Insert Radio Encryption Key]

- **NOTE:** Radio Encryption Key must be the same key as set in the Radio Control system (section 1)] or the light will not respond to the controller.

Press [SEND] after selection

- **NOTE:** Turn the light off at the master switch, before disconnecting the Hand Held Radio interface cable. The light must be depowered before the settings will take effect.

Repeat this process for every light in the system



Important: When you have finished programming all of the lights the Radio Controller must be put back into Radio Connection Mode

1. Using the menu key scroll down the sub menu to [CONNECTION METHOD]
2. Using the [UP] and [DOWN] keys select [RADIO CONNECTION]
3. Press [SEND] to save settings.

Failure to place the Radio Controller back into RADIO CONNECTION mode will cause the Radio Controller to be unable to communicate with the lights

Congratulations you have now programmed your lights to your Radio Control System please continue to the next section.

Section 3

Operating the lights using the ALS 2.4GHz Handheld Controller

NOTE: Some menu options may not appear if they were not enabled in the Radio Control System set up menu, and programmed in to the light.

1. Fold out the aerial on the top of the ALS 2.4 GHz handheld Controller.
2. Turn on the ALS 2.4GHz Handheld radio Controller by actuating the red rocket switch on the side of the controller
3. The Menu contains the following Sub menu

Press the [MENU] button to scroll through the Sub Menu

a. Operation Mode

Using the [UP and [DOWN] keys select from the following:

- [Always On]
- [Dusk till Dawn]
- [Standby]

b. Advanced Operation Mode (If Enabled during Radio Control System Programming- Section 1)

Using the [UP and [DOWN] keys select from the following:

- [Visible LEDs]
- [IR/NVG LEDs]

c. Light group

Using the [UP and [DOWN] keys select from the following:

- [0-9] (Select any one of the 10 light groups)
- [All] (Selects all of the light groups)

d. Intensity

Using the [UP and [DOWN] keys select from the following:

- [Low]
- [Medium]
- [High]

e. Timeout Mode

Using the [UP and [DOWN] keys select from the following:

- [Enabled, Low] (Recommended)
- [Disabled]

f. Timeout Duration

Using the [UP and [DOWN] keys select from the following:

- [1-60 Minutes]

g. Flash Code (If Enabled during Radio Control System Programming- Section 1)

Using the [UP and [DOWN] keys select from the following

- [000 to 1FF]

h. Sync Mode (If Enabled during Radio Control System Programming- Section 1)

Using the [UP and [DOWN] keys select from the following:

- [Full] (Use for Flare Path or Approach sequence)
- [Basic] (Use for synchronised Flashing)
- [Disabled]

i. Diagnostic

For the following diagnostic tests, the following diagnostic flash results can be displayed for the light.

Diagnostic Pass (1 x 1 second flash)

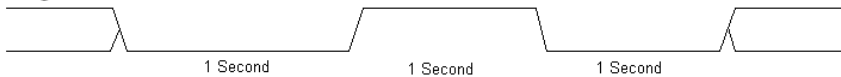

Diagnostic Fail (2 x 300 milli second flashes)





Using the [UP and [DOWN] keys select from the following

Battery (Flat)

Pass = Confirms light voltage is under 10.5V

Battery (Low)

Pass = Confirms light voltage is between 10.5 and 12.5V

Battery (Healthy)

Pass = Confirms battery voltage is over 12.5 Volts

Node (Reserve)

Pass = Confirms light is a node on the Sub Network

Node (Primary)

Pass = Confirms light is a node on the Main Network

External Power

Pass = Confirms external power is connected via HVPS

Press [SEND] to receive a diagnostic flash sequence

When the controller is in operation mode, multiple changes can be set and sent at the same time. It is not necessary to press send after each change.

6.4 Using the Radio Control to Activate the Airfield Lighting System

The Radio Controller is very easy to use and by reading through the How To section below, all of the advanced features will be well within your grasp.

Make sure that all the lights in the same Light Group.

Turn All the Lights ON

- Turn the Radio Controller On
- Use the arrow keys to adjust the operational Mode to ON
- Press [MENU] button once to reach Light Group
- Set the Light Group to ALL
- Press [SEND] button
- Every radio light within range of the control unit will now turn on.

Setup the Lights to Operate in DUSK till DAWN mode

- Turn the Control unit On
- Use the arrow keys to adjust the operational Mode to DUSK till DAWN
- Press [MENU] button once to reach Light Group
- Set the Light Group to ALL
- Press [SEND] button
- Every radio light within range of the control unit will now turn on at night, during the day the lights will turn off automatically.

Runway B Only is to be HIGH Intensity, but Runway A will Remain in Current Configuration

- On Runway A, set the light group to 0 (follow the instruction in Section 2 in the 'Radio Control System Setup' section of this manual).
- On Runway B, set the light group to 1 or any group different to Runway A.
- Turn the Control unit On
- Use the arrow keys to adjust the operational Mode to Always On
- Press [MENU] button to reach Light Group
- Set the Light Group to 1
- Press [MENU] button to reach LED Intensity
- Use the arrow keys to adjust the LED Intensity to HIGH
- Press [MENU] button to reach Advanced Operation Mode
- Use the arrow keys to select Visible LEDs
- Press [SEND] button
 - Runway A will not change state.
 - Runway B will now be High Intensity.

Runway B Only is to be HIGH Intensity, with a Timeout of 8 Minutes and Runway A will be I/R Low Intensity

- On Runway A, set the light group to 0.
- On Runway B, set the light group to 1.
- Turn the Control unit On
- Use the arrow keys to adjust the operational Mode to Always On
- Press [MENU] button to reach Light Group
- Set the Light Group to 1
- Press [MENU] button to reach LED Intensity
- Use the arrow keys to adjust the LED Intensity to HIGH
- Press [MENU] button to reach Timeout Mode
- Use the arrow keys to adjust the Timeout Mode to Enabled LOW
- Press [MENU] button to reach Timeout Duration
- Use the arrow keys to adjust the Timeout Duration to 8 Minutes
- Press [SEND] button
 - Runway A will not change state.
 - Runway B will now be High Intensity. After 8 minute Runway will revert back to LOW intensity.
- Press [MENU] button until you reach Light Group
- Set the Light Group to 0
- Press [MENU] button once to reach LED Intensity



-
- Use the arrow keys to adjust the LED Intensity to LOW
 - Press [MENU] button to reach Advanced Operation Mode
 - Use the arrow keys to select IR/NGV LEDs
 - Press [SEND] button
 - Runway A will be in LOW Intensity IR mode
 - Runway B will not change state. Lights on Runway B will still receive and pass on the message intended for Runway A.

7.0 Maintenance and Servicing

Designed to be almost maintenance-free, the AV-426 requires minimal attention, though the following maintenance and servicing information is provided to help ensure the life of your Avlite Systems product.

1. **Cleaning Solar Panels** - occasional cleaning of the solar panels may be required. Using a cloth and warm soapy water, wipe off any foreign matter before rinsing the panels with fresh water.
2. **Battery Check** - inspection of batteries should be performed every three years (minimum) to ensure that the charger, battery and ancillary electronics are functioning correctly. Using a voltage meter, check that the battery voltage is at least 12 volts under 100mA load, and ensure all terminals are clear of foreign matter.
3. **O-Ring Check** - inspect the condition of the O-ring for damage, wear or if it is brittle, and replace if necessary. The O-ring should be a rubber texture to ensure a complete and even seal.

Service Tools

- 1 x M2 Allen Key
- 1 x M5 Allen Key
- 1 x 13mm Combination Wrench
- 1 x M8 Allen Key
- 1 x 10mm Combination Wrench
- 1 x Silicone Grease

Replacement Part Numbers

Complete Units (For Example):

- AV-426-ICAO-C0-W-01
- AV-426-ICAO-C2-WY-01
- AV-426-861-C0-W-01
- AV-426-861-C2-GY-01
- AV-426-861E-C0-RG-01
- AV-426-861E-C2-R-01

Light Head only (For Example):

- AV-LA426-ICAO-WY-01
- AV-LA426-861-GY-01
- AV-LA426-861E-R-01

Solar Unit Only:

- AV-SBA425

Battery Charger (12 volt):

- AV-BTC-SLA-12V-2P

Solar Booster™:

- AV-SB-10-Y



AV-426 Long Term Battery Storage & Maintenance

If the AV-426 is to be placed in storage for an extended period please follow the below information.

The Sealed Lead Acid batteries inside the lights must always be stored in a fully charged state.

Always make sure the ON/OFF switch is in the OFF position.

All batteries will discharge over time and the rate of discharge is dependent on temperature.

If the light is being stored in temperatures greater than 40°C the battery will discharge faster.

Please check battery regularly and recharge if necessary, charge the battery via the external charging port on the base of the unit. Only attach the plug with your hand, do not use multi-grips to attach the plug.

Turn the ON/OFF switch to the ON position and place unit in the sun for 2-4 days.

The AV-426 is fitted with a 12 volt charge port that can be used to charge the battery and test the battery voltage.

Installing the Light Head Assembly on the Solar Unit

After servicing, it will be necessary to reinstall the light head on the solar unit.

1. Connect the 4 bullet connectors
2. Ensure the O-ring seal on the top of the solar chassis is in place, clean and lightly greased
3. Feed the wires into the corner of the solar unit
4. Locate the light head onto the solar unit in the correct orientation to the runway. The light head is fitted with reflective tape indicators to show light output. This colour indication should be aligned with the colour indication on the solar unit to ensure correct alignment.
5. Fit the 4 x M6 x 20 SHCS
6. Tighten the SHCS evenly and firmly.

It is recommended that the bolts for holding the light heads to the Solar Base units have a torque setting applied of 3Nm for a satisfactory seal.

Applying a higher Torque setting is not recommended and may void warranty. If in doubt, please contact your local Avlite representative.

7. Remove all tools, nuts and bolts from the runway

Replacing the Battery

The AV-426 has an internal battery compartment, which provides the user with the ability to change the battery after years of operation.

1. Remove the four socket-head screws on the top lens assembly and separate the AV-426 lens assembly from the body/base section.
2. Remove 2 x M2 SHCS & washers from the top battery bracket.
3. Separate the light head at the connectors.
4. Lift the upper battery bracket out of the AV-426.
5. Disconnect the old battery
6. Remove the old battery from the chassis.
7. Discard old battery in a safe manner.
8. Reconnect the new battery.
9. Place battery back inside light body, and position the upper battery bracket in the top of the chassis.
10. Secure using 2 x M4 Cap screws & washers.
11. Feed all wiring back inside light body, and make sure the O-ring is properly placed at the top of the light body.
12. Please realign bidirectional indicators on the base with the light head to ensure correct alignment of the light output on the runway.
13. Place the top lens assembly back onto the light body and replace 4 socket head screws. Half tighten all 4 socket head screws, and then fully tighten each socket head screw to ensure an even seal.

It is recommended that the bolts for holding the light heads to the Solar Base units have a torque setting applied of 3Nm for a satisfactory seal.

Applying a higher Torque setting is not recommended and may void warranty. If in doubt, please contact your local Avlite representative.

14. To test place dark cover (towel or jacket) on top of light to activate sensor, light will come on.

**Care must be taken to observe the polarity of each wire before they are connected.
To ensure waterproofing of the unit, make sure that there is an even seal.**

Safe Battery Handling

Charging and Discharging

- Always ensure batteries are fully charged when installing new lights. The light will be dispatched from the Avlite factory fully charged. However if time has elapsed between dispatch and installation, battery voltage must be checked.
- Never short-circuit or reverse polarity of a battery, damage to the battery and device may occur, and there is a risk of fire.
- Do not use different types of batteries in the same battery assembly. Sealed lead acid and NIMH do not mix.
- If the battery has been deep-discharged, a prolonged charging time is required to bring the battery back to full capacity.



Storage

- Always store batteries in a cool, dry place.
- After long storage, it is desirable to cycle (charge/discharge) the battery 3 times to restore full capacity.
- Do not mix batteries with metal objects during storage or transportation to avoid accidental short-circuit.
- Do not store large quantities of batteries in a densely packed condition when they are in a charged or partially charged state.

Battery Handling

- Do not incinerate or dismantle batteries. Cell components are corrosive and may be harmful to skin and eyes.
- Do not pull on battery lead wires or connector. Excessive force on the leads or connectors can damage the welding joints or other connections.
- Batteries are recyclable. Please dispose of properly.

Battery Voltage States of Charge

Avlite has provided the following guides for battery states of charge:

Battery Voltage: 12 Volt Sealed Lead Acid	
State of Charge	Voltage
100%	12.70+
90%	12.5
80%	12.42
70%	12.32
60%	12.2
50%	12.05
40%	11.9
30%	11.75
20%	11.58
10%	11.31
0%	10.5

8.0 Trouble Shooting

Fault	Possible Cause	Remedy
Light will not respond to controller in Radio Control Mode	Refer to AvMesh™ RF Communications System Installation and Trouble Shooting Manual, available under the AV-426 Downloads section.	
Light will not change between visible and IR/NVG modes	Advanced Operation not enabled	Enable Advanced operation Mode in the Radio Control System Menu. See Programming - Section 1
Light will not change Flash Codes	Flash Codes not enabled in the Radio Control System Menu	Enable Flash Codes in the Radio Control System Menu. See Programming- Section 1
Sync delay not available	Sync not enabled in the Radio Control System Menu	Enable Sync in the radio Control Menu. See Programming- Section 1
Light will not activate	Light is not switched ON at the master switch	Switch light on at the Red Master Switch on the I/O panel
	Battery is flat	Recharge Battery or connect light to external power supply
Lights will not activate during the Day	Light is set to Dusk till Dawn and it is not dark	Cover the light for at least 60 seconds of continuous darkness for the light to activate To activate lights during the day, temporarily change the light settings to Always On. Important: Lights must be turned back to Dusk till Dawn or Standby after required daytime use.



Fault	Possible Cause	Remedy
Light will not activate at night	Light is not switched on at the master switch	Switch light on at the Red Master Switch on the I/O panel
	Light is in Standby Mode	Using the Remote control change light to the Dusk till Dawn
Light will not operate all night	Light is exposed to ambient light Battery is low	Remove ambient light source or shield light from ambient light Recharge battery, connect battery to external power supply or replace battery
	Battery is low	Recharge battery, connect battery to external power supply or replace battery
	Requested operation is greater than solar charge can support	Consult an Avlite representative or email info@avlite.com for solar calculations to verify maximum usage profile
Battery continually goes flat	Battery has failed	Replace battery
	Solar panels are dirty	Clean solar panels
	Light is installed in the shade	Remove shade or move light fixture

9.0 Documentation

For future reference, please record the following data and store securely:

Controller Encryption Key: _____

Controller Serial No.: _____

Radio Channel: _____

Light Bank Location, eg. Runway 1, Taxiway, Runway 2:

Light Bank Location 0: _____

Light Bank Location 1: _____

Light Bank Location 2: _____

Light Bank Location 3: _____



10.0 AV-SB Solar Booster™

The AV-SB-10 Solar Booster™ can be connected to AV-426 light to provide additional solar collection to charge the battery. The Solar Booster™ can be used in areas of reduced sunlight to help ensure optimum battery charge or where longer periods of high intensity mode is required.

The solar panel is connected to the light via the external charge port and the panel is mounted at an angle to maximise solar collection during daylight hours.

The solar Booster™ will provide up to 0.5Ah of additional charge into the battery.

In areas of high solar conditions, this may allow the fixture to operate in a high-intensity L-861 output setting for up to 11hrs per night.

In lower solar regions, fitting the Solar Booster™ may widen the operating latitudes where the standard AV426 may not be sufficient.

For detailed solar profiling of your region please contact Avlite Systems.

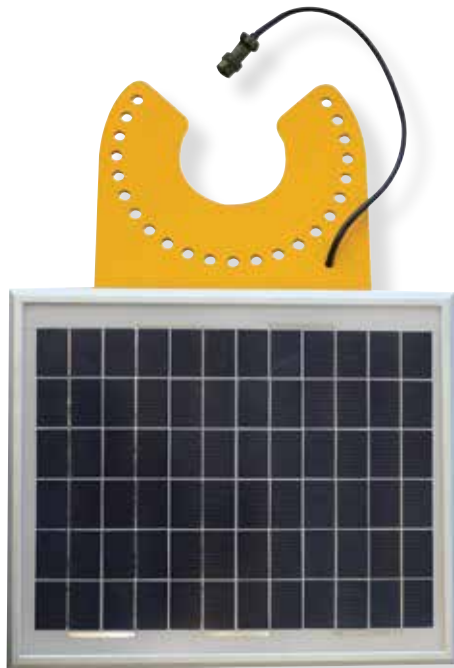

10.1 Solar Booster™ Installation Procedure

Preferred Installation Location

For best light performance, ensure solar modules are not covered and are in clear view of the sky with no shadows.

Remove the AV-SB from the box and remove all packaging.

Locate the AV-SB Solar Booster™, in a position for best solar collection.

Remove the bolts from the existing installation. Fit the AV-SB Solar Booster™ under the top mounting plate. Fit the bolts back through the light, mounting plate and AV-SB Solar Booster™. Tighten the bolts securely.

Important: To eliminate the possibility of electrical shorts please read this before connecting the AV-SB-10 Solar Booster™ to the light

Remove the Light head from the unit. Remove the fuse from the battery positive wire.

Connect the AV-SB-10 Solar Booster™ to the external charge port on the light.

Refit the fuse to the battery positive wire and refit the light head.

Cover the light head to ensure that light activates.

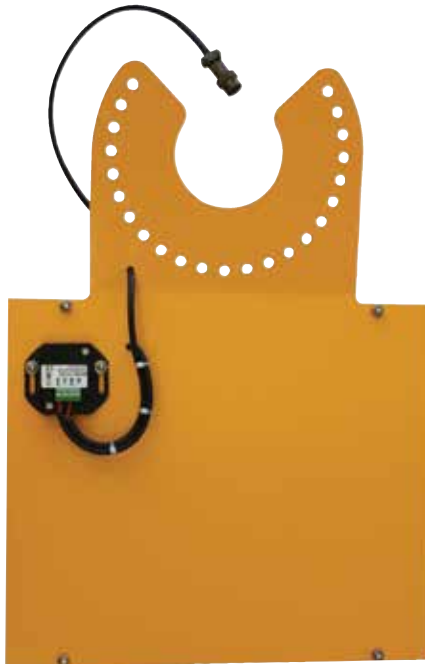



Notes

Avlite Solution Verticals available



Airfield



Heliport



Obstruction



We believe technology improves navigation™

avlite.com info@avlite.com

Avlite Systems
Australia
+61 (0)3 5977 6128

Avlite USA LLC
USA
+1 (603) 737 1311

Avlite Asia Pte Ltd
Singapore
+65 6908 2917