

Solar Powered ICAO Type A Low Intensity Obstruction Light



AV-OL-75



- Solar powered, self-contained
- Convenient servicing via your phone or tablet
- Dual internal high-performance solar modules
- Smallest and lightest self-contained ICAO compliant LIOL Type A Obstruction Light
- Easy installation
- Tough UV-stabilised LEXAN® polycarbonate lens and light base

Features

- Integrated solar/battery system
- Dual internal high-performance solar modules angled to maximize solar collection
- Save time, maintenance costs and increase safety by maintaining the light without leaving the ground
- Conveniently check the battery
- Fast & easy to deploy - no programming
- Ultra-high intensity LED (no changing globes ever)
- IP68 waterproof rating
- User-replaceable battery

Applications

- Wind Turbine
- Crane
- Buildings
- Towers

Compliance

Low Intensity Type A Obstruction Light, ICAO Annex 14, Volume 1, Sixth Edition, July 2013, 'Aerodrome Design and Operations'

The AV-OL-75 is a next generation, low maintenance, self-contained solar LED obstruction light designed to comply with ICAO LIOL Type A requirements. The model is suitable for a variety of applications including telecommunication towers, wind turbines, buildings and other structures up to 45 meters.

Manufactured using the latest in LED technology, the AV-OL-75 is an ultra bright, energy efficient and cost effective self-contained solar obstruction light with Bluetooth® connectivity for convenient servicing via your phone or tablet.

Bluetooth® for Monitoring

Convenient servicing via the new Bluetooth® connected AvlitePro™ mobile application, the AV-OL-75 can be monitored from a distance up to 50 meters. An in-built solar calculator confirms the lights ability to operate at the set location, ensuring optimal operating performance.

Dual High Performance Solar Modules

The AV-OL-75 boasts dual high performance solar modules which are tilted to obtain maximum sunlight capture, allowing the unit to operate reliably in a range of low sunlight environments. Utilizing the two in-built, high performance integrated panels to charge the battery during daylight hours and the internal photo diode to detect ambient light to achieve a true self-sufficient dusk-till-dawn operation.

Small Form Factor

The small form factor of the AV-OL-75 makes it the smallest and lightest self-contained ICAO compliant LIOL Type A obstruction light in the market. The new lights are compact, rugged and come fully self-contained. They offer rapid and easy installation due to the fact there is no external cabling or power required.

Optional GSM Monitoring

The AV-OL-75 may also be fitted with GSM Cell-Phone Monitoring-enabling users to access real-time diagnostic data. The system can also be configured to send out alarm SMS text messages or email alerts to designated operators should alarm conditions be triggered, such as low voltage or light failure.



AUSTRALIA
t: +61 (0)3 5977 6128

USA
t: +1 (603) 737 1310

w: www.avlite.com
e: info@avlite.com

SPECIFICATIONS • AV-OL-75

Light Characteristics

Light Source	1 LED
Available colors	Red as standard.
Minimum Intensity (cd)†	10 cd - ICAO Type A
Available Operation Modes	Stand by, steady-on, dusk till dawn
LED Life Expectancy (hours)	>100,000

Electrical Characteristics

Operating Voltage (V)	3.6
Temperature Range	-40 to 80°C

Solar Characteristics

Solar Module Type	Monocrystalline
Output (watts)	2 x 2.5 watt
Charging Regulation	Microprocessor controlled

Power Supply

Battery Type	High grade NiMH - Environmentally friendly
Battery Capacity (Ah)	21.5
Nominal Voltage (V)	3.6
Autonomy (nights)	Steady-on: 19 nights (14 hour nights)

Physical Characteristics

Body Material	LEXAN® Polycarbonate - UV stabilized
Lens Material	LEXAN® Polycarbonate - UV stabilized
Lens Diameter (mm/inches)	140 / 5½
Lens Design	TIR
Mounting	6 x 17mm holes on 200mm PCD
Height (mm/inches)	341 / 13 7/8
Width (mm/inches)	231 / 9 1/8
Mass (kg/lbs)	2.6 / 5 5/8
Product Life Expectancy	12 years plus

Environmental Factors

Humidity	0 to 100%, MIL-STD-810F
Icing	21.9kg per square cm / 48.5lbs per square inch
Wind Speed	Up to 160kph / 100mph
Shock	MIL-STD-202G, Test Condition G, Method 213B
Vibration	MIL-STD-202G, Test Condition B, Method 204

Certifications

CE	EN61000-6-3:2007 EN61000-6-1:2007
Quality Assurance	ISO9001:2015
ICAO	Low Intensity Obstruction Light Type A - 2013
Waterproof	IP68

Intellectual Property

Trademarks AVLITE® is a registered trademark of Avlite Systems

Warranty *

5 year warranty

Options Available

- GSM Monitoring
- External ON/OFF Switch
- External Battery Charging Port

Disclaimer

Bluetooth connectivity can be subject to site specific conditions & device receiver quality.

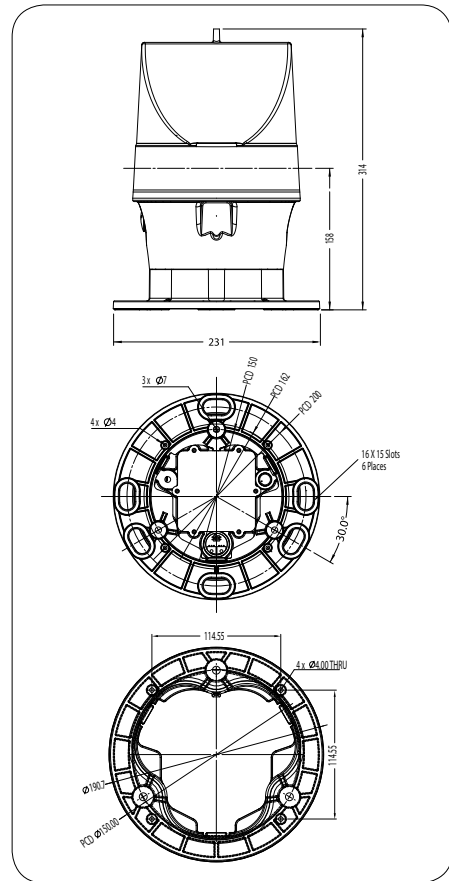

AvlitePro™ mobile application provides Battery, Autonomy and Power data.

