



AV-WC-L

Solar Powered Lighted Windsock Assembly Installation & Service Manual

AV-WC-L

Solar Powered Lighted Windsock Assembly

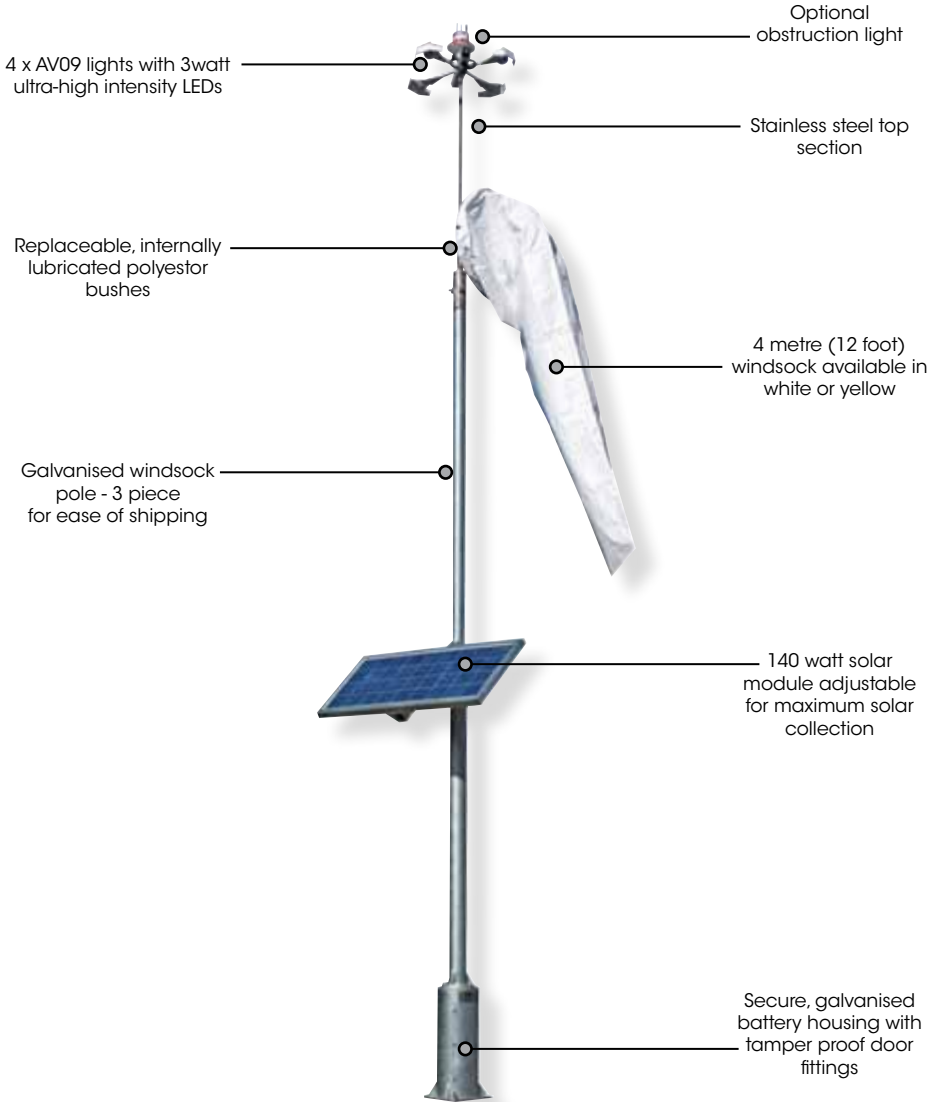

Table of Contents

Introduction	4
Operating Principle	4
Technology	4
AV-WC-L Model	5
Assembly & Installation	6
Installing the solar panel into the lighting frame	6
Installing the solar panel mounting frame on the pole.....	6
Installing the windsock frame on the pole.....	7
Installing the lighting hub on the pole	7
Assembling the windsock pole	8
Mounting the windsock pole	9
Connecting the wiring & installing the batteries.....	9
Regulator Connection & Operation	10
Regulator Connection Order.....	10
Selecting Lighting Control Option	10
Day/Night Transition	11
LED Indicators	11
Maintenance & Servicing	12
Trouble Shooting	13
Avlite Light Warranty	14

Version No.	Description	Date	Approved
1.0	Manual Launch	August 2011	M. Henry
2.0	Updated spec table	January 2013	J. Dore



Introduction

Congratulations! By choosing to purchase an Avlite light, you have become the owner of one of the most advanced solar LED airfield lights in the world.

Avlite Systems draws on more than 25 years experience in the design and manufacture of navigation aids, and particular care has been taken to ensure your light gives years of trouble free service.

As a commitment to producing the highest quality products for our customers, Avlite has been independently certified as complying with the requirements of ISO9001:2008 quality management system.

By taking a few moments to browse through this booklet, you will become familiar with the versatility of your light, and be able to maximise its operating function.

Please remember to complete the Avlite warranty registration card accompanying your light.

Operating Principle

The solar module of the light converts sunlight to an electrical current that is used to charge the battery. The battery provides power to operate the light at night.

The flasher unit has very low current requirements. A microprocessor drives an array of ultra bright LED's through a DC/DC converter, which enables the LED's to operate within the manufacturer's specifications. The battery is protected from over-charging within the circuit to ensure maximum battery life.

On darkness, the microprocessor will initiate a program check and after approximately 1 minute will turn on.

Technology

Avlite Systems is a world-class solar lighting systems manufacturer with a proven reputation for rapid, innovative, and agile technology solutions designed specifically for defense, government, civil and humanitarian aid operations in the most remote, toughest environments.

Electronics

Avlite employs leading in-house electronic engineers in the design and development of software and related circuitry. All individual electronic components are sourced directly by Avlite procurement staff ensuring that only the highest quality components are used in our products.

LED Technology

All aviation lights use the latest advancements in LED (Light Emitting Diode) technology as a light source. The major advantage of LED's over traditional light sources is well established in that they typically have an operational life in excess of 100,000 hours, resulting in substantial savings to maintenance and servicing costs.

Precision Construction

Commitment to investing in the design and construction of injection-moulded parts including optic lenses, light bases and a range of other components ensures that all Avlite products are of a consistent and superior quality.

Optical Performance

Avlite manufactures a range of aviation LED lenses moulded from multi-cavity dies. Complex shapes such as the AV70 and 16-segment multi-focus lenses are a testament to the company's superior in-house lens manufacturing capabilities and outstanding optical performance.

Award-winning, Patented Technology

Several United States and Australian patent registrations are held on Avlite's range of innovative designs, with other regional patents pending in Canada, United Kingdom and Europe.

AV-WC-L Model

The AV-WC-L solar powered lighted windsock assembly is designed for use around helipads and aerodromes requiring a complete solar powered lighting solution. The 4 x AV09 light source is powered by 2 x 55Ahr SLA batteries and is recharged during the day by a 140watt solar module. A quality 10 amp solar controller ensures the batteries are fully charged and to protect the batteries from over charging.

The AV-WC-L is a fully self contained unit requiring no external power supply or expensive under ground cabling, making this a cost effective and efficient installation option. The AV-WC-L includes pole, lighting, 12 ft windsock, batteries, solar panel and solar regulator.

SPECIFICATIONS* *

AV-WC-L

Light Characteristics

Light Source

4 x domed luminaires each with 1x 3watt ultra-high intensity surface-mounted LED

Available colors

White

LED Life Expectancy (hours)

>100,000

Electrical Characteristics

Circuit Protection

Polarity protected

Operating Voltage (V)

12

Temperature Range

-40 to 80°C

Solar Characteristics

Solar Module Type

Multicrystalline

Output (watts)

140

Solar Module Efficiency (%)

15

Charging Regulation

Controller

Power Supply

Battery Type

SLA (Sealed Lead Acid)

Battery Capacity (Ah)

2 x 55Ah

Nominal Voltage (V)

12

Autonomy (nights)

8

Physical Characteristics

Mounting (post)

4 x 22mm holes

Height (mm/inches)

240 / 529

Mass (kg/lbs)

Up to 12 years

Product Life Expectancy

Certifications

CE

EN61000-6-3:1997. EN61000-6-1:1997

Quality Assurance

ISO9001:2008

Intellectual Property

Trademarks

AVLITE® is a registered trademark of Avlite Systems

Warranty *

3 year warranty

Options Available

- Radio controlled
- Avlite Pilot Activated Lighting Control
- External ON/OFF Switch
- Solar powered obstruction light

* Specifications subject to change or variation without notice

* Subject to standard terms and conditions



Assembly & Installation

Installing the solar panel into the mounting frame

1. Generally your AV-WSC will be shipped with the solar panel already installed. However in the event that the solar panel requires replacement fix the solar panel to the frame using M8 x 20 bolt, flat washers and Nylock nuts in 4 places.

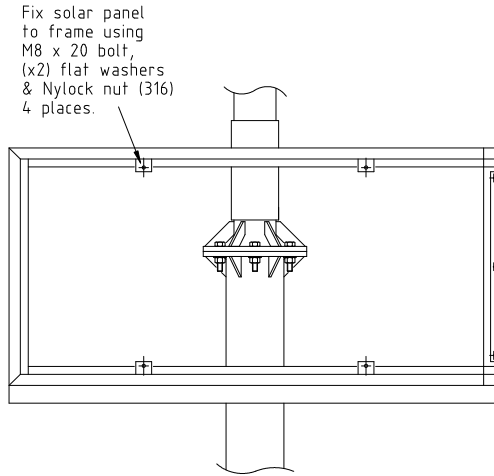

Installing the solar panel mounting frame on the pole

1. Back off the locking screws on the solar panel mount
2. Feed the solar panel mount over the middle section of the AV-WSC pole and slide all the way down to the pole mounting flange.
3. The solar panel mounting frame is designed to rest on the gussets from the mounting flange.
4. Feed the solar panel cable into the cable gland at the base of the middle pole section.
5. Allow enough cable for the solar array to be rotated enough to be located toward the sun after installation of the pole.
6. Tighten the locking screws to prevent the solar array from turning.

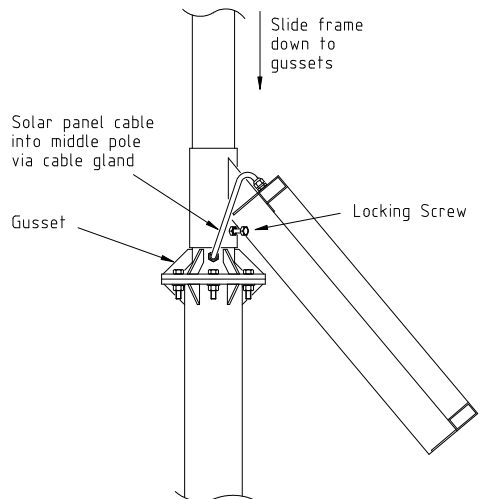

Installing the windsock frame on the pole

1. Fit the windsock spacer on to the windsock pole top section and slide all the way down the pole. Place a small bead of silicone around the mating surfaces of the spacer and the weld joint of the top section mounting flange. The spacer is not designed to rotate.
2. Fit the windsock bushes to the windsock frame and fit the frame onto the the top section pole.
3. Fit the locking collar to the top section pole and slide down to the windsock frame. Allow 4mm of Vertical free play and tighten the locking collar in place.
4. Using heavy duty UV stabilised cable ties fix the windsock to the windsock frame. Place a cable tie either side of the metal lugs on the windsock frame. This stops the windsock from moving on the frame.

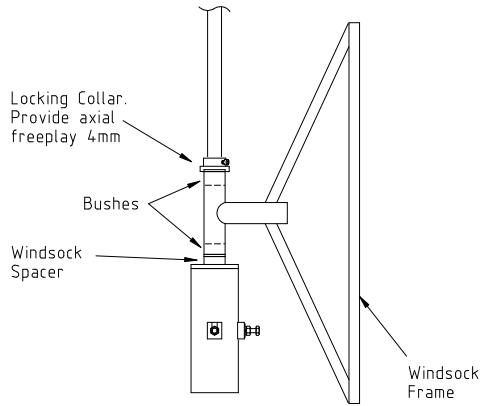

Installing the lighting hub on the pole

1. Connect the power cable to the junction box
2. Carefully slide the lighting hub over the top section of the pole. Ensure the cable is sitting in the slot. Do not crush the wire.
3. After sliding the lighting hub on to the pole as far as it will go, ensure the locking screws are not located over the cable and tighten securely.
4. Fit windsock post cap on top and tighten with locking screws

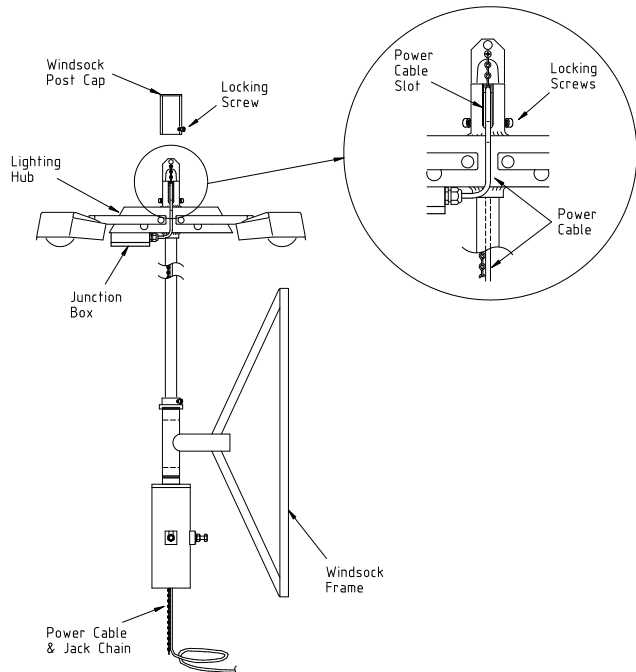

Assembling the windsock pole

1. The windsock pole is assembled from the top down.
2. Feed the wires from the top section down into the middle section of the pole.
3. Slide the base of the top section over the top of the middle section and tighten the locking screws securely
4. Feed the wires now hanging out the base of the middle section into the lower section, along with the cable from the solar panel.
5. Using a suitable silicone sealant, place a bead of silicone around the flange of the lower pole section, just inside the mounting holes.
6. Fit the lower section of the pole and the middle section together and torque the bolts to the correct torque of 83Nm.
7. Feed the cables now hanging out the bottom of the lower section into the battery cavity.
8. Using a suitable silicone sealant, place a bead of silicone around each of the bolt holes and around the inside of the mounting holes.
9. Fit the pole lower section and the battery housing together. Fit the washers under the head of the bolt and place more silicone sealant under the washers to prevent any water getting into the battery housing.
10. Torque the bolts to the correct torque of 200nm.

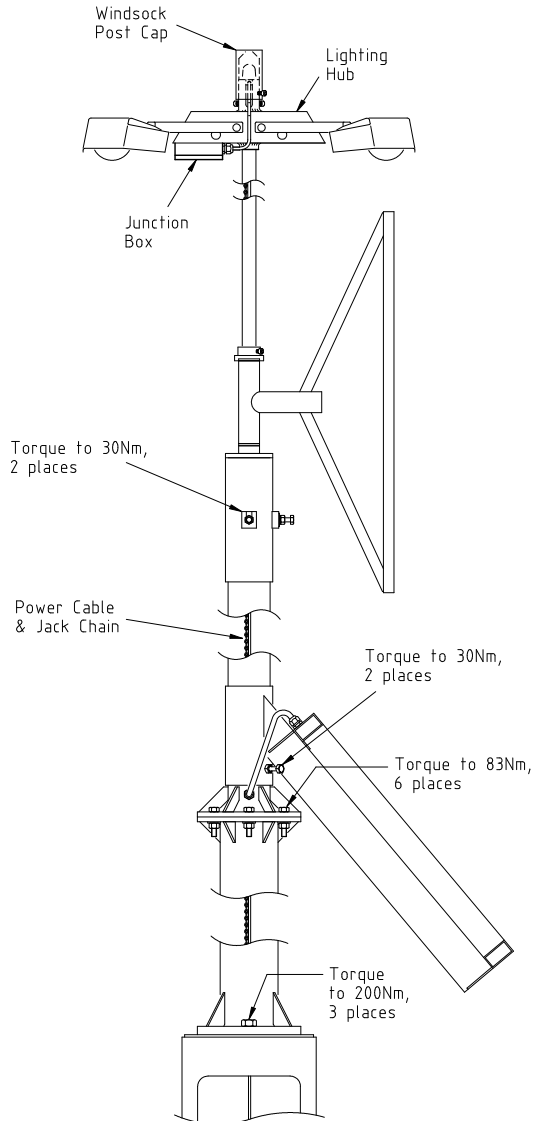



Mounting the Windsock pole



This should only be attempted by persons with extensive experience in lifting and crane operation.

1. The following safety points must be followed:
 - Carefully sling the middle section of the Windsock pole.
 - Care should be taken that the slings will not slip up the pole
 - Use only tagged slings that are rated for the job.
 - Care should be taken to ensure that all bystanders are safely out of the way.
 - Care should be taken not to smash the solar panel or the light hub.
 - Care should be taken not the place any load on the windsock swivel frame.
 - Windsock assembly should NEVER be lifted by the top section.
2. Carefully lift the windsock assembly into location and bolt done securely.
3. Secure the nuts on the mounting base flange so they can't be removed by vandals. Do not weld the nuts to the studs-This will damage the sensitive electronics parts in the lighting system. Concrete over the nuts or burr over the threads with a cold chisel so the nuts can't be removed easily.

Connecting the wiring and installing the batteries

1. Follow the directions on the solar regulator for the correct connection sequence. See 'Regulator Connection & Operation' section of this manual.
2. Connect the battery terminals first. It is recommended to assemble all electrical connections with marine grease, to prevent corrosion.
3. Connect the Solar panel connections next.
4. Finally connect the light hub to the load section of the solar Regulator.
5. Set the timer on the solar controller to the required setting. Standard is dusk till dawn.
6. If the windsock light is fitted with RF Control, PALC or Manual ON/OFF switch the lighting cable will be connected directly to the battery. Connect the brown battery positive wire to the battery positive terminal on the battery and the blue battery negative wire to the battery negative terminal. Care should be taken NOT to short out any of the battery terminals on the battery housing.

Regulator Connection & Operation

Regulator Connection Order

The label on the Regulator has each system connection labelled from 1 to 6. This is the recommended order of system connections.

IMPORTANT: The BATTERY must be connected before the SOLAR to properly start the microcontroller.

1. BATTERY: Connect the battery (+) and battery (-) to the Regulator
2. SOLAR: First, be certain the battery (+) and battery (-) is connected correctly. Then connect the solar array to the SOLAR terminals.

Selecting Lighting Control Option

After completing the system connections, select the desired LIGHTING CONTROL option.

A brief description is as follows:

- | | |
|----------------|--|
| OFF | Lights remain turned off |
| 2, 4, 6, 8, 10 | Hours light is turned off after sundown |
| 3/1, 4/2, 6/2 | Light is turned on after sundown, turned off during the night, and turned on again one hour (3/1) or two hours (4/2, 6/2) before sunrise |
| D/D | Dusk-to-Dawn, light is on all night |

The factory setting of the light is D/D (Dusk-to-Dawn).

To select a lighting option, turn the rotary digital switch to the desired position. An arrow in the rotary switch will point to the selected position. This is a digital switch, so it will click into each of the ten positions.

To confirm correct selection of the desired control option, press the TEST button located below the rotary switches.

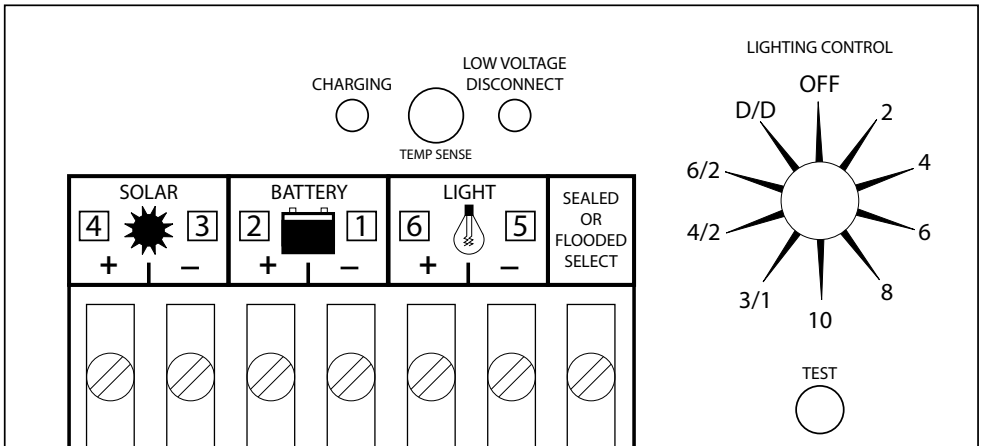

Regulator Diagram



Day/Night Transition

The Regulator uses the solar array to detect day and night. The transition to night requires the level of solar radiation being received to be less than 2 percent. The transition back to day requires a high solar array open-circuit voltage. Both state changes require 10 minutes of continuous transition values before making change. These constraints avoid false transitions due to lightning or dark storm clouds.

LED Indicators:

Green LED

The green LED indicator will light whenever sunlight is available for battery charging. The green LED will turn off at night.

Because the Regulator uses a PWM constant voltage charging process, there is usually some amount of energy going into the battery at all times. Although the charging current falls to very low levels when the battery reaches full charge, the green LED will continue to stay ON all day. This is to indicate that the controller is working and that energy is available from the PV array for charging.

Red LED

The red LED is an indicator for 3 different functions:

- Automatic low voltage load disconnect (LVD)
If the battery charge state falls below the LVD setpoint, the light will be disconnected and the red LED will light. This indicates the controller has disconnected the load to protect the battery from further discharge and possible damage. The red LED will turn off when the battery recovers to about 50% of its rated capacity and the load is automatically reconnected.
- Initial controller start-up
When the regulator is properly connected to the battery, the red LED will flash 3 times.
- Confirm lighting control selection
When the TEST button is pressed, the red LED will confirm the lighting control option selected by the rotary switch.



Maintenance and Servicing

General Maintenance

1. Inspect the mounting bolts for evidence of tampering or corrosion
2. Clean bird droppings and debris from the solar panel.
3. Inspect the windsock for signs of wear or damage- Replacement windsocks are available from Avlite.
4. Check the battery voltage. This should be done at sunrise. Batteries with low battery voltages should be replaced.

Battery Replacement

1. Batteries may require replacement of replacement batteries are available from Avlite
2. Use batteries of the same size.
3. Both batteries must be replaced at the same time.

Windsock replacement

1. Replacement windsocks are available from Avlite
2. Use UV stabilised heavy duty cable ties to mount the windsock.

Trouble Shooting

Problem	Remedy
Lights fail to activate	<ul style="list-style-type: none"> • Ensure battery connections are correct polarity • Ambient light is above threshold. Ensure lantern is in darkness • Ensure battery terminals are properly connected • Ensure battery voltage is above 12volts • Battery is flat - recharge or replace batteries • Solar regulator is faulty
Light will not operate for the entire night.	<ul style="list-style-type: none"> • When the lantern is initially removed from storage the battery may be discharged and require several days of operational conditions to 'cycle' up to full autonomy. Expose lantern to direct sunlight and monitor operation for several days. Avlite products typically require an average 2.5 hours of direct sunlight per day to retain full autonomy. • Ensure solar module is clean and not covered by shading during the day. • Do not cover module with protective devices such as a steel cage as small shadows across cells reduce performance. • Batteries slowly lose capacity over time. Failure to operate for the full night may be the result of loss of capacity which means the battery must be replaced.
Batteries are flat	<ul style="list-style-type: none"> • Solar panel is faulty - replace solar panel • Solar regulator is faulty - replace regulator • Solar panel is in shade - remove object causing shade • Batteries require replacement - replace batteries
Windsock fails to turn	<ul style="list-style-type: none"> • Grit or dirt is in the bushes - clean and relubricate bushes • Obstruction is preventing the windsock from turning - remove obstruction



Avlite Light Warranty V1.1

Activating the Warranty

Upon purchase, the Avlite Systems warranty must be activated for recognition of future claims. To do this you have two (2) options:

1. **Postal Registration**

Please complete the Avlite Systems Warranty Registration Card and return to Avlite within 30 days of your purchase.

2. **Online Registration**

Please complete the Online Registration Form at; www.avlite.com

Avlite Systems will repair or replace your lantern in the event of electronic failure for a period of up to three years from the date of purchase.

The unit must be returned to Avlite freight prepaid.

Warranty Terms

1. Avlite Systems warrants that any Avlite aviation products fitted with telemetry equipment including but not limited to AIS, GSM, GPS or RF ("Telemetry Products") will be free from defective materials and workmanship under normal and intended use, subject to the conditions hereinafter set forth, for a period of twelve (12) months from the date of purchase by the original purchaser.
2. Avlite Systems warrants that any rotationally-moulded products ("Roto-Moulded Products") and accessory products ("Accessory Products") will be free from defective materials and workmanship under normal and intended use, subject to the conditions hereinafter set forth, for a period of twelve (12) months from the date of purchase by the original purchaser.
3. Avlite Systems warrants that any Avlite aviation products other than the Telemetry Products, Roto-Moulded Products and Accessory Products ("Avlite Products") will be free from defective materials and workmanship under normal and intended use, subject to the conditions hereinafter set forth, for a period of three (3) years from the date of purchase by the original purchaser.
4. Avlite Systems will repair or replace, at Avlite's sole discretion, any Telemetry Products, Roto-Moulded Products, Accessory Products or Avlite Products found to be defective in material and workmanship in the relevant warranty period so long as the Warranty Conditions (set out below) are satisfied.
5. If any Telemetry Products or Avlite Products are fitted with a rechargeable battery, Avlite Systems warrants the battery will be free from defect for a period of one (1) year when used within original manufacturer's specifications and instructions.

Warranty Conditions

This Warranty is subject to the following conditions and limitations;

1. The warranty is applicable to lanterns manufactured from 1/1/2009.
2. The warranty is void and inapplicable if:
 - a. the product has been used or handled other than in accordance with the instructions in the owner's manual and any other information or instructions provided to the customer by Avlite;
 - b. the product has been deliberately abused, or misused, damaged by accident or neglect or in being transported; or
 - c. the defect is due to the product being repaired or tampered with by anyone other than Avlite or authorised Avlite repair personnel.
3. The customer must give Avlite Systems notice of any defect with the product within 30 days of the customer becoming aware of the defect.
4. Rechargeable batteries have a limited number of charge cycles and may eventually need to be replaced. Typical battery replacement period is 3-4 years. Long term exposure to high temperatures will shorten the battery life. Batteries used or stored in a manner inconsistent with the manufacturer's specifications and instructions shall not be covered by this warranty.



5. No modifications to the original specifications determined by Avlite shall be made without written approval of Avlite Systems.
6. Avlite lights can be fitted with 3rd party power supplies and accessories but are covered by the 3rd party warranty terms and conditions.
7. The product must be packed and returned to Avlite Systems by the customer at his or her sole expense. Avlite Systems will pay return freight of its choice. A returned product must be accompanied by a written description of the defect and a photocopy of the original purchase receipt. This receipt must clearly list model and serial number, the date of purchase, the name and address of the purchaser and authorised dealer and the price paid by the purchaser. On receipt of the product, Avlite Systems will assess the product and advise the customer as to whether the claimed defect is covered by this warranty.
8. Avlite Systems reserves the right to modify the design of any product without obligation to purchasers of previously manufactured products and to change the prices or specifications of any product without notice or obligation to any person.
9. Input voltage shall not exceed those recommended for the product.
10. Warranty does not cover damage caused by the incorrect replacement of battery in solar lantern models.
11. This warranty does not cover any damage or defect caused to any product as a result of water flooding or any other acts of nature.
12. There are no representations or warranties of any kind by Avlite or any other person who is an agent, employee, or other representative or affiliate of Avlite, express or implied, with respect to condition of performance of any product, their merchantability, or fitness for a particular purpose, or with respect to any other matter relating to any products.

Limitation of Liability

To the extent permitted by section 68A of the Trade Practices Act 1974 (Cth), the liability of Avlite Systems under this Warranty will be, at the option of Avlite Systems, limited to either the replacement or repair of any defective product covered by this Warranty. Avlite Systems will not be liable to Buyer for consequential damages resulting from any defect or deficiencies in accepted items.

Limited to Original Purchaser

This Warranty is for the sole benefit of the original purchaser of the covered product and shall not extend to any subsequent purchaser of the product.

Miscellaneous

Apart from the specific warranties provided under this warranty, all other express or implied warranties relating to the above product is hereby excluded to the fullest extent allowable under law. The warranty does not extend to any lost profits, loss of good will or any indirect, incidental or consequential costs or damages or losses incurred by the purchaser as a result of any defect with the covered product.

Warrantor

Avlite Systems has authorised distribution in many countries of the world. In each country, the authorised importing distributor has accepted the responsibility for warranty of products sold by distributor. Warranty service should normally be obtained from the importing distributor from whom you purchased your product. In the event of service required beyond the capability of the importer, Avlite Systems will fulfil the conditions of the warranty. Such product must be returned at the owner's expense to the Avlite Systems factory, together with a photocopy of the bill of sale for that product, a detailed description of the problem, and any information necessary for return shipment.

Other Avlite Products Available



Solar Aviation Lighting



Radio Controlled & PALC Systems (FCC Compliant)



Obstruction Lighting (LIOL A & LIOL B)



Airfield Markers & Accessories

Typical Applications

- Temporary & permanent airfield lighting
- Remote, emergency & defence airfield lighting
- Barricade, hazard & perimeter lighting
- Obstruction Lighting

For a complete list of product compliances including ICAO & FAA, please contact Avlite today



Area & Sign Lighting



Head Office

Avlite Systems
11 Industrial Drive
Somerville, Vic 3912
Australia

Tel: +61 (0)3 5977 6128
Fax: +61 (0)3 5977 6124

Email: info@avlite.com
Internet: www.avlite.com

A subsidiary of Sealite Pty Ltd www.sealite.com