

**Avlite**<sup>®</sup>  
www.avlite.com



**AV-OL-ILAB-12-R & AV-OL-FL810-12-R**  
**Universal DC Low Intensity Obstruction Light**  
**Installation & Service Manual**

Version 2.5



Version No.	Description	Date	Approved
1.0	Manual launch	Feb 2013	A. Groell
2.0	Various	June 2013	A. Groell
2.1	Spec table update	August 2013	A. Groell
2.2	Alarm relay, RS232 & RS422/485 update	August 2013	A. Groell
2.3	Dip Switch Table	September 2013	A. Groell
2.4	Update: Wind speed	November 2013	S. Turner
2.5	Update: Intensity & Operation Mode Setting	September 2014	W. Evans



## Table of Contents

<b>Introduction</b> .....	Page 4
<b>Technology</b> .....	Page 4
<b>AV-OL-ILAB-12-R &amp; AV-OL-FL810-12-R Models</b> .....	Page 5
<b>Theory of Operation</b> .....	Page 8
<b>Safety Information</b> .....	Page 9
<b>Unpacking, Installation, Wiring &amp; Setup</b> .....	Page 10
Unpacking.....	Page 10
Installation & Wiring .....	Page 10
Setup .....	Page 12
Opening & Closing the Light Head .....	Page 12
Intensity & Operation Mode Setting.....	Page 13
Alarm Relay Output.....	Page 14
Optional RS232 & RS422/485 Communications.....	Page 14
<b>Maintenance &amp; Servicing</b> .....	Page 15
<b>Trouble Shooting</b> .....	Page 16
<b>Appendix</b> .....	Page 17
Wiring diagram.....	Page 17
Parts Diagram.....	Page 18
Product Order Codes.....	Page 19
Certifications & Compliance.....	Page 20
<b>Avlite Light Warranty</b> .....	Page 22



## **Introduction**

**Congratulations! By choosing to purchase an Avlite light, you have become the owner of one of the most advanced LED obstruction lights in the world.**

Avlite Systems draws on more than 25 years experience in the design and manufacture of navigation aids, and particular care has been taken to ensure your light gives years of trouble free service.

As a commitment to producing the highest quality products for our customers, Avlite has been independently certified as complying with the requirements of ISO 9001:2008 quality management system.

By taking a few moments to browse through this booklet, you will become familiar with the versatility of your light, and be able to maximise its operating function.

Please remember to complete the Avlite warranty registration card accompanying your light.

## **Technology**

***Avlite Systems is a world-class solar lighting systems manufacturer with a proven reputation for rapid, innovative, and agile technology solutions designed specifically for defense, government, civil and humanitarian aid operations in the most remote, toughest environments.***

### **Electronics**

Avlite employs leading in-house electronic engineers in the design and development of software and related circuitry. All individual electronic components are sourced directly by Avlite procurement staff ensuring that only the highest quality components are used in our products.

### **LED Technology**

All Avlite lights use the latest advancements in LED (Light Emitting Diode) technology as a light source. The major advantage of LED's over traditional light sources is well established in that they typically have an operational life in excess of 100,000 hours, resulting in substantial savings to maintenance and servicing costs.

### **Precision Construction**

Commitment to investing in the design and construction of injection-moulded parts including optic lenses, light bases and a range of other components ensures that all Avlite products are of a consistent and superior quality.

### **Optical Performance**

Avlite manufactures a range of aviation LED lenses moulded from multi-cavity dies. The company has superior in-house lens manufacturing capabilities to support outstanding optical performance.

### **Award-winning, Patented Technology**

Several United States and Australian patent registrations are held on Avlite's range of innovative designs, with other regional patents pending in Canada, United Kingdom and Europe.

## AV-OL-ILAB-12-R & AV-OL-FL810-12-R Models

*This Avlite light fixture is a steady burning, low intensity LED obstruction light designed to comply with FAA L-810 and ICAO LIOL Type A & B requirements. The model can be used for marking obstacles which pose a threat to aircraft, such as telecommunication towers, wind turbines, buildings and other tall structures.*

*Avlite's LED obstruction lights offer an ultra bright, energy efficient and cost effective lighting solution.*

*The light fixture is available in universal DC (12-48VDC). The advanced light optic uses a single LED for minimal power consumption. The corrosion resistant, polycarbonate lens is specifically designed for use with LEDs to maximize light intensity and uniformity.*

*The light fixture incorporates internal diagnostic checking and an alarm contact for remote monitoring. The alarm relay will be released whenever there is a problem e.g. no power, supply voltage too low, LED failure, etc. The alarm relay will remain energized during the day when operating normally.*

*The ICAO model has adjustable intensity settings to allow the user to easily toggle between 10cd (ICAO Type A) and 32cd (ICAO Type B) light intensities.*



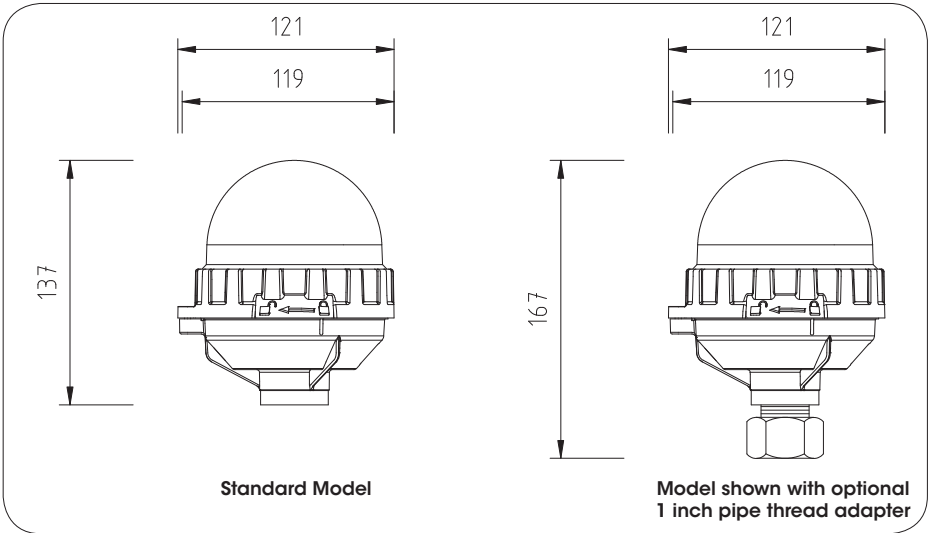
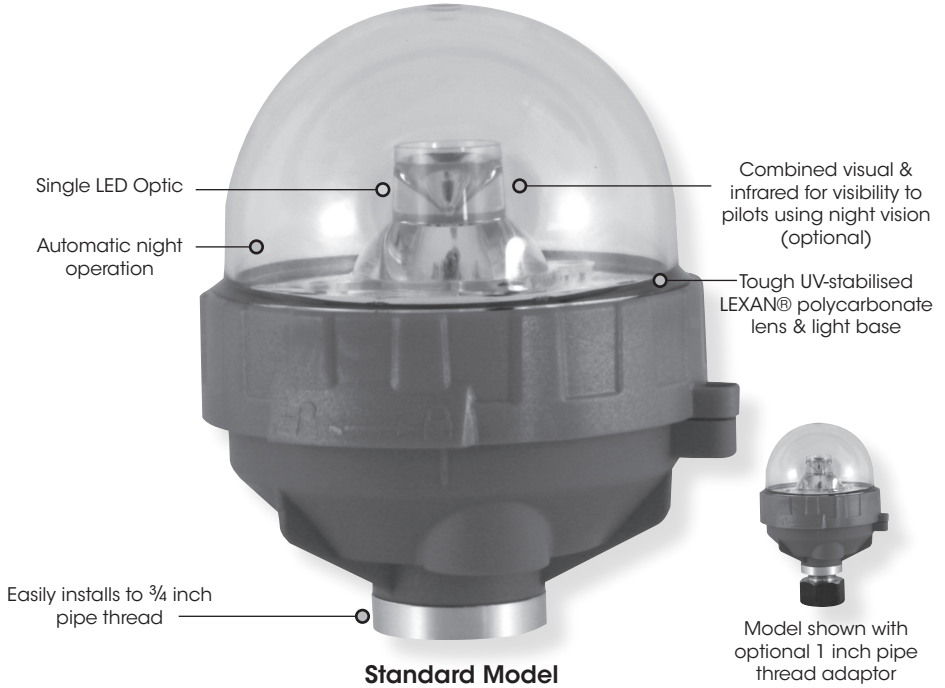

## SPECIFICATIONS • \*

## 12-48 VDC

### Light Characteristics

Light Source

As tested;

ICAO: AV-OL-ILAB-12 (Type A) & AV-OL-ILAB-12 (Type B)

FAA: AV-OL-FL810-12-R LED

Available colors

Red as standard. Other colors available on request, including IR

Peak Intensity (cd)†

Complies with ICAO LIOLA & LIOLB and FAA L-810 obstruction lights

Horizontal Output (degrees)

360

Vertical Divergence (degrees)

ICAO Model: as per ICAO Type A/B specification

FAA Model: as per FAA L-810 obstruction light specification

Reflector Type

Single LED Optic

Intensity Adjustments

ICAO Model: User-adjustable between 10cd & 32cd

FAA Model: 32.5cd

Operation Mode Adjustment

User-adjustable between dusk-till-down & 24 hour operation

LED Life Expectancy (hours)

>100,000

### Electrical Characteristics

Operating Voltage

12 – 48 VDC

Current Draw (mA)

@ 12V:

ICAO LIOL Type A @ 10cd Steady-on with relay energised & IR: I<sub>max</sub> = 65

ICAO LIOL Type B @ 32cd Steady-on with relay energised & IR: I<sub>max</sub> = 135

FAA L-810 @ 32.5cd Steady-on with relay energised & IR: I<sub>max</sub> = 135

ICAO LIOL Type A @ 10cd Steady-on with relay energised & IR: P<sub>max</sub> = 0.9

ICAO LIOL Type B @ 32cd Steady-on with relay energised & IR: P<sub>max</sub> = 1.75

FAA L-810 @ 32.5cd Steady-on with relay energised & IR: P<sub>max</sub> = 1.75

Power (W)

Integrated

Circuit Protection

-40 to 80°C

Temperature Range

### Physical Characteristics

Body Material

LEXAN® Polycarbonate – UV stabilized

Lens Material

LEXAN® Polycarbonate – UV stabilized

Lens Diameter (mm/inches)

100 / 3 7/8

Lens Design

Single LED Optic

Mounting

Standard Model: 3/4 inch pipe thread

Height (mm/inches)

Standard Model: 137 / 5 1/2

Width (mm/inches)

121 / 4 3/4

Mass (kg/lbs)

0.4 / 7/8

Product Life Expectancy

Up to 12 years

### Environmental Factors

Humidity

0 to 100%, MIL-STD-810F

Icing

22kg per square inch

Wind Speed

Up to 240kph

### Certifications

CE

EN61000-6-3:1997. EN61000-6-1:1997

Quality Assurance

ISO9001:2008

ICAO

Low Intensity Obstruction Light Type A & B

FAA

L-810 Steady-burning Red Obstruction Light (Qualified by Intertek)

Waterproof

IP67

### Intellectual Property

Trademarks

AVLITE® is a registered trademark of Avlite Systems

### Warranty \*

3 year warranty

### Options Available

- Variety of solar/battery configurations
- Dual visual/IR output
- IR LED
- RS422/485 communications port
- Threaded adaptor to fit one (1) inch pipe

• Specifications subject to change or variation without notice  
\* Subject to standard terms and conditions  
† Intensity setting subject to solar availability





## Theory of Operation

When powered up, the light will constantly check day/night status using its internal ambient light sensor. The ambient light sensor averages its measurement for 30 seconds.

**FAA:** By default the lights turn ON when the ambient light decreases to not less than 35 foot-candles (367.7 lux) and turn OFF when the ambient light decreases to not more than 60 foot-candles (645.8 lux). These limits can be factory adjusted, if required.

**ICAO:** By default the lights turn ON when the ambient light decreases to not less than 35 foot-candles (100 lux) and turn OFF when the ambient light decreases to not more than 60 foot-candles (150 lux). These limits can be factory adjusted, if required.

If the light detects a LED failure the alarm relay can be used to provide a feedback to the user.





# Safety Information

## Safety Information

- Install the light in compliance with the effective local electrical code(s).
- Mains power should always be disconnected when work is being done in close proximity to electrical fittings, and electrical work should only be done by a licensed electrician.
- Operate the light only within the indicated electrical ratings and product usage instructions.
- To ensure that the light and peripheral equipment function safely and correctly, use cable in compliance with the effective local electrical code.
- Do not stare at the LED or shine the LED into your eyes or those of another person.
- Do dispose of the product according to the local laws and regulations for your region, for example, at a recycling center that accepts electronic devices.



# Unpacking, Installation, Wiring & Setup

## Unpacking

Unpack all hardware and inspect for damage. If there is any damage, please contact your Avlite Office. Retain original packing material for possible future use in shipping.

## Installation & Wiring

Before proceeding with installation or service, make sure the following conditions are met:

- Ensure the tower or mast is grounded (NO RF HAZARD)
- Check the mast lighting circuit is not faulty
- Ensure power lines are not 'live' (NO ELECTRICAL HAZARD)
- Avoid touching live circuits!
- Avoid touching any component or any part of the circuitry while the unit is operating. Do not change components or make adjustments inside the unit with power on.

Open the Obstruction Light as described. Guide the cable through the cable gland and mount the bottom half of the Obstruction Light on a mounting pole using the inner thread.

### **NOTE:**

- Make sure the mounting pole is vertically aligned to guarantee the required beam pattern of the obstruction light
- Make sure the light's beam pattern is not disturbed by any nearby obstacles

Shorten the cable and close/seal the cable gland.

With the unit open, observe the rear of the PCB mounted in the top half of the Obstruction Light for terminal blocks and switch settings.

**NOTE:** Use cable in compliance with the effective local electrical code. The cable outer diameter should be between 5mm and 10mm.

**NOTE:** There is no requirement to terminate the relay and/or the serial communication if not used.

### **DC POWER CONNECTION**

The unit is designed to operate from a nominal DC voltage from 12V to 48V.

Wire as follows:

- Positive supply (+) = +VDC
- Negative supply (-) = 0V

For location details of the terminals please refer to Figure 1.

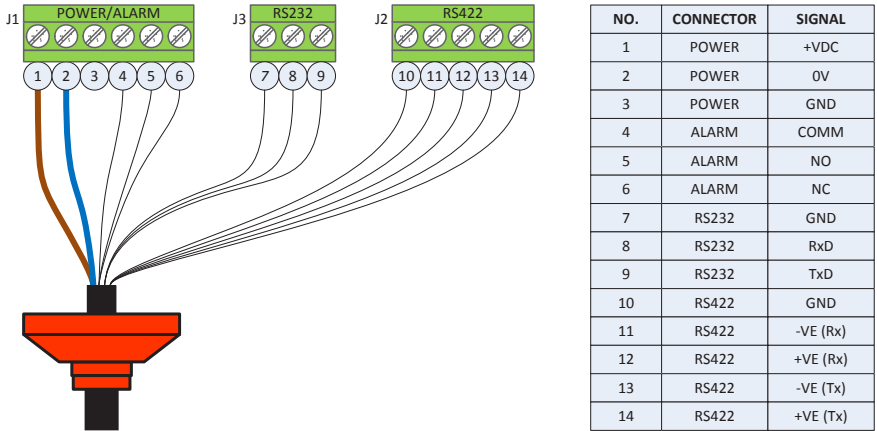

Figure 1. Light wiring diagram and pinning

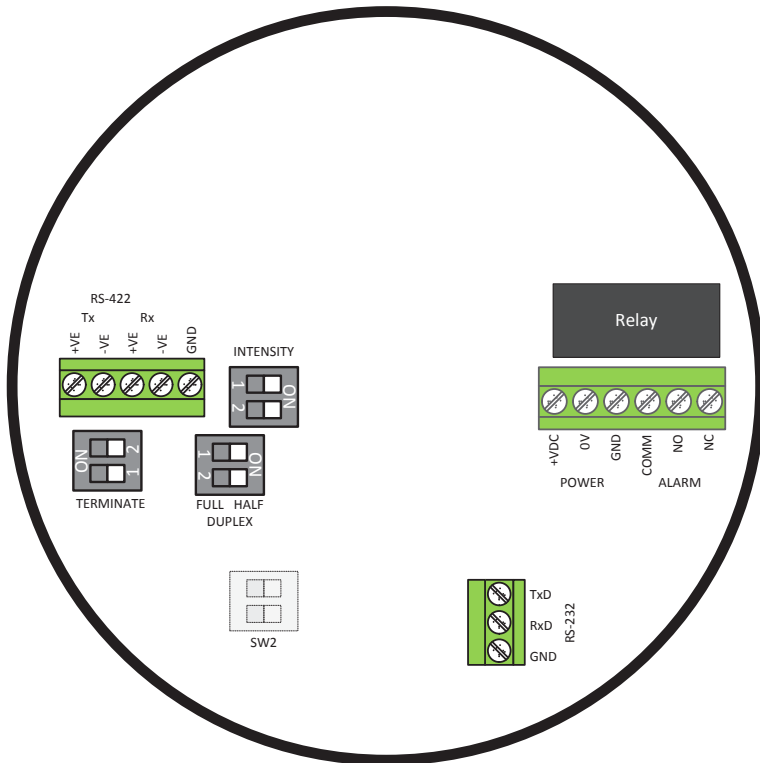

Figure 2. DC Obstruction Light PCB with terminals and DIP switches

## Setup

### OPENING & CLOSING THE LIGHT HEAD

- Remove the locking screw
- In order to open the unit, the top half of the unit should be turned anti-clockwise with respect to the bottom half. The top half will turn approximately 20mm over a positive "click" before separating from the bottom half. Attention should be paid to the restriction caused by the internal cabling which is secured by a cable gland.
- The unit is closed by reversing the above procedure, ensuring the black rubber O-ring remains in place.



**Figure 3. Obstruction Light**

**INTENSITY & OPERATION MODE SETTING**

**Light intensity & operation mode setting for ICAO compliant light fixture**

The fixture will be supplied with the ICAO compliant optic.

The obstruction light will be pre-set to the intensity setting specified by the customer (ICAO Type A or ICAO Type B) for a red steady burning Low Intensity Obstruction Light in dusk-till-dawn mode. The intensity and operation mode is pre-set in the factory and does not need to be set by the user.

If the customer should need to change the intensity or operation mode settings of the ICAO compliant model they can do this by changing the INTENSITY DIP switch. Please refer to table below for DIP switch settings and Figure 2 for circuit board location.

Position 2	Position 1	Light Intensity
OFF	OFF	ICAO Low Intensity Obstruction Light Type A (10cd), dusk-till-dawn mode – DEFAULT
OFF	ON	ICAO Low Intensity Obstruction Light Type A (10cd), 24 hour mode
ON	OFF	ICAO Low Intensity Obstruction Light Type B (32cd), dusk-till-dawn mode
ON	ON	ICAO Low Intensity Obstruction Light Type B (32cd), 24 hour mode

**Light intensity & operation mode setting for FAA compliant light fixture**

The fixture will be supplied with the FAA compliant optic.

The FAA compliant model comes pre-set to the correct intensity for L-810 steady burning red obstruction light in dusk-till-dawn mode. The intensity and operation mode is pre-set in the factory and does not need to be set by the user.

If the customer should need to change the operation mode settings of the FAA compliant model they can do this by changing the INTENSITY DIP switch. Please refer to table below for DIP switch settings and Figure 2 for circuit board location.

Position 2	Position 1	Light Intensity
No function	OFF	FAA L-810 Low Intensity Obstruction Light, dusk-till-dawn mode – DEFAULT
No function	ON	FAA L-810 Low Intensity Obstruction Light, 24 hour mode

**NOTE:**

The ICAO Model and FAA Model have their own unique optic. The ICAO model cannot be used for FAA purposes and the FAA model cannot be used for ICAO purposes. The model required needs to be specified at the time of order.

**NOTE:**

The unit must be installed by a qualified electrician.

## ALARM RELAY OUTPUT

In normal operation the relay is energised

- Terminal contacts COMM and NC of the relay are electrically closed
- Terminal contacts COMM and NO of the relay are electrically open

Whenever the LED is not lit due to a power failure and/or a LED failure the relay will not be energised.

- Terminal contacts COMM and NO of the relay are electrically closed
- Terminal contacts COMM and NC of the relay are electrically open

For location details of the terminals please refer to Figure 2.

The alarm relay comes configured as follows:

- Relay normal operation (default, as described above)

The following alarm relay configurations are available as a special order. These must be specified at the time of order:

- Relay inverse operation (inverse functionality of the normal operation, used to conserve power)
- Relay disable (in case the relay is not required, used to conserve power)

**NOTE: The alarm relay is intended for low voltage (SELV) connection only.  
NOT FOR MAINS CONNECTION**

## RS232 AND RS422/485 COMMUNICATION (OPTIONAL)

The Obstruction Light offers a RS232 and a R2422/485 interface.

**RS232** Typical 3 pin TxD, RxD and GND arrangement

**RS422/485** Typical 4 pin arrangement with Termination selection and Duplex/Halfduplex selection

For location details please refer to Figure 2.

Duplex		
SW3		
S1	S2	
OFF	OFF	Simplex operation
ON	ON	Duplex operation

Termination		
SW4		
S1	S2	
OFF	OFF	No termination
ON	ON	120 Ohm termination

Please contact AVLITE for further details.



## **Maintenance & Servicing**

Designed to be maintenance free the Obstruction Lights requires minimal attention, though the following maintenance and servicing information is provided to help ensure the life of your Avlite product.

- Occasional cleaning of the dome lens may be required using a cloth and warm soapy water.



## Trouble Shooting

Problem	Remedy
Light will not activate.	<ul style="list-style-type: none"><li>• Ensure proper connectivity with power supply</li><li>• Ensure that the power supply has the right polarity and voltage range</li><li>• Cover the light sensor to force the light ON</li></ul>



# Appendix

## Wiring Diagram

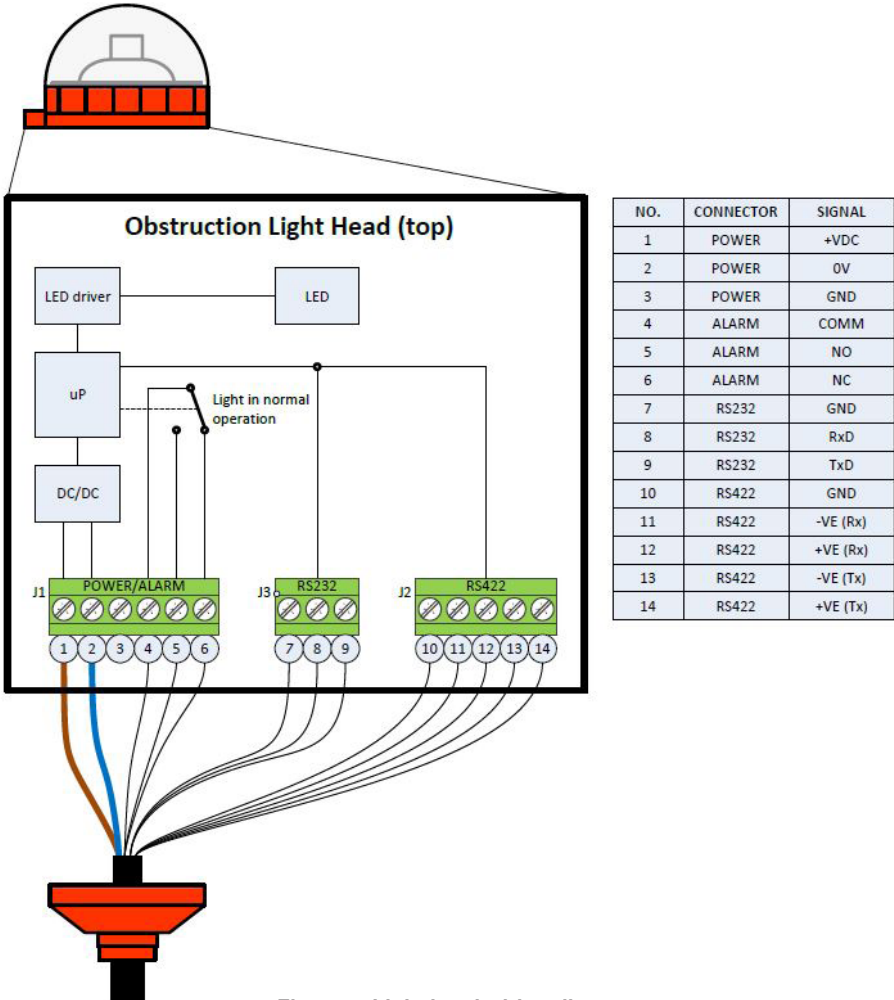
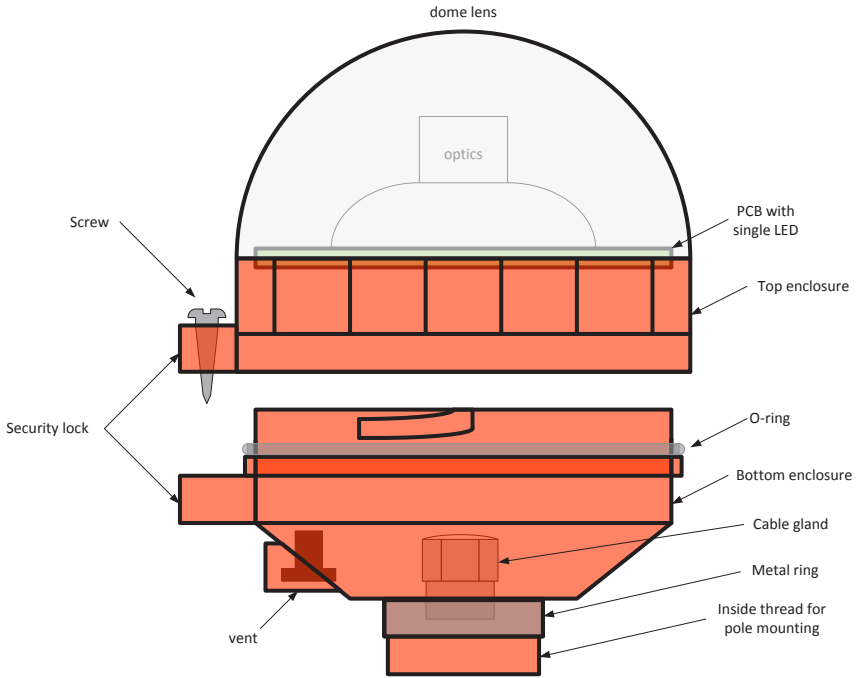

Figure 4. Light head wiring diagram

**Parts Diagram**



**Figure 5. Light head parts diagram**

**Product Order Codes**

**HOW TO ORDER AV-OL Series Obstruction Lights:**

**ICAO Compliant**

**FAA Compliant**

AV-OL-ILAB-[Model]-[Color]-[?]-[?]-[?]-[?]-[?]

AV-OL-FL810-[Model]-[Color]-[?]-[?]-[?]-[?]-[?]

**Product No.:** \_\_\_\_\_

**Product No.:** \_\_\_\_\_

**Model:** \_\_\_\_\_

**Model:** \_\_\_\_\_

12 = 12-48 VDC  
UM = 110-240 VAC

12 = 12-48 VDC  
UM = 110-240 VAC

**Color:** \_\_\_\_\_

**Color:** \_\_\_\_\_

R = Red  
IR = Infrared  
RIR = Combined Red/IR

R = Red  
IR = Infrared  
RIR = Combined Red/IR

**Single or Dual Fixture:** \_\_\_\_\_

**Single or Dual Fixture:** \_\_\_\_\_

[blank] = Single light fixture  
[D] = Dual light fixture

[blank] = Single light fixture  
[D] = Dual light fixture

**Solar/Battery Configuration:** \_\_\_\_\_

**Solar/Battery Configuration:** \_\_\_\_\_

CT1 = Type 1  
CT2 = Type 2  
[blank] = No solar/battery configuration

CT1 = Type 1  
CT2 = Type 2  
[blank] = No solar/battery configuration

**Monitoring & Control:** \_\_\_\_\_

**Monitoring & Control:** \_\_\_\_\_

G = GSM  
RF = Radio Control  
[blank] = No monitoring & control

G = GSM  
RF = Radio Control  
[blank] = No monitoring & control

**RS Communications Port (12-48VDC Model only):** \_\_\_\_\_

**RS Communications Port (12-48VDC Model only):** \_\_\_\_\_

RS = RS communications port  
[blank] = No RS communications port

RS = RS communications port  
[blank] = No RS communications port

**Feature:** \_\_\_\_\_

**Feature:** \_\_\_\_\_

0 = Both lights activated at the same time  
1 = One light activated with automatic changeover ability  
[blank] = No feature

0 = Both lights activated at the same time  
1 = One light activated with automatic changeover ability  
[blank] = No feature



## **Certifications & Compliance**

Certified to: FAA AC NO: 150/5345-43G L-810 (L)  
FAA Engineering Brief No. 67

Compliant to: ICAO Annex 14 Volume 1, 'Aerodrome Design and Operations', Fourth Edition July 2004,  
Table 6.3, Low Intensity Type A & B Obstruction Light



**Notes**



## **Avlite Light Warranty V1.1**

### **Activating the Warranty**

Upon purchase, the Avlite Systems warranty must be activated for recognition of future claims. To do this you have two (2) options:

**1. Postal Registration**

Please complete the Avlite Systems Warranty Registration Card and return to Avlite within 30 days of your purchase.

**2. Online Registration**

Please complete the Online Registration Form at; [www.avlite.com](http://www.avlite.com)

***Avlite Systems will repair or replace your lantern in the event of electronic failure for a period of up to three years from the date of purchase.***

***The unit must be returned to Avlite freight prepaid.***

### **Warranty Terms**

1. Avlite Systems warrants that any Avlite aviation products fitted with telemetry equipment including but not limited to AIS, GSM, GPS or RF ("Telemetry Products") will be free from defective materials and workmanship under normal and intended use, subject to the conditions hereinafter set forth, for a period of twelve (12) months from the date of purchase by the original purchaser.
2. Avlite Systems warrants that any rotationally-moulded products ("Roto-Moulded Products") and accessory products ("Accessory Products") will be free from defective materials and workmanship under normal and intended use, subject to the conditions hereinafter set forth, for a period of twelve (12) months from the date of purchase by the original purchaser.
3. Avlite Systems warrants that any Avlite aviation products other than the Telemetry Products, Roto-Moulded Products and Accessory Products ("Avlite Products") will be free from defective materials and workmanship under normal and intended use, subject to the conditions hereinafter set forth, for a period of three (3) years from the date of purchase by the original purchaser.
4. Avlite Systems will repair or replace, at Avlite's sole discretion, any Telemetry Products, Roto-Moulded Products, Accessory Products or Avlite Products found to be defective in material and workmanship in the relevant warranty period so long as the Warranty Conditions (set out below) are satisfied.
5. If any Telemetry Products or Avlite Products are fitted with a rechargeable battery, Avlite Systems warrants the battery will be free from defect for a period of one (1) year when used within original manufacturer's specifications and instructions.

### **Warranty Conditions**

This Warranty is subject to the following conditions and limitations;

1. The warranty is applicable to lanterns manufactured from 1/1/2009.
2. The warranty is void and inapplicable if:
  - a. the product has been used or handled other than in accordance with the instructions in the owner's manual and any other information or instructions provided to the customer by Avlite;
  - b. the product has been deliberately abused, or misused, damaged by accident or neglect or in being transported; or
  - c. the defect is due to the product being repaired or tampered with by anyone other than Avlite or authorised Avlite repair personnel.
3. The customer must give Avlite Systems notice of any defect with the product within 30 days of the customer becoming aware of the defect.
4. Rechargeable batteries have a limited number of charge cycles and may eventually need to be replaced. Typical battery replacement period is 3-4 years. Long term exposure to high temperatures will shorten the battery life. Batteries used or stored in a manner inconsistent with the manufacturer's specifications and instructions shall not be covered by this warranty.



5. No modifications to the original specifications determined by Avlite shall be made without written approval of Avlite Systems.
6. Avlite lights can be fitted with 3rd party power supplies and accessories but are covered by the 3rd party warranty terms and conditions.
7. The product must be packed and returned to Avlite Systems by the customer at his or her sole expense. Avlite Systems will pay return freight of its choice. A returned product must be accompanied by a written description of the defect and a photocopy of the original purchase receipt. This receipt must clearly list model and serial number, the date of purchase, the name and address of the purchaser and authorised dealer and the price paid by the purchaser. On receipt of the product, Avlite Systems will assess the product and advise the customer as to whether the claimed defect is covered by this warranty.
8. Avlite Systems reserves the right to modify the design of any product without obligation to purchasers of previously manufactured products and to change the prices or specifications of any product without notice or obligation to any person.
9. Input voltage shall not exceed those recommended for the product.
10. Warranty does not cover damage caused by the incorrect replacement of battery in solar lantern models.
11. This warranty does not cover any damage or defect caused to any product as a result of water flooding or any other acts of nature.
12. There are no representations or warranties of any kind by Avlite or any other person who is an agent, employee, or other representative or affiliate of Avlite, express or implied, with respect to condition of performance of any product, their merchantability, or fitness for a particular purpose, or with respect to any other matter relating to any products.

### **Limitation of Liability**

To the extent permitted by section 68A of the Trade Practices Act 1974 (Cth), the liability of Avlite Systems under this Warranty will be, at the option of Avlite Systems, limited to either the replacement or repair of any defective product covered by this Warranty. Avlite Systems will not be liable to Buyer for consequential damages resulting from any defect or deficiencies in accepted items.

### **Limited to Original Purchaser**

This Warranty is for the sole benefit of the original purchaser of the covered product and shall not extend to any subsequent purchaser of the product.

### **Miscellaneous**

Apart from the specific warranties provided under this warranty, all other express or implied warranties relating to the above product is hereby excluded to the fullest extent allowable under law. The warranty does not extend to any lost profits, loss of good will or any indirect, incidental or consequential costs or damages or losses incurred by the purchaser as a result of any defect with the covered product.

### **Warrantor**

Avlite Systems has authorised distribution in many countries of the world. In each country, the authorised importing distributor has accepted the responsibility for warranty of products sold by distributor. Warranty service should normally be obtained from the importing distributor from whom you purchased your product. In the event of service required beyond the capability of the importer, Avlite Systems will fulfil the conditions of the warranty. Such product must be returned at the owner's expense to the Avlite Systems factory, together with a photocopy of the bill of sale for that product, a detailed description of the problem, and any information necessary for return shipment.

**Other Avlite Products Available**



**Solar Aviation Lighting**



**Helipad Lighting**



**Obstruction Lighting**



**Airfield Markers  
& Accessories**

**Typical Applications**

- Temporary & permanent airfield lighting
- Remote, emergency & defence airfield lighting
- Barricade, hazard & perimeter lighting
  - Helipad lighting
- Obstruction lighting

For a complete list of product compliances including ICAO & FAA, please contact Avlite today



**Area & Sign Lighting**



**Head Office**

Avlite Systems  
11 Industrial Drive  
Somerville, Vic 3912  
Australia

Tel: +61 (0)3 5977 6128  
Fax: +61 (0)3 5977 6124

Email: info@avlite.com  
Internet: www.avlite.com

A subsidiary of Sealite Pty Ltd www.sealite.com