

Avlite[®]
www.avlite.com



AV-OL-FL864-12-R & AV-OL-FL864-UM-R
FAA L-864 Medium Intensity
Obstruction Light
Universal DC & Universal AC Models
Installation & Service Manual

Version 1.4



Version No.	Description	Date	Approved
1.0	Manual launch	March 2015	W. Evans
1.1	Spec table update	March 2015	J. Dore
1.2	Warranty update	March 2015	W. Evans
1.3	Update installation & wiring	June 2015	W. Evans
1.4	Spec table update	Dec 2016	W. Evans

Table of Contents

Introduction	Page 4
Technology	Page 4
AV-OL-FL864-12-R & AV-OL-FL864-UM-R Models	Page 5
Safety Information	Page 8
Unpacking, installation, wiring & setup	Page 9
Unpacking.....	Page 9
Installation & Wiring.....	Page 9
Operation & Setup	Page 12
Intensity Setting.....	Page 12
Alarm Relay Output.....	Page 12
Momentary Button operation	Page 12
RS232 and RS422/485 Communication (optional)	Page 13
Optional IR Remote Control	Page 14
Avlite IR Controller / Universal Remote Compatibility	Page 14
IR Controller Functions.....	Page 15
Test Mode / Configure	Page 15
Normal Operation	Page 15
Read	Page 15
Operational Mode.....	Page 16
Battery Status.....	Page 16
Error/Acknowledge Indication.....	Page 16
Optional GPS Synchronisation	Page 17
Optional GSM Monitoring & Control	Page 18
Maintenance & Servicing	Page 19
Trouble Shooting	Page 19
Lantern Status	Page 20
Certifications & Compliance	Page 21
Avlite Light Warranty	Page 22

Introduction

Congratulations! By choosing to purchase an Avlite light, you have become the owner of one of the most advanced LED obstruction lights in the world.

Avlite Systems draws on more than 25 years experience in the design and manufacture of navigation aids, and particular care has been taken to ensure your light gives years of trouble free service.

As a commitment to producing the highest quality products for our customers, Avlite has been independently certified as complying with the requirements of ISO 9001:2008 quality management system.

By taking a few moments to browse through this booklet, you will become familiar with the versatility of your light, and be able to maximise its operating function.

Please remember to complete the Avlite warranty registration card accompanying your light.

Technology

Avlite Systems is a world-class solar lighting systems manufacturer with a proven reputation for rapid, innovative, and agile technology solutions designed specifically for defense, government, civil and humanitarian aid operations in the most remote, toughest environments.

Electronics

Avlite employs leading in-house electronic engineers in the design and development of software and related circuitry. All individual electronic components are sourced directly by Avlite procurement staff ensuring that only the highest quality components are used in our products.

LED Technology

All Avlite lights use the latest advancements in LED (Light Emitting Diode) technology as a light source. The major advantage of LED's over traditional light sources is well established in that they typically have an operational life in excess of 100,000 hours, resulting in substantial savings to maintenance and servicing costs.

Precision Construction

Commitment to investing in the design and construction of injection-moulded parts including optic lenses, light bases and a range of other components ensures that all Avlite products are of a consistent and superior quality.

Optical Performance

Avlite manufactures a range of aviation LED lenses moulded from multi-cavity dies. The company has superior in-house lens manufacturing capabilities to support outstanding optical performance.

Award-winning, Patented Technology

Several United States and Australian patent registrations are held on Avlite's range of innovative designs, with other regional patents pending in Canada, United Kingdom and Europe.

AV-OL-FL864-12-R & AV-OL-FL864-UM-R Medium Intensity Obstruction Light

This Avlite medium intensity LED obstruction light is certified to the FAA L-864 Medium Intensity Obstruction Lighting advisory circular 150/5345-43. The light is used to mark obstacles such as telecommunication and utility towers, wind turbines, cranes, buildings and other tall structures.

Avlite's LED obstruction lights offer an ultra bright, energy efficient and cost effective lighting solution. The light fixture is available in two configurations, universal DC (12–48VDC) or universal AC (110–240VAC).

The light fixture incorporates internal diagnostic checking and an alarm contact for remote monitoring. The alarm relay is energised in normal operation and is released if there is an LED or power fault.



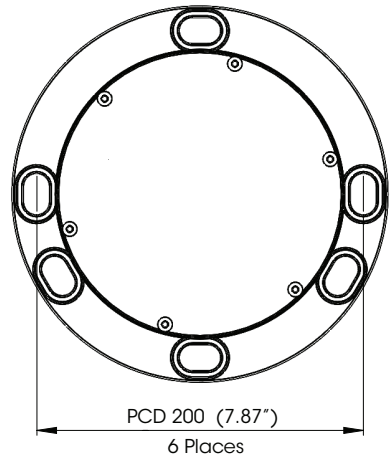
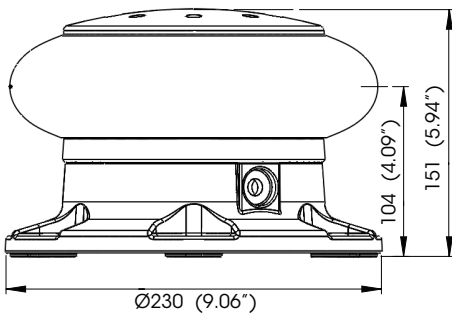

SPECIFICATIONS * *	FAA L-864 MIOL	
	12-48 VDC	110-240 VAC
Light Characteristics		
Available colors	Red as standard. Other colors available on request	Red as standard. Other colors available on request
Effective Intensity (cd) †	2000cd ± 25%	2000cd ± 25%
Horizontal Output (degrees)	360	360
Vertical Divergence (degrees)	3°	3°
Available Flash Characteristics	0.5s ON, 2.5s OFF - 16.6% duty cycle	0.5s ON, 2.5s OFF - 16.6% duty cycle
Electrical Characteristics		
Operating Voltage	12 - 48 VDC	110 - 240 VAC 50/60Hz
Power (Average Flashing)	6W	Pmax: 6W, Smax: 8VA
Power (Peak)	36W	Pmax: 36W, Smax 48VA
Circuit Protection	Integrated	Integrated
Temperature Range	-40 to 80°C	-40 to 80°C
Physical Characteristics		
Body Material	7-stage powder-coated aluminium	7-stage powder-coated aluminium
Lens Material	Impact modified UV stabilized acrylic	Impact modified UV stabilized acrylic
Lens Diameter (mm/inches)	171 / 6¾	171 / 6¾
Lens Design	Multi LED Optic	Multi LED Optic
Mounting	200mm bolt pattern	200mm bolt pattern
Height (mm/inches)	151 / 6	151 / 6
Width (mm/inches)	230 / 9	230 / 9
Depth (mm/inches)	230 / 9	230 / 9
Mass (kg/lbs)	5.5 / 12¼	5.8 / 12¾
Product Life Expectancy	12 years plus	12 years plus
Environmental Factors		
Humidity	0 to 100%, MIL-STD-810F	0 to 100%, MIL-STD-810F
Icing	3.41kg per square cm / 48.5lbs per square inch	3.41kg per square cm / 48.5lbs per square inch
Wind Speed	Up to 240kph / 150mph	Up to 240kph / 150mph
Certifications		
CE	EN61000-6-3:2007 EN61000-6-1:2007	EN61000-6-3:2007 EN61000-6-1:2007
Quality Assurance	ISO9001:2008	ISO9001:2008
FAA, DGAC.	L-864 Medium Intensity Obstruction Light (Qualified by Intertek)	L-864 Medium Intensity Obstruction Light (Qualified by Intertek)
Waterproof	IP68	IP68
Intellectual Property		
Trademarks	AVLITE® is a registered trademark of Avlite Systems	AVLITE® is a registered trademark of Avlite Systems
Warranty *	5 year warranty	5 year warranty
Options Available	<ul style="list-style-type: none"> • Variety of solar/battery configurations • GSM Cell-Phone Monitoring • GPS Synchronisation • RS422/485 communications port 	<ul style="list-style-type: none"> • GSM Cell-Phone Monitoring • GPS Synchronisation • RS422/485 communications port



• Specifications subject to change or variation without notice
* Subject to standard terms and conditions
† Intensity setting subject to solar irradiability



Safety Information

- Install the light in compliance with the effective local electrical code(s).
- Mains power should always be disconnected when work is being done in close proximity to electrical fittings, and electrical work should only be done by a licensed electrician.
- Operate the light only within the indicated electrical ratings and product usage instructions.
- To ensure that the light and peripheral equipment function safely and correctly, use cable in compliance with the effective local electrical code.
- Do not stare at the LED or shine the LED into your eyes or those of another person.
- Do dispose of the product according to the local laws and regulations for your region, for example, at a recycling center that accepts electronic devices.



Unpacking, Installation, Wiring & Setup

Unpacking

Unpack all hardware and inspect for damage. If there is any damage, please contact your Avlite Office. Retain original packing material for possible future use in shipping.

Installation & wiring

Before proceeding with installation or service, make sure the following conditions are met:

- Ensure the tower or mast is grounded (NO RF HAZARD)
- Check the mast lighting circuit is not faulty
- Ensure power lines are not 'live' (NO ELECTRICAL HAZARD)
- Avoid touching live circuits!
- Avoid touching any component or any part of the circuitry while the unit is operating. Do not change components or make adjustments inside the unit with power on.
- In AC installations, where upstream circuit breakers are utilized, use a 30A Type C breaker.

NOTE:

The obstruction light is manufactured with an input power cable of length defined at the time of order. One end of the input power cable is pre-terminated at the light fixture.

Connect the provided input power cable to the corresponding power source in accordance with figure 1 for AC installations and figure 2 for DC installations.

AC WIRING CONFIGURATION

External:

	Australia/ Europe/ UK	USA/ Canada
Active/Live (L1)	Brown	Black
Neutral (L2)	Blue	White
Earth	Green/Yellow	Green

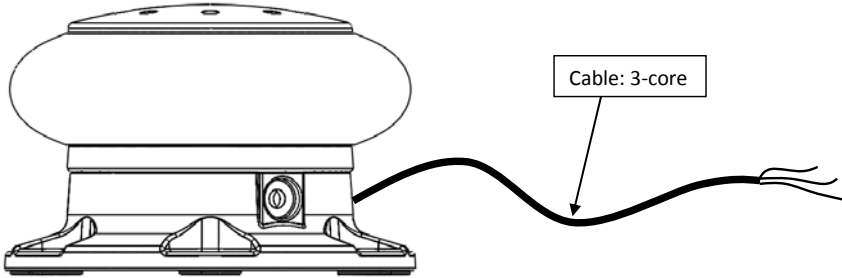

Internal:

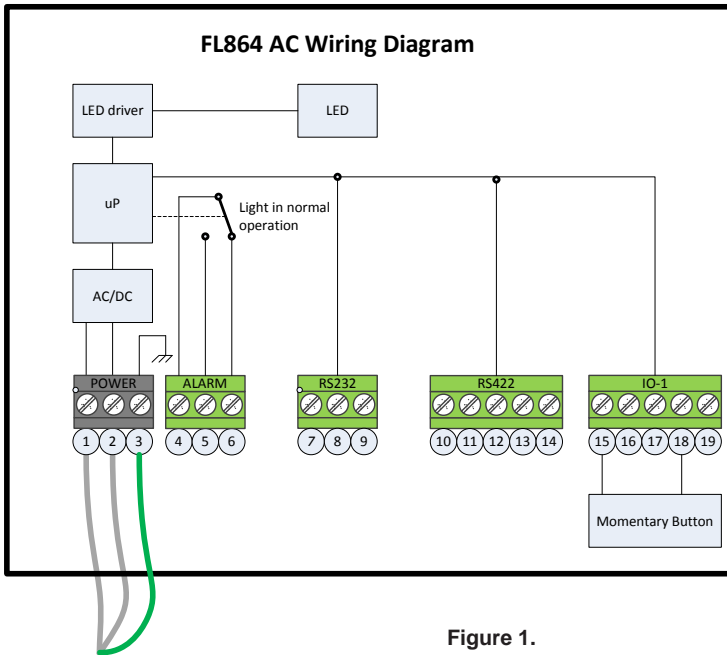

NO.	CONNECTOR	SIGNAL
1	POWER	L1
2	POWER	L2
3	POWER	GND
4	ALARM	COMM
5	ALARM	NO
6	ALARM	NC
7	RS232	GND
8	RS232	RxD
9	RS232	TxD
10	RS422	GND
11	RS422	-VE (Rx)
12	RS422	+VE (Rx)
13	RS422	-VE (Tx)
14	RS422	+VE (Tx)
15	IO-1	3V3
16	IO-1	OUT-1
17	IO-1	0V
18	IO-1	IN-1
19	IO-1	0V

Figure 1.

DC WIRING CONFIGURATION

External:

Positive (+VDC)	Brown
Negative (-VDC)	Blue

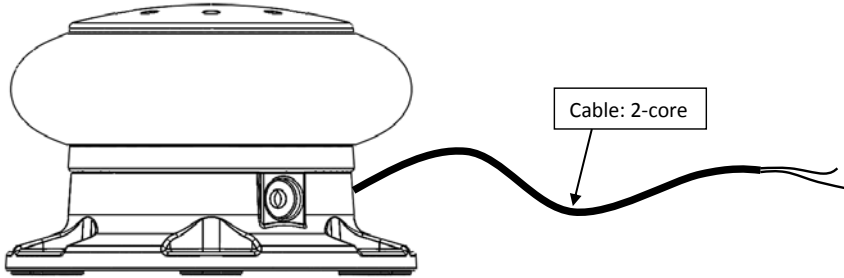

Internal:

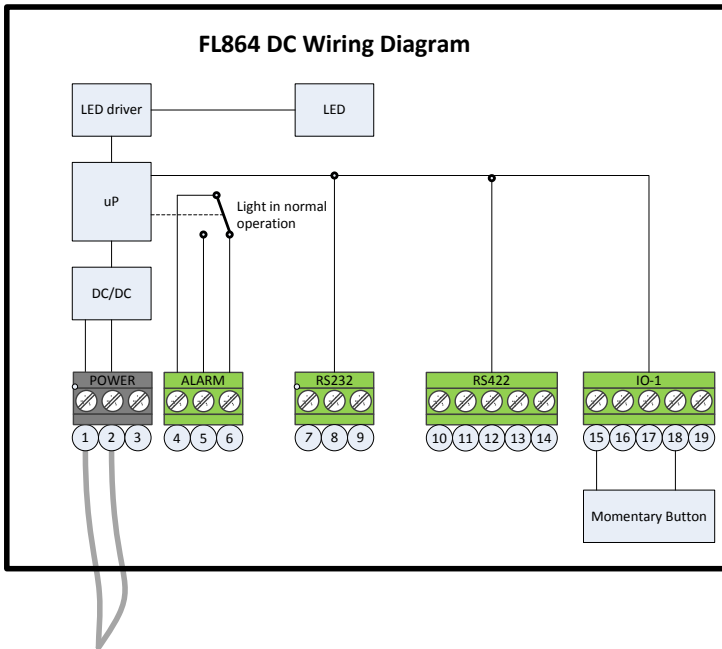

NO.	CONNECTOR	SIGNAL
1	POWER	+VBatt(+VDC)
2	POWER	-VBatt(-VDC)
3	POWER	UNUSED
4	ALARM	COMM
5	ALARM	NO
6	ALARM	NC
7	RS232	GND
8	RS232	RxD
9	RS232	TxD
10	RS422	GND
11	RS422	-VE (Rx)
12	RS422	+VE (Rx)
13	RS422	-VE (Tx)
14	RS422	+VE (Tx)
15	IO-1	3V3
16	IO-1	OUT-1
17	IO-1	0V
18	IO-1	IN-1
19	IO-1	0V

Figure 2.



Operation & Setup

When powered up, the light will constantly check day/night status using its internal ambient light sensor. The ambient light sensor averages its measurement for 30 seconds.

FAA: By default the lights turn ON when the ambient light decreases to not less than 35 foot-candles (367.7 lux) and turn OFF when the ambient light increases to not more than 60 foot-candles (645.8 lux). These limits can be factory adjusted, if required.

INTENSITY SETTING

The fixture will be supplied with a FAA compliant optic.

The obstruction light will be pre-set to the intensity setting required to produce a FAA compliant photometric profile. The intensity is pre-set in the factory and does not need to be set by the user.

ALARM RELAY OUTPUT

In normal operation the relay is energised

- Terminal contacts COMM and NC of the relay are electrically closed
- Terminal contacts COMM and NO of the relay are electrically open

Whenever the LED is not lit due to a power failure and/or a LED failure the relay will not be energised.

- Terminal contacts COMM and NO of the relay are electrically closed
- Terminal contacts COMM and NC of the relay are electrically open

The alarm relay comes configured as follows:

- Relay normal operation (default, as described above)

The following alarm relay configurations are available as a special order. These must be specified at the time of order:

- Relay inverse operation (inverse functionality of the normal operation, used to conserve power)
- Relay disable (in case the relay is not required, used to conserve power)

**NOTE: The alarm relay is intended for low voltage (SELV) connection only.
NOT FOR MAINS CONNECTION**

MOMENTARY BUTTON OPERATION

The AV-OL-FL864 light is fitted with an external momentary button for manual light operation.

The momentary button is incorporated for maintenance, testing and emergency use, this button allows the user to cycle between 'forced on' and 'forced off' mode irrespective of the current ambient light conditions. A momentary button mode change remains active for 4 minutes and then the light reverts to the factory default operation of 'dust-till-dawn'.

To use the momentary button:

1. Hold down the push button for 3 seconds (the light will be forced on again).
2. Press the momentary button again and the light will be forced off.
3. Additional button presses will cycle between these two modes.

RS232 AND RS422/485 COMMUNICATION (OPTIONAL)

The Obstruction Light offers a RS232 and a R2422/485 interface.

RS232 Typical 3 pin TxD, RxD and GND arrangement

RS422/485 Typical 4 pin arrangement with Termination selection and Duplex/Simplex selection

For location details please refer to Figure 1 & 2.

Duplex		
SW3		
S1	S2	
OFF	OFF	Simplex operation
ON	ON	Duplex operation

Termination		
SW4		
S1	S2	
OFF	OFF	No termination
ON	ON	120 Ohm termination

Please contact Avlite for further details.

Optional IR Remote Control

The IR remote is used to communicate with Avlite lighting products that have an IR sensor fitted. The remote control is used for the following functions:

- Operational Mode: dusk-to-dawn, standby or always-on.
- Ambient Light Thresholds: read the current light thresholds, configure new ambient light thresholds.
- Perform a battery health check.

On receiving a valid key signal from the IR Remote, the light will flash once. The user should wait until the light responds to each keypress before pressing another key. If there is no response to the keypress after 3 seconds, it has not been detected by the light and the key can be pressed again.

If an invalid key is detected, the light will flash quickly 5 times. In this case, the command will have to be restarted.

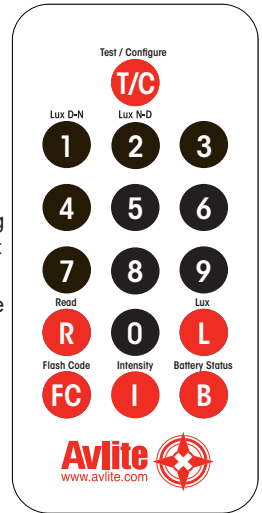

Avlite IR Controller / Universal Remote Compatibility

If you lose your Avlite IR Controller, the following Universal Remote Controller has been tested for compatibility: RCA Type RCR312WR programmed for Phillips TV Type Code 10054

Avlite Key	Universal Remote Key
T	Power
1	1
2	2
3	3
4	4
5	5
6	6
7	7
8	8
9	9
0	0
R	Channel+
L	Mute
FC	Volume+
I	Volume-
B	Channel-

IR Controller Functions

Test Mode / Configure



Pressing the T/C button for up to 5 seconds places the light in Test Mode. The light will flash once in response to the T/C button being pressed and then turn off.

Normal Operation

The light will return to normal operation once it has not detected a valid key press for 30 seconds. The light will flash once to indicate it is returning to normal operation.

Read

Pressing the Read followed by one of the configuration keys shall cause the light to flash the configured value.

Example Key Sequences:



The light flashes the current battery status.



The light flashes the sunset level in Lux, followed by a 2 second gap, followed by the sunrise level. Levels are in the range of 1 to 9.



The light flashes the Operational Mode. Modes are as follows:
1 flash = Always-On
2 flashes = Standby
3 flashes = Dusk-to-Dawn



Operational Mode

The light has three modes of operation: *Always on*, *Standby Mode* and *Dusk-to-Dawn* mode. These modes can be selected either via the IR remote control or via the GSM module (if fitted).

In Always On mode, the daylight sensor is disabled and the lantern will remain ON.

In Standby mode, the lantern is turned off and the daylight sensor is disabled. This mode does not affect the operation of the GSM module.

In Dusk-to-Dawn, the daylight sensor is enabled.

B **1** **T/C** Always on mode

B **2** **T/C** Standby mode

B **3** **T/C** Dusk-to-Dawn mode

Battery Status (12V system only)

B

This function reads the battery status. The response from the light is:

4 flashes = High Voltage

3 flashes = Good Voltage

2 flashes = Low Voltage

1 flashes = Cutoff Voltage or below

Example Key sequence:

R **B** **T/C**

Error/Acknowledge Indication

If the key sequence is invalid, or an out of bounds value is attempted to be set, the light flashes 5 times for 1 second. (The command then needs to be sent from the start.)

Example key sequence: (Set the intensity level to 5 – undefined.)

I **5** **T/C**

The light flashes 5 times for 1 second.

When a key sequence has been entered successfully the light will respond acknowledgement with a 1 second flash.



Optional GPS Synchronisation

Avlite has utilized the latest advancements in GPS technology to develop an internal synchronisation system that can be incorporated into the lights. Using overhead satellites, multiple obstruction lights set to the same flash pattern will flash in unison.

No additional power supplies, aeriels or control systems are required, and with its microprocessor-based system, the GPS option is specifically designed to provide maximum reliability and performance over a wide range of environmental conditions.

OPERATING PRINCIPLE

Each light operates independently and requires no operator intervention. A minimum of 4 satellites need to be in view for the built-in GPS receiver to collect time data. At dusk, the light sensor will turn the light on. If time data is available the light will come on synchronised to every other light with the same selected flash code.

Synchronisation is achieved using an internal algorithm based on the highly accurate time base and time data received from the satellites. The satellite data is provided from a number of earth stations using atomic clocks as the time base. Continuous self-checking ensures that the light will continue to run in synchronisation.

LIGHT ACTIVATION

At power-up the microprocessor checks that the internal GPS module is programmed correctly and is able to provide valid time base and time data.

Once outside with a clear view of the sky, valid data should become available within 20 minutes.

DAYLIGHT OPERATION

During daylight hours the microprocessor is in idle mode to reduce power consumption. Time data continues to be updated once per second. The microprocessor will automatically exit the idle mode as soon as dark conditions are detected.

DARK OPERATION

When dark conditions are detected the light:

- Checks for valid time data and is turned on after a delay based on the current time and the length of the selected flash code;
- If valid time data is not detected the light will turn on after approximately 10 seconds. This light will not be synchronised.
- If the light turns on unsynchronised it will continually check for valid time data. Once valid data is found the light will automatically synchronise.

Note: Lights will not synchronise if different flash codes are selected.

GPS POWER DEMAND

The GPS synchronisation feature has been designed to function with a very low power demand. Typically the total 24hr current used by the GPS module is 36mAh. This is approximately equivalent to 8 minutes of solar charging.



Optional GSM Monitoring & Control

The Avlite obstruction light is available with GSM Cell-Phone Monitoring, enabling operators to remotely monitor the status of their installation. The system can also be configured to send out SMS text messages or e-mail alerts to designated operators should alarm conditions be triggered, such as low voltage or light failure.

Please contact Avlite for operational information for GSM Monitoring & Control.



Maintenance & Servicing

Designed to be maintenance free the Obstruction Lights requires minimal attention, though the following maintenance and servicing information is provided to help ensure the life of your Avlite product.

- Occasional cleaning of the dome lens may be required using a cloth and warm soapy water.

Trouble Shooting

Problem	Remedy
Light will not activate.	<ul style="list-style-type: none">• Ensure proper connectivity with power supply• Ensure that the power supply has the right polarity and voltage range• Cover the light sensor to force the light ON

Lantern Status

The AV-OL-IMB-12/UM lanterns are fitted with two status LEDs and provide the operator with an indication of the lantern status.

There is one red and one yellow status LED. The red status LED is used to indicate the health of the Lantern's power system. The yellow status LED is used to indicate the operational status of the lantern. These indicator LED's can be viewed at the base of the lens.

Red Status LED	Lantern Status	Lantern	Condition
Steady	Flat Battery cut off is in effect	OFF	Battery voltage is less than 10.0V
Slow	High Voltage	ON	Battery voltage is above 13.5V
Off	Optimal Voltage	ON	Battery Voltage is between 12.5V – 13.5V
1 Quick	OK Voltage	ON	Battery Voltage is between 12.0V – 12.5V
2 Quick	Low Voltage	ON	Battery Voltage is between 11.5V – 12.0V
3 Quick	Poor Voltage	ON	Battery Voltage is between 10.0V – 11.5V
4 Quick	Flat Voltage	ON	Battery voltage is less than 10.0V

Once the Flat Battery cutoff condition is in effect, the lantern will not turn back on until it sees day light and the battery voltage is above 12.5V for at least one minute.

Yellow Status LED	Lantern Status	Lantern	Condition
Off	Daylight, Standby	OFF	Lantern is in Daylight and in Dusk till Dawn mode or in Standby Mode
Quick Flashing 0.15s on, 0.15s off	Day to night transition	OFF	Light is activating and will turn on after detecting 30 seconds of continuous darkness.
2 Quick Flashes every 2s	Night Operation, Not Synchronized	ON	Lantern is in Normal operating condition. It is not connected to any GPS synchronisation
1 Quick Flashes every 2s	Night Operation, Sync in Progress	ON	Lantern is 're-syncing' with GPS. The lantern re-sync's with the GPS every 15 minutes.
Slow Flashing 1.5s on, 1.5s off	Night Operation, Synchronized	ON	Normal operating condition. Lantern is synchronised to GPS-enabled lanterns
2 Quick flashes every 11s	Night Operation, Synchronized	ON	Lantern is a Hard Wire Synchronisation Slave.

If the lantern is not fitted with GPS Synchronisation Option, then the following conditions are not possible: 1 Quick Flash, and Slow Flashing.

The LEDs are located on the side of the lantern.

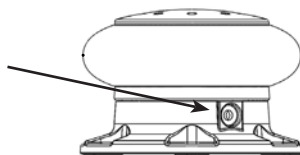



Certification

Certified to: FAA AC NO: 150/5345-43 L-864
FAA Engineering Brief No. 67
DGAC L-864



Avlite Light Warranty V1.2

Activating the Warranty

Upon purchase, the Avlite Systems warranty must be activated for recognition of future claims. To do this you need to register on-line. Please complete the Online Registration Form at:

www.avlite.com

Avlite Systems will repair or replace your lantern in the event of electronic failure for a period of up to three years from the date of purchase.

Avlite Systems will repair or replace any ancillary or accessory products in the event of failure for a period of up to one year from the date of purchase, as per the terms & conditions below.

The unit must be returned to Avlite freight prepaid.

Warranty Terms

1. Avlite Systems warrants that any Avlite aviation products fitted with telemetry equipment including but not limited to AIS, GSM, GPS or RF ("Telemetry Products") will be free from defective materials and workmanship under normal and intended use, subject to the conditions hereinafter set forth, for a period of twelve (12) months from the date of purchase by the original purchaser.
2. Avlite Systems warrants that any rotationally-moulded products ("Roto-Moulded Products") and accessory products ("Accessory Products") will be free from defective materials and workmanship under normal and intended use, subject to the conditions hereinafter set forth, for a period of twelve (12) months from the date of purchase by the original purchaser.
3. Avlite Systems warrants that any Avlite aviation products other than the Telemetry Products, Roto-Moulded Products and Accessory Products ("Avlite Products") will be free from defective materials and workmanship under normal and intended use, subject to the conditions hereinafter set forth, for a period of four (4) years from the date of purchase by the original purchaser.
4. Avlite Systems will repair or replace, at Avlite's sole discretion, any Telemetry Products, Roto-Moulded Products, Accessory Products or Avlite Products found to be defective in material and workmanship in the relevant warranty period so long as the Warranty Conditions (set out below) are satisfied.
5. If any Telemetry Products or Avlite Products are fitted with a rechargeable battery, Avlite Systems warrants the battery will be free from defect for a period of one (1) year when used within original manufacturer's specifications and instructions.

Warranty Conditions

This Warranty is subject to the following conditions and limitations;

1. The warranty is applicable to lanterns manufactured from 1/1/2009.
2. The warranty is void and inapplicable if:
 - a. the product has been used or handled other than in accordance with the instructions in the owner's manual and any other information or instructions provided to the customer by Avlite;
 - b. the product has been deliberately abused, or misused, damaged by accident or neglect or in being transported; or
 - c. the defect is due to the product being repaired or tampered with by anyone other than Avlite or authorised Avlite repair personnel.
3. The customer must give Avlite Systems notice of any defect with the product within 30 days of the customer becoming aware of the defect.
4. Rechargeable batteries have a limited number of charge cycles and may eventually need to be replaced. Typical battery replacement period is 3-4 years. Long term exposure to high temperatures will shorten the battery life. Batteries used or stored in a manner inconsistent with the manufacturer's specifications and instructions shall not be covered by this warranty.
5. No modifications to the original specifications determined by Avlite shall be made without written approval of Avlite Systems.
6. Avlite lights can be fitted with 3rd party power supplies and accessories but are covered by the 3rd



- party warranty terms and conditions.
7. The product must be packed and returned to Avlite Systems by the customer at his or her sole expense. Avlite Systems will pay return freight of its choice. A returned product must be accompanied by a written description of the defect and a photocopy of the original purchase receipt. This receipt must clearly list model and serial number, the date of purchase, the name and address of the purchaser and authorised dealer and the price paid by the purchaser. On receipt of the product, Avlite Systems will assess the product and advise the customer as to whether the claimed defect is covered by this warranty.
 8. Avlite Systems reserves the right to modify the design of any product without obligation to purchasers of previously manufactured products and to change the prices or specifications of any product without notice or obligation to any person.
 9. Input voltage shall not exceed those recommended for the product.
 10. Warranty does not cover damage caused by the incorrect replacement of battery in solar lantern models.
 11. This warranty does not cover any damage or defect caused to any product as a result of water flooding or any other acts of nature.
 12. There are no representations or warranties of any kind by Avlite or any other person who is an agent, employee, or other representative or affiliate of Avlite, express or implied, with respect to condition of performance of any product, their merchantability, or fitness for a particular purpose, or with respect to any other matter relating to any products.

Limitation of Liability

To the extent permitted by acts and regulations applicable in the country of manufacture, the liability of Avlite Systems under this Warranty will be, at the option of Avlite Systems, limited to either the replacement or repair of any defective product covered by this Warranty. Avlite Systems will not be liable to Buyer for consequential damages resulting from any defect or deficiencies in accepted items.

Limited to Original Purchaser

This Warranty is for the sole benefit of the original purchaser of the covered product and shall not extend to any subsequent purchaser of the product.

Miscellaneous

Apart from the specific warranties provided under this warranty, all other express or implied warranties relating to the above product is hereby excluded to the fullest extent allowable under law. The warranty does not extend to any lost profits, loss of good will or any indirect, incidental or consequential costs or damages or losses incurred by the purchaser as a result of any defect with the covered product.

Warrantor

Avlite Systems has authorised distribution in many countries of the world. In each country, the authorised importing distributor has accepted the responsibility for warranty of products sold by distributor. Warranty service should normally be obtained from the importing distributor from whom you purchased your product. In the event of service required beyond the capability of the importer, Avlite Systems will fulfil the conditions of the warranty. Such product must be returned at the owner's expense to the Avlite Systems factory, together with a photocopy of the bill of sale for that product, a detailed description of the problem, and any information necessary for return shipment.

Other Avlite Products Available



Solar Aviation Lighting



Helipad Lighting



Obstruction Lighting



Airfield Markers & Accessories

Typical Applications

- Temporary & permanent airfield lighting
- Remote, emergency & defence airfield lighting
- Barricade, hazard & perimeter lighting
 - Helipad lighting
- Obstruction lighting

For a complete list of product compliances including ICAO & FAA, please contact Avlite today



Portable Airfield Lighting System



Avlite
www.avlite.com

AUSTRALIA
t: +61 (0)3 5977 6128

USA
t: +1 (603) 737 1310

UNITED KINGDOM
t: +44 (0) 1502 588026

