

**Avlite**<sup>®</sup>  
www.avlite.com



**AV-OL Series**  
**Low Intensity Obstruction Light**  
**Complete Light Assembly**  
**Type 1 & Type 2 Power Supplies**  
**Installation & Service Manual**

Version 1.0



## Table of Contents

<b>Introduction</b> .....	Page 4
<b>Technology</b> .....	Page 4
<b>AV-OL Series Low Intensity Obstruction Light Complete Light Assembly</b>	
<b>Type 1 &amp; Type 2 Models</b> .....	Page 5
<b>Unpacking, Mounting, Wiring &amp; Setup</b> .....	Page 10
Unpacking.....	Page 10
Mounting.....	Page 10
Wiring.....	Page 10
Setup .....	Page 11
Battery .....	Page 11
Light Head .....	Page 11
<b>Maintenance &amp; Servicing</b> .....	Page 12
<b>Trouble Shooting</b> .....	Page 13
<b>Appendix</b> .....	Page 14
Wiring Diagram.....	Page 14
Product Order Codes.....	Page 15
<b>Avlite Light Warranty</b> .....	Page 18

Version No.	Description	Date	Approved
1.0	Manual launch	October 2013	S. Turner



## **Introduction**

**Congratulations! By choosing to purchase an Avlite light, you have become the owner of one of the most advanced solar LED obstruction lights in the world.**

Avlite Systems draws on more than 25 years experience in the design and manufacture of navigation aids, and particular care has been taken to ensure your light gives years of trouble free service.

As a commitment to producing the highest quality products for our customers, Avlite has been independently certified as complying with the requirements of ISO 9001:2008 quality management system.

By taking a few moments to browse through this booklet, you will become familiar with the versatility of your light, and be able to maximise its operating function.

Please remember to complete the Avlite warranty registration card accompanying your light.

## **Technology**

***Avlite Systems is a world-class solar lighting systems manufacturer with a proven reputation for rapid, innovative, and agile technology solutions designed specifically for defense, government, civil and humanitarian aid operations in the most remote, toughest environments.***

### **Electronics**

Avlite employs leading in-house electronic engineers in the design and development of software and related circuitry. All individual electronic components are sourced directly by Avlite procurement staff ensuring that only the highest quality components are used in our products.

### **LED Technology**

All Avlite lights use the latest advancements in LED (Light Emitting Diode) technology as a light source. The major advantage of LED's over traditional light sources is well established in that they typically have an operational life in excess of 100,000 hours, resulting in substantial savings to maintenance and servicing costs.

### **Precision Construction**

Commitment to investing in the design and construction of injection-moulded parts including optic lenses, light bases and a range of other components ensures that all Avlite products are of a consistent and superior quality.

### **Optical Performance**

Avlite manufactures a range of aviation LED lenses moulded from multi-cavity dies. The company has superior in-house lens manufacturing capabilities to support outstanding optical performance.

### **Award-winning, Patented Technology**

Several United States and Australian patent registrations are held on Avlite's range of innovative designs, with other regional patents pending in Canada, United Kingdom and Europe.

# AV-OL Series Low Intensity Obstruction Light Complete Light Assembly Type 1 & Type 2 Models

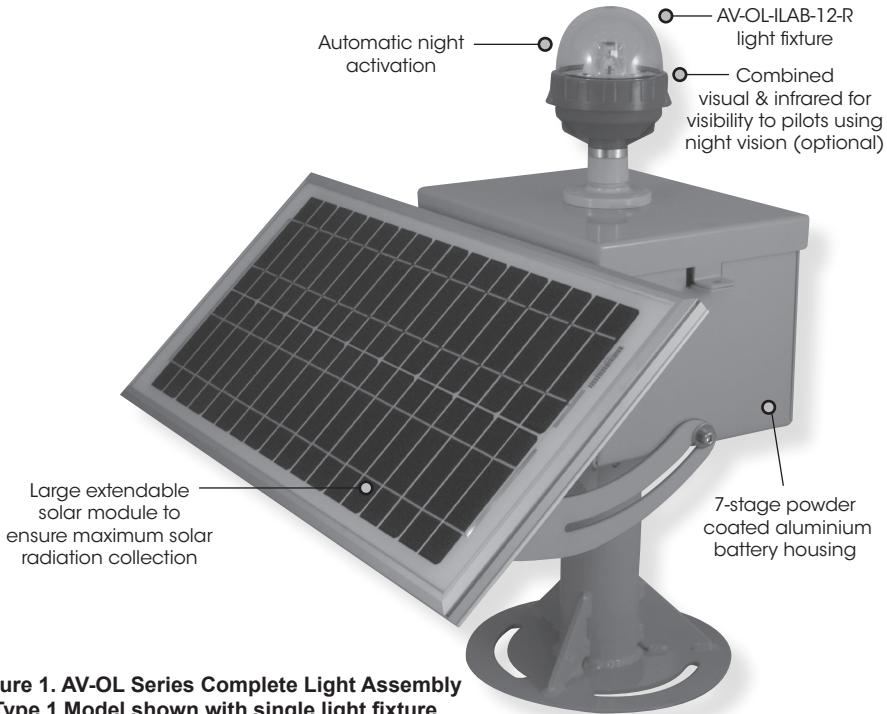
*Avlite's low intensity LED obstruction light complete assembly is a self-contained, solar powered obstruction light designed to comply with FAA L-810 and ICAO LIOL Type A and Type B requirements.*

*The solar assembly is available with AV-OL Series single light fixture or AV-OL Series dual light fixture for redundant failsafe.*

*The solar modules charge the battery during daylight hours, and the light automatically begins operation at dusk once the ambient light threshold drops sufficiently.*

*The assembly is available in two solar/battery configurations to suit a range of installations and ensures years of maintenance-free reliable service.*

*The obstruction light is also available with combined visual and infrared (IR) for visibility to pilots using night vision.*



**Figure 1. AV-OL Series Complete Light Assembly  
Type 1 Model shown with single light fixture**

\* Specifications subject to change or variation without notice  
\* Subject to standard terms and conditions

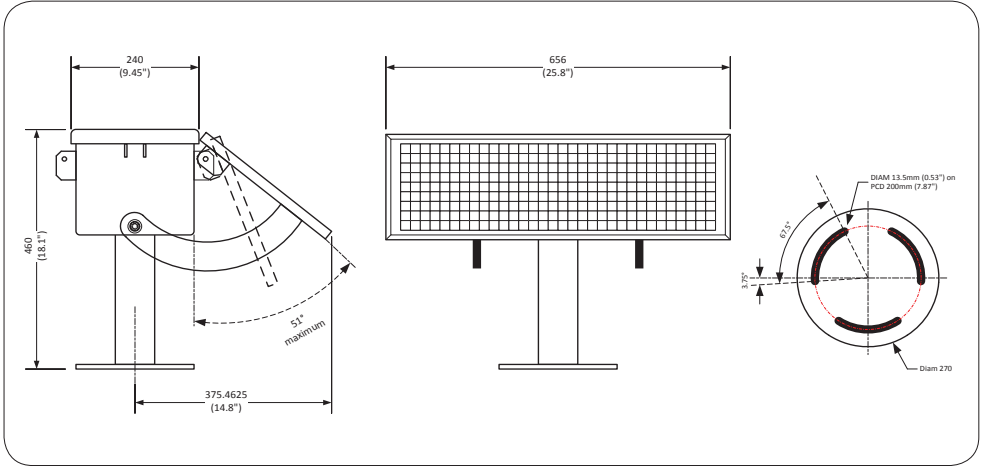


SPECIFICATIONS * *	Type 1 Power Supply	Type 2 Power Supply
<b>Solar Characteristics</b>		
Solar Module Type	Multicrystalline	Multicrystalline
Output (watts)	20	40
Solar Module Efficiency (%)	14	14
Charging Regulation	Microprocessor controlled	Microprocessor controlled
<b>Power Supply</b>		
Battery Type	SLA (Sealed Lead Acid)	SLA (Sealed Lead Acid)
Battery Capacity (Ah)	26	55
Nominal Voltage (V)	12	12
Autonomy (nights)	Steady-on: >10	Steady-on: >20
<b>Physical Characteristics</b>		
Body Material	7-stage powder-coated aluminium	7-stage powder-coated aluminium
Mounting	200mm bolt pattern	200mm bolt pattern
Height (mm/inches)	460 / 18 <sup>1</sup> / <sub>8</sub>	515 / 20 <sup>1</sup> / <sub>4</sub>
Width (mm/inches)	656 / 25 <sup>3</sup> / <sub>4</sub>	665 / 26 <sup>1</sup> / <sub>4</sub>
Mass (kg/lbs)	29.5 / 65	44 / 97
Product Life Expectancy	Up to 12 years	Up to 12 years
<b>Certifications</b>		
CE	EN61000-6-3:1997. EN61000-6-1:1997	EN61000-6-3:1997. EN61000-6-1:1997
Quality Assurance	ISO9001:2008	ISO9001:2008
Waterproof	IP67	IP67
<b>Intellectual Property</b>		
Trademarks	AVLITE® is a registered trademark of Avlite Systems	AVLITE® is a registered trademark of Avlite Systems
<b>Warranty *</b>	3 year warranty	3 year warranty

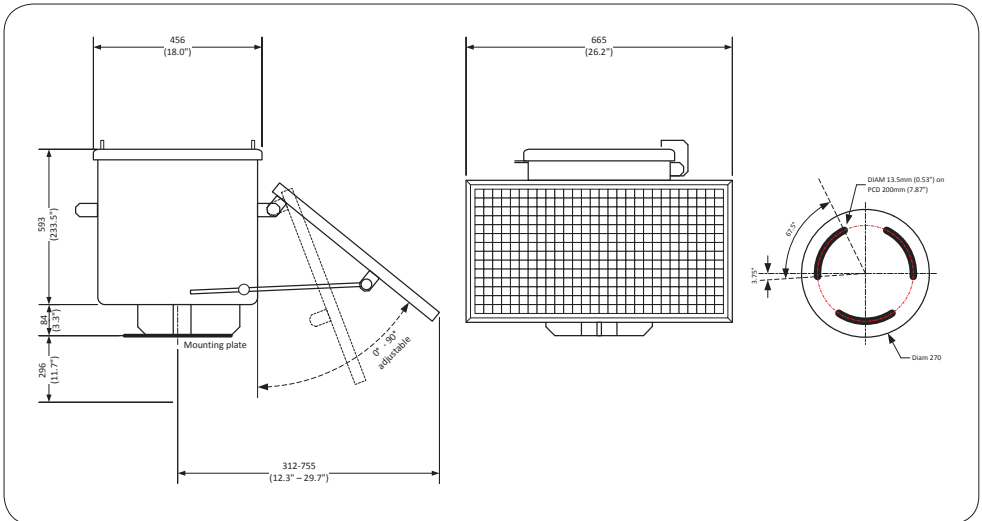
**Important note:**

Type 1 model power supply is not suitable for operating in a ICAO Type B or FAA L-810 dual steady-on configuration. Consult Avlite for solar power supply options.

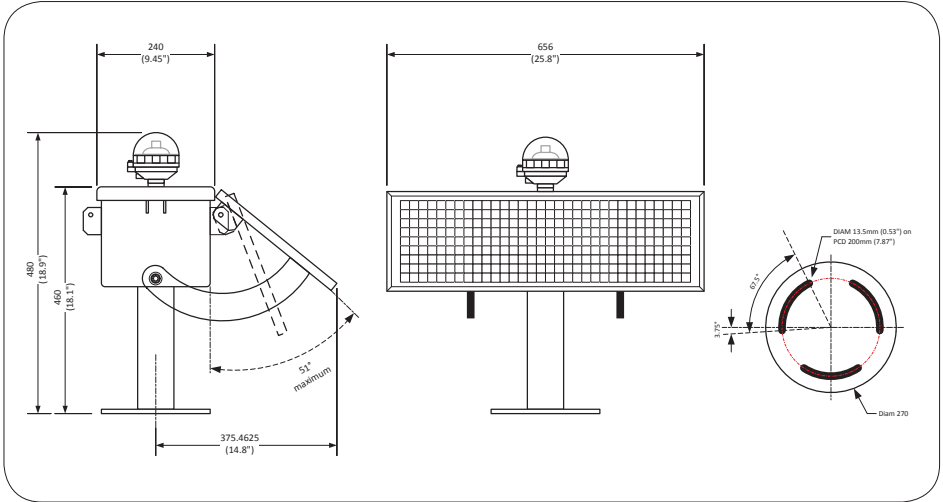
Please contact Avlite for solar calculations to ensure AV-OL Series Type 1 and Type 2 obstruction lights will operate effectively in your country location



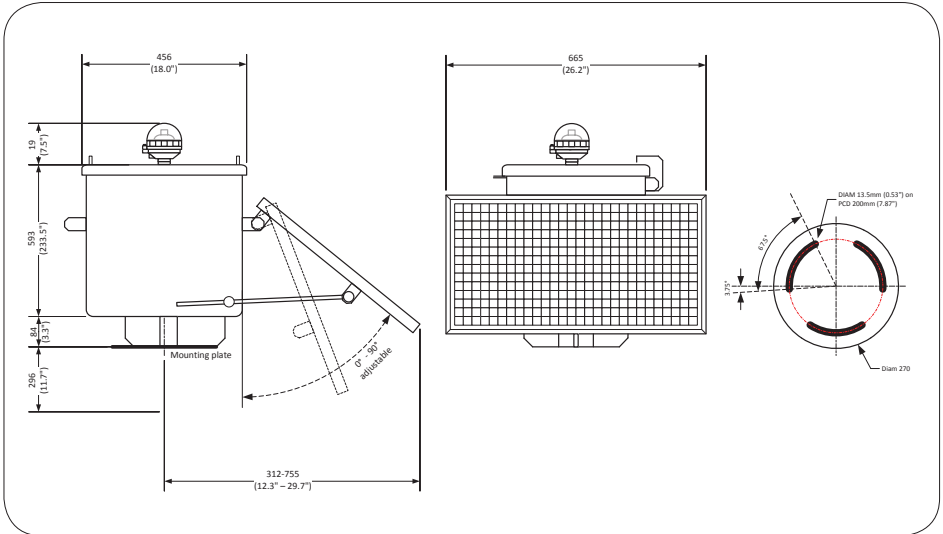
**Figure 2. Type 1 Power Supply**



**Figure 3. Type 2 Power Supply**

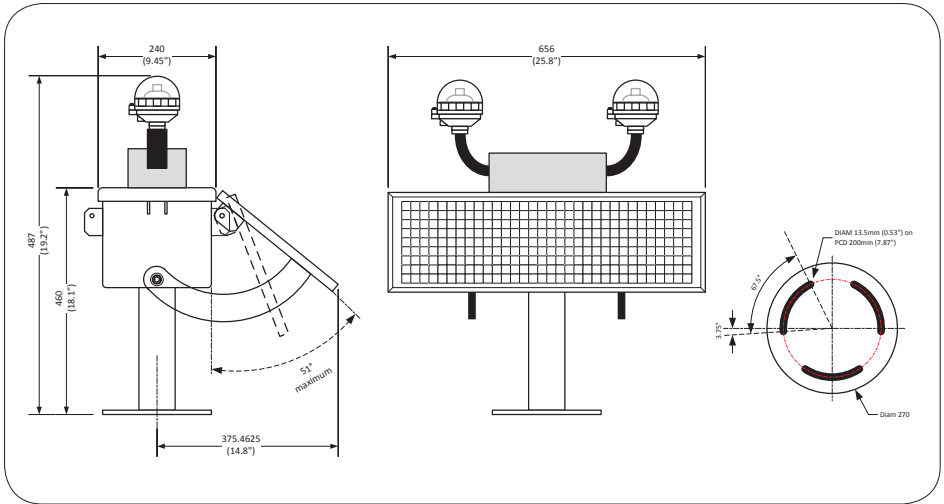


**Figure 4. Type 1 Power Supply with single light fixture**

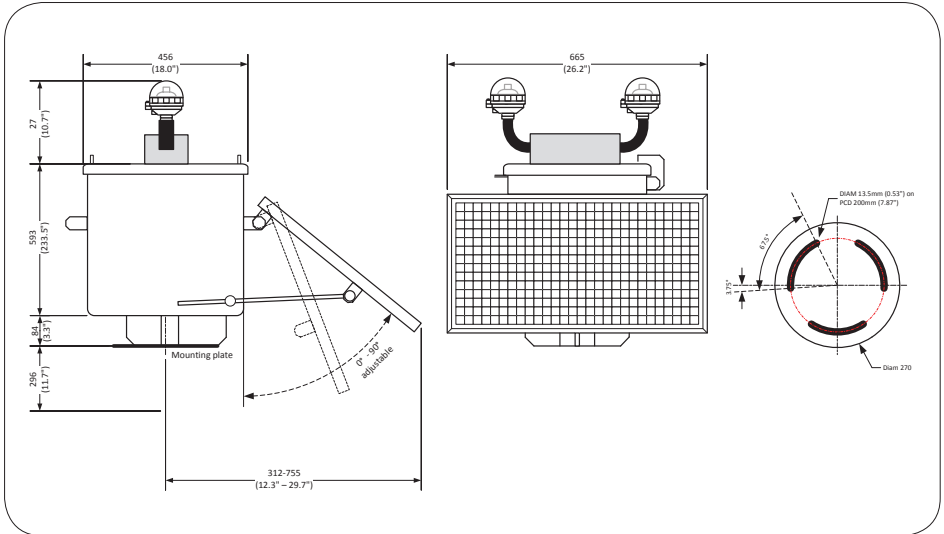


**Figure 5. Type 2 Power Supply with single light fixture**





**Figure 6. Type 1 Power Supply with dual light fixture**



**Figure 7. Type 2 Power Supply with dual light fixture**



# Unpacking, Mounting, Wiring & Setup

## Unpacking

Unpack all hardware and inspect for damage. If there is any damage, please contact your Avlite Office. Retain original packing material for possible future use in shipping.

## Mounting

Mount the complete light on a stable and strong construction/fundament using bolts and nuts. Please consider weight and possible wind load. Use the base as a placing template.

**NOTE:** Make sure the complete light is horizontally levelled and aligned to guarantee the required beam pattern of the obstruction light.

## Wiring

Before proceeding with installation or service, make sure the following conditions are met:

- Install the light in compliance with the effective local electrical code(s)
- To ensure that the light and peripheral equipment function safely and correctly, use cables in compliance with the effective local electrical code.
- Mains power should always be disconnected when work is being done in close proximity to electrical fittings, and electrical work should only be done by a licensed electrician.
- Check the mast lighting circuit is not faulty
- Ensure power lines are not 'live'
- Avoid touching live circuits!
- Ensure the tower or mast is grounded and RF equipment is not operational (NO RF HAZARD)
- Avoid touching any component or any part of the circuitry while the unit is operating. Do not change components or make adjustments inside the unit with power on
- Operate the light only within the indicated electrical ratings and product usage instructions
- Do not stare at the LED or shine the LED into your eyes or those of another person
- Do dispose of the product according to the local laws and regulations for your region, for example, at a recycling center that accepts electronic devices.

**NOTE:** External wiring is not required as the unit is self-containing

**NOTE:** The unit must be installed by a qualified and certified professional.



## **Setup**

### **BATTERY**

- Remove the bolt/lock securing the battery box lid, and open unit
- Inside the battery box is an internal battery container. To access the battery, remove the four screws and lid of this internal container
- Connect the “Battery Negative (-)” wire to the negative terminal of the battery, and the “Battery Positive (+)” wire to the positive terminal of the battery
- Close internal battery container lid making sure no wires are protruding
- Close the metal enclosure lid making sure no wires are protruding
- Secure with bolt/lock. Light is now operational
- To test place dark cover (towel or jacket) on top of light to activate sensor, light will come ON within one minute

### **LIGHT HEAD**

- For single light head setup please refer to AV-OL Series Single Fixture DC Manual, chapter Setup
- For dual light head setup please refer to AV-OL Series Dual Fixture DC Manual, chapter Setup



## Maintenance & Servicing

Designed to be virtually maintenance-free, the solar powered obstruction lights require minimal attention, though the following maintenance and servicing information is provided to help ensure the life of your Avlite product.

1. **Cleaning Lens-** occasional cleaning of the light lens may be required. Using a cloth and warm soapy water, wipe off any foreign matter before rinsing the lens with fresh water.
2. **Cleaning Solar Panels-** occasional cleaning of the solar panels may be required. Using a cloth and warm soapy water, wipe off any foreign matter before rinsing the panels with fresh water.
3. **Battery Check-** inspection of batteries should be performed every three years (minimum) to ensure that the charger, battery and ancillary electronics are functioning correctly. Using a voltage meter, check that the battery voltage is at least 12 volts under 100mA load, and ensure all terminals are clear of foreign matter.

### **REPLACING THE BATTERY**

The solar powered obstruction lights have a sealed battery compartment, which provides the user with the ability to change the battery after years of operation.

- Remove the bolt/lock securing the battery box lid, and open unit
- Inside the battery box is an internal battery container. To access the battery, remove the four screws and lid of this internal container
- Disconnect and remove old battery
- Connect the "Battery Negative (-)" wire to the negative terminal of the new battery, and the "Battery Positive (+)" wire to the positive terminal of the new battery
- Connect the "Battery Positive (+)" and "Battery Negative (-)" wires from the Solar Regulator to the new battery
- Close internal battery container lid making sure no wires are protruding
- Close the battery box lid and secure with bolt/lock. Light is now operational
- To test place dark cover (towel or jacket) on top of light to activate sensor, light will come ON within one minute.

### **NOTE:**

- Care must be taken to observe the polarity of each wire before they are connected.
- To ensure waterproofing of the unit, make sure that no wires are protruding and that there is an even seal.
- Always discard old batteries in a safe manner.



## Trouble Shooting

Problem	Remedy
Light will not activate.	<ul style="list-style-type: none"><li>• Ensure proper connectivity with power supply</li><li>• Ensure that the power supply has the right polarity and voltage range</li><li>• Cover the light sensor to force the light ON</li></ul>

# Appendix

## Wiring Diagram

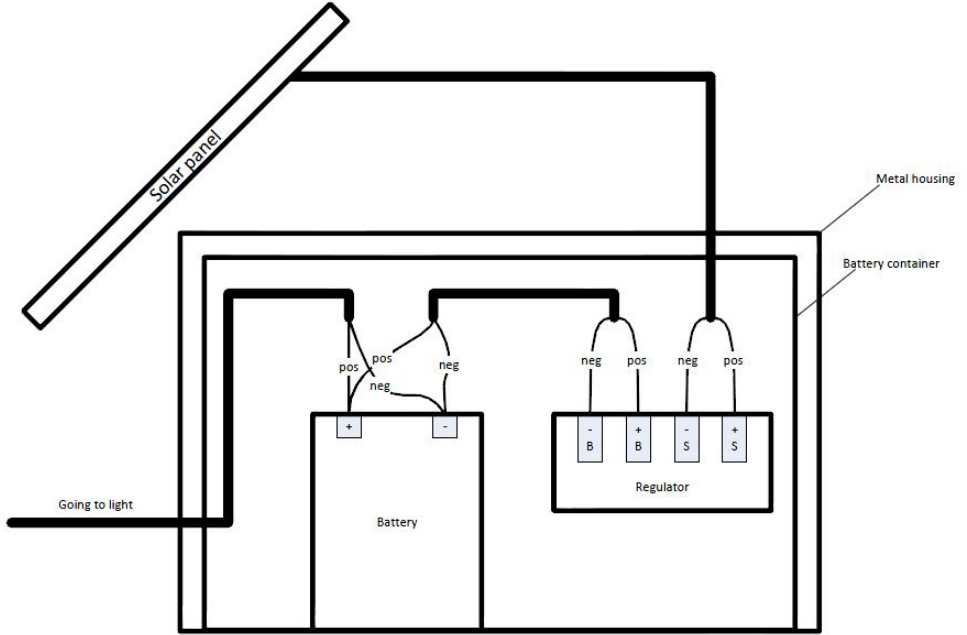


Figure 8. Internal wiring diagram

**Product Order Codes**

**HOW TO ORDER AV-OL Series Obstruction Lights:**

**ICAO Compliant**

**FAA Compliant**

AV-OL-ILAB-[Model]-[Color]-[?]-[?]-[?]-[?]-[?]

AV-OL-FL810-[Model]-[Color]-[?]-[?]-[?]-[?]-[?]

**Product No.:** \_\_\_\_\_

**Product No.:** \_\_\_\_\_

**Model:** \_\_\_\_\_

**Model:** \_\_\_\_\_

12 = 12-48 VDC  
UM = 110-240 VAC

12 = 12-48 VDC  
UM = 110-240 VAC

**Color:** \_\_\_\_\_

**Color:** \_\_\_\_\_

R = Red  
IR = Infrared  
RIR = Combined Red/IR

R = Red  
IR = Infrared  
RIR = Combined Red/IR

**Single or Dual Fixture:** \_\_\_\_\_

**Single or Dual Fixture:** \_\_\_\_\_

[blank] = Single light fixture  
[D] = Dual light fixture

[blank] = Single light fixture  
[D] = Dual light fixture

**Solar/Battery Configuration:** \_\_\_\_\_

**Solar/Battery Configuration:** \_\_\_\_\_

CT1 = Type 1  
CT2 = Type 2  
[blank] = No solar/battery configuration

CT1 = Type 1  
CT2 = Type 2  
[blank] = No solar/battery configuration

**Monitoring & Control:** \_\_\_\_\_

**Monitoring & Control:** \_\_\_\_\_

G = GSM  
RF = Radio Control  
[blank] = No monitoring & control

G = GSM  
RF = Radio Control  
[blank] = No monitoring & control

**RS Communications Port (12-48VDC Model only):** \_\_\_\_\_

**RS Communications Port (12-48VDC Model only):** \_\_\_\_\_

RS = RS communications port  
[blank] = No RS communications port

RS = RS communications port  
[blank] = No RS communications port

**Feature:** \_\_\_\_\_

**Feature:** \_\_\_\_\_

0 = Both lights activated at the same time  
1 = One light activated with automatic changeover ability  
[blank] = No feature

0 = Both lights activated at the same time  
1 = One light activated with automatic changeover ability  
[blank] = No feature



# Notes





# Notes



## **Avlite Light Warranty V1.1**

### **Activating the Warranty**

Upon purchase, the Avlite Systems warranty must be activated for recognition of future claims. To do this you have two (2) options:

1. **Postal Registration**

Please complete the Avlite Systems Warranty Registration Card and return to Avlite within 30 days of your purchase.

2. **Online Registration**

Please complete the Online Registration Form at; [www.avlite.com](http://www.avlite.com)

***Avlite Systems will repair or replace your lantern in the event of electronic failure for a period of up to three years from the date of purchase.***

***The unit must be returned to Avlite freight prepaid.***

### **Warranty Terms**

1. Avlite Systems warrants that any Avlite aviation products fitted with telemetry equipment including but not limited to AIS, GSM, GPS or RF ("Telemetry Products") will be free from defective materials and workmanship under normal and intended use, subject to the conditions hereinafter set forth, for a period of twelve (12) months from the date of purchase by the original purchaser.
2. Avlite Systems warrants that any rotationally-moulded products ("Roto-Moulded Products") and accessory products ("Accessory Products") will be free from defective materials and workmanship under normal and intended use, subject to the conditions hereinafter set forth, for a period of twelve (12) months from the date of purchase by the original purchaser.
3. Avlite Systems warrants that any Avlite aviation products other than the Telemetry Products, Roto-Moulded Products and Accessory Products ("Avlite Products") will be free from defective materials and workmanship under normal and intended use, subject to the conditions hereinafter set forth, for a period of three (3) years from the date of purchase by the original purchaser.
4. Avlite Systems will repair or replace, at Avlite's sole discretion, any Telemetry Products, Roto-Moulded Products, Accessory Products or Avlite Products found to be defective in material and workmanship in the relevant warranty period so long as the Warranty Conditions (set out below) are satisfied.
5. If any Telemetry Products or Avlite Products are fitted with a rechargeable battery, Avlite Systems warrants the battery will be free from defect for a period of one (1) year when used within original manufacturer's specifications and instructions.

### **Warranty Conditions**

This Warranty is subject to the following conditions and limitations;

1. The warranty is applicable to lanterns manufactured from 1/1/2009.
2. The warranty is void and inapplicable if:
  - a. the product has been used or handled other than in accordance with the instructions in the owner's manual and any other information or instructions provided to the customer by Avlite;
  - b. the product has been deliberately abused, or misused, damaged by accident or neglect or in being transported; or
  - c. the defect is due to the product being repaired or tampered with by anyone other than Avlite or authorised Avlite repair personnel.
3. The customer must give Avlite Systems notice of any defect with the product within 30 days of the customer becoming aware of the defect.
4. Rechargeable batteries have a limited number of charge cycles and may eventually need to be replaced. Typical battery replacement period is 3-4 years. Long term exposure to high temperatures will shorten the battery life. Batteries used or stored in a manner inconsistent with the manufacturer's specifications and instructions shall not be covered by this warranty.



5. No modifications to the original specifications determined by Avlite shall be made without written approval of Avlite Systems.
6. Avlite lights can be fitted with 3rd party power supplies and accessories but are covered by the 3rd party warranty terms and conditions.
7. The product must be packed and returned to Avlite Systems by the customer at his or her sole expense. Avlite Systems will pay return freight of its choice. A returned product must be accompanied by a written description of the defect and a photocopy of the original purchase receipt. This receipt must clearly list model and serial number, the date of purchase, the name and address of the purchaser and authorised dealer and the price paid by the purchaser. On receipt of the product, Avlite Systems will assess the product and advise the customer as to whether the claimed defect is covered by this warranty.
8. Avlite Systems reserves the right to modify the design of any product without obligation to purchasers of previously manufactured products and to change the prices or specifications of any product without notice or obligation to any person.
9. Input voltage shall not exceed those recommended for the product.
10. Warranty does not cover damage caused by the incorrect replacement of battery in solar lantern models.
11. This warranty does not cover any damage or defect caused to any product as a result of water flooding or any other acts of nature.
12. There are no representations or warranties of any kind by Avlite or any other person who is an agent, employee, or other representative or affiliate of Avlite, express or implied, with respect to condition of performance of any product, their merchantability, or fitness for a particular purpose, or with respect to any other matter relating to any products.

### **Limitation of Liability**

To the extent permitted by section 68A of the Trade Practices Act 1974 (Cth), the liability of Avlite Systems under this Warranty will be, at the option of Avlite Systems, limited to either the replacement or repair of any defective product covered by this Warranty. Avlite Systems will not be liable to Buyer for consequential damages resulting from any defect or deficiencies in accepted items.

### **Limited to Original Purchaser**

This Warranty is for the sole benefit of the original purchaser of the covered product and shall not extend to any subsequent purchaser of the product.

### **Miscellaneous**

Apart from the specific warranties provided under this warranty, all other express or implied warranties relating to the above product is hereby excluded to the fullest extent allowable under law. The warranty does not extend to any lost profits, loss of good will or any indirect, incidental or consequential costs or damages or losses incurred by the purchaser as a result of any defect with the covered product.

### **Warrantor**

Avlite Systems has authorised distribution in many countries of the world. In each country, the authorised importing distributor has accepted the responsibility for warranty of products sold by distributor. Warranty service should normally be obtained from the importing distributor from whom you purchased your product. In the event of service required beyond the capability of the importer, Avlite Systems will fulfil the conditions of the warranty. Such product must be returned at the owner's expense to the Avlite Systems factory, together with a photocopy of the bill of sale for that product, a detailed description of the problem, and any information necessary for return shipment.

**Other Avlite Products Available**



**Solar Aviation Lighting**



**Helipad Lighting**



**Obstruction Lighting**



**Airfield Markers  
& Accessories**

**Typical Applications**

- Temporary & permanent airfield lighting
- Remote, emergency & defence airfield lighting
- Barricade, hazard & perimeter lighting
  - Helipad lighting
  - Obstruction lighting

For a complete list of product compliances including ICAO & FAA, please contact Avlite today



**Area & Sign Lighting**



**Head Office**

Avlite Systems  
11 Industrial Drive  
Somerville, Vic 3912  
Australia

Tel: +61 (0)3 5977 6128  
Fax: +61 (0)3 5977 6124

Email: info@avlite.com  
Internet: www.avlite.com

A subsidiary of Sealite Pty Ltd www.sealite.com